

# PHILIPPINE ARMY BIDS AND AWARDS COMMITTEE

Fort Andres Bonifacio, Metro Manila

## Procurement of Grenade Launcher, 40mm

**ORD PABAC 027-20**

Lot	Description	Qty (unit)	ABC (Pesos)
1	Grenade Launcher, 40mm	1,024	98,196,992.00

**Bidding Date: December 15, 2020 (Tuesday)  
@ 01:30 P.M.**

**Sixth Edition  
July 2020**

---

# TABLE OF CONTENTS

GLOSSARY OF ACRONYMS, TERMS, AND ABBREVIATIONS .....	3
SECTION I. INVITATION TO BID.....	6
SECTION II. INSTRUCTIONS TO BIDDERS.....	9
SECTION III. BID DATA SHEET .....	16
SECTION IV. GENERAL CONDITIONS OF CONTRACT .....	19
SECTION V. SPECIAL CONDITIONS OF CONTRACT .....	21
SECTION VI. SCHEDULE OF REQUIREMENTS .....	28
SECTION VII. TECHNICAL SPECIFICATIONS .....	29
SECTION VIII. CHECKLIST OF TECHNICAL AND FINANCIAL DOCUMENTS .....	44

---

## **GLOSSARY OF ACRONYMS, TERMS, AND ABBREVIATIONS**

**ABC** – Approved Budget for the Contract.

**BAC** – Bids and Awards Committee.

**Bid** – A signed offer or proposal to undertake a contract submitted by a bidder in response to and in consonance with the requirements of the bidding documents. Also referred to as *Proposal* and *Tender*. (2016 revised IRR, Section 5[c])

**Bidder** – Refers to a contractor, manufacturer, supplier, distributor and/or consultant who submits a bid in response to the requirements of the Bidding Documents. (2016 revised IRR, Section 5[d])

**Bidding Documents** – The documents issued by the Procuring Entity as the bases for bids, furnishing all information necessary for a prospective bidder to prepare a bid for the Goods, Infrastructure Projects, and/or Consulting Services required by the Procuring Entity. (2016 revised IRR, Section 5[e])

**BIR** – Bureau of Internal Revenue.

**BSP** – Bangko Sentral ng Pilipinas.

**Consulting Services** – Refer to services for Infrastructure Projects and other types of projects or activities of the GOP requiring adequate external technical and professional expertise that are beyond the capability and/or capacity of the GOP to undertake such as, but not limited to: (i) advisory and review services; (ii) pre-investment or feasibility studies; (iii) design; (iv) construction supervision; (v) management and related services; and (vi) other technical services or special studies. (2016 revised IRR, Section 5[i])

**CDA** - Cooperative Development Authority.

**Contract** – Refers to the agreement entered into between the Procuring Entity and the Supplier or Manufacturer or Distributor or Service Provider for procurement of Goods and Services; Contractor for Procurement of Infrastructure Projects; or Consultant or Consulting Firm for Procurement of Consulting Services; as the case may be, as recorded in the Contract Form signed by the parties, including all attachments and appendices thereto and all documents incorporated by reference therein.

**CIF** – Cost Insurance and Freight.

**CIP** – Carriage and Insurance Paid.

**CPI** – Consumer Price Index.

**DDP** – Refers to the quoted price of the Goods, which means “delivered duty paid.”

**DTI** – Department of Trade and Industry.

**EXW** – Ex works.

**FCA** – “Free Carrier” shipping point.

**FOB** – “Free on Board” shipping point.

**Foreign-funded Procurement or Foreign-Assisted Project**– Refers to procurement whose funding source is from a foreign government, foreign or international financing institution as specified in the Treaty or International or Executive Agreement. (2016 revised IRR, Section 5[b]).

**Framework Agreement** – Refers to a written agreement between a procuring entity and a supplier or service provider that identifies the terms and conditions, under which specific purchases, otherwise known as “Call-Offs,” are made for the duration of the agreement. It is in the nature of an option contract between the procuring entity and the bidder(s) granting the procuring entity the option to either place an order for any of the goods or services identified in the Framework Agreement List or not buy at all, within a minimum period of one (1) year to a maximum period of three (3) years. (GPPB Resolution No. 27-2019)

**GFI** – Government Financial Institution.

**GOCC** – Government-owned and/or –controlled corporation.

**Goods** – Refer to all items, supplies, materials and general support services, except Consulting Services and Infrastructure Projects, which may be needed in the transaction of public businesses or in the pursuit of any government undertaking, project or activity, whether in the nature of equipment, furniture, stationery, materials for construction, or personal property of any kind, including non-personal or contractual services such as the repair and maintenance of equipment and furniture, as well as trucking, hauling, janitorial, security, and related or analogous services, as well as procurement of materials and supplies provided by the Procuring Entity for such services. The term “related” or “analogous services” shall include, but is not limited to, lease or purchase of office space, media advertisements, health maintenance services, and other services essential to the operation of the Procuring Entity. (2016 revised IRR, Section 5[r])

**GOP** – Government of the Philippines.

**GPPB** – Government Procurement Policy Board.

**INCOTERMS** – International Commercial Terms.

**Infrastructure Projects** – Include the construction, improvement, rehabilitation, demolition, repair, restoration or maintenance of roads and bridges, railways, airports, seaports, communication facilities, civil works components of information technology projects, irrigation, flood control and drainage, water supply, sanitation,

sewerage and solid waste management systems, shore protection, energy/power and electrification facilities, national buildings, school buildings, hospital buildings, and other related construction projects of the government. Also referred to as *civil works or works*. (2016 revised IRR, Section 5[u])

**LGUs** – Local Government Units.

**NFCC** – Net Financial Contracting Capacity.

**NGA** – National Government Agency.

**PhilGEPS** - Philippine Government Electronic Procurement System.

**Procurement Project** – refers to a specific or identified procurement covering goods, infrastructure project or consulting services. A Procurement Project shall be described, detailed, and scheduled in the Project Procurement Management Plan prepared by the agency which shall be consolidated in the procuring entity's Annual Procurement Plan. (GPPB Circular No. 06-2019 dated 17 July 2019)

**PSA** – Philippine Statistics Authority.

**SEC** – Securities and Exchange Commission.

**SLCC** – Single Largest Completed Contract.

**Supplier** – refers to a citizen, or any corporate body or commercial company duly organized and registered under the laws where it is established, habitually established in business and engaged in the manufacture or sale of the merchandise or performance of the general services covered by his bid. (Item 3.8 of GPPB Resolution No. 13-2019, dated 23 May 2019). Supplier as used in these Bidding Documents may likewise refer to a distributor, manufacturer, contractor, or consultant.

**UN** – United Nations.

# SECTION I. INVITATION TO BID

## Procurement of Grenade Launcher, 40mm

### BID REF ORD PABAC 027-20

1. The Philippine Army, through the Advice of Sub-Allotment (ASA) Number 2200-2020-0093 dated 21 February 2020 duly signed by **COL PEDRO C BALISI JR MNSA (CAV) PA**, Chief OAFM, PA intends to apply the following sum being the Approved Budget for the Contract (ABCs) to payments under the contract for each item. Bids received in excess of the ABC for each lot shall be automatically rejected at bid opening.

Lot	Description	Qty (unit)	ABC (Pesos)
1	Grenade Launcher, 40mm	1,024	98,196,992.00

2. The Philippine Army now invite Bids for the above procurement of the **firearm** (herein referred to as GOODS).

Required delivery period and delivery place shall be as follows:

Delivery Period	Delivery Place
Within One Hundred Eighty (180) calendar days after Receipt of Notice to Proceed.	Armament Company, Armament and Ammunition Battalion, Logistics Support Group, Army Support Command, Philippine Army, Camp General Emilio Aguinaldo, Quezon City.

Bidders should have completed within **five (5) years** from the date of Submission and Receipt of Bids a Contract similar to the project.

The description of an eligible bidder is contained in the Bidding Documents, particularly, in Section II (Instructions to Bidders).

3. Bidding will be conducted through open competitive bidding procedures using a non-discretionary “pass/fail” criterion as specified in the 2016 revised Implementing Rules and Regulations (IRR) of Republic Act (RA) No. 9184 otherwise known as the “Government Procurement Reform Act”.

Bidding is open to all interested bidders, whether local or foreign, subject to the conditions for eligibility provided in the 2016 revised IRR of RA No. 9184.

4. Prospective Bidders may obtain further information from PABAC1 Secretariat and inspect the Bidding Documents at the address given below during office hours from 8:00 am to 4:00 pm.

5. The complete set of Bidding Documents may be acquired/purchased by interested Bidders on **November 26, 2020** during office hours (8:00 am - 4:00 pm)

from the given address and websites below in the amount of **Php50,000.00**. The Procuring Entity shall allow the bidder to present its proof of payment for the fees presented in person, by facsimile, or through electronic means.

6. The Philippine Army through PABAC1 will hold a Pre-Bid Conference on the time and date as specified below at the Office of the PABAC1, Fort Andres Bonifacio, Taguig, M.M. and/or through video conferencing or webcasting, which shall be open to prospective bidders.

7. Bids must be duly received by the PABAC1 Secretariat through manual submission at the office address indicated below on or before the date of submission of bids as specified below. Late bids shall not be accepted.

8. All Bids must be accompanied by a bid security in any of the acceptable forms and in the amount stated in ITB Clause 14.

9. Bid opening shall be on the date as specified below and at the given address below through in person (face to face) and/or through video conferencing or webcasting. Bids will be opened in the presence of the bidders' representatives who choose to attend the activity.

The schedule of the bidding activities shall be as follows:

ACTIVITIES	TIME	VENUE
1. Sale and Issuance of Bidding Documents	8:00 am to 4:00 pm only Mondays - Fridays starting Date: <b><u>Nov. 26, 2020</u></b>	Office of the PABAC1, Fort Andres Bonifacio, Taguig, M.M
2. Pre-Bid Conference	Date: <b><u>Dec. 02, 2020 (Wed)</u></b> <b><u>@ 03:00 P.M.</u></b>	<b>BGEN DANILO O CARIÑO PA</b> <b>PABAC1 Chairperson</b> Contact Nr. 845-9555 local 6891 / Fax Nr. 845-9555 local 6893, +63917-648-2806/+63908-932-5241 or at its email address at <a href="mailto:pabacsec@gmail.com">pabacsec@gmail.com</a> .
3. Submission and Opening of Bids	Date and Time: <b><u>Dec. 15, 2020 (Tue)</u></b> @ <b><u>01:30 P.M.</u></b>	

10. The Philippine Army reserves the right to reject any and all bids, declare a failure of bidding, or not award the contract at any time prior to contract award in accordance with Sections 35.6 and 41 of the 2016 revised IRR of RA No. 9184, without thereby incurring any liability to the affected bidder or bidders.

11. For further information, please refer to:

**Office of the PA Bids and Awards Committee 1**  
Fort Andres Bonifacio, Metro Manila

**BGEN DANILO O CARIÑO PA**  
**PABAC1 Chairperson**

Contact Nr. 845-9555 local 6891 / Fax Nr. 845-9555 local 6893, **+63917-648-2806/+63908-932-5241** or at its email address at [pabacsec@gmail.com](mailto:pabacsec@gmail.com).

12. You may visit the following websites:

For downloading of Bidding Documents: **(philgeps.gov.ph and army.mil.ph)**

*Date of Issue:* \_\_\_\_\_

**DANILO O CARIÑO**  
BGEN PA  
PABAC1 Chairperson



## SECTION II. INSTRUCTION TO BIDDERS

### 1. Scope of Bid

The Procuring Entity, **Philippine Army** wishes to receive Bids for the **Procurement of Grenade Launcher, 40mm** under **ORD PABAC 027-20**.

The Procurement Project (referred to herein as "Project") is composed of **one lot**, the details of which are described in Section VII (Technical Specifications).

### 2. Funding Information

2.1. The GOP through the source of funding as indicated below for **2020** in the amount of **Ninety-Eight Million One Hundred Ninety-Six Thousand Nine Hundred Ninety-Two Pesos (PhP98,196,992.00)**.

2.2. The source of funding is **The General Appropriations Act**.

### 3. Bidding Requirements

The Bidding for the Project shall be governed by all the provisions of RA No. 9184 and its 2016 revised IRR, including its Generic Procurement Manuals and associated policies, rules and regulations as the primary source thereof, while the herein clauses shall serve as the secondary source thereof.

Any amendments made to the IRR and other GPPB issuances shall be applicable only to the ongoing posting, advertisement, or **IB** by the BAC through the issuance of a supplemental or bid bulletin.

The Bidder, by the act of submitting its Bid, shall be deemed to have verified and accepted the general requirements of this Project, including other factors that may affect the cost, duration and execution or implementation of the contract, project, or work and examine all instructions, forms, terms, and project requirements in the Bidding Documents.

### 4. Corrupt, Fraudulent, Collusive, and Coercive Practices

The Procuring Entity, as well as the Bidders and Suppliers, shall observe the highest standard of ethics during the procurement and execution of the contract. They or through an agent shall not engage in corrupt, fraudulent, collusive, coercive, and obstructive practices defined under Annex "I" of the 2016 revised IRR of RA No. 9184 or other integrity violations in competing for the Project.

### 5. Eligible Bidders

5.1. Only Bids of Bidders found to be legally, technically, and financially capable will be evaluated.

- 5.2. Foreign ownership exceeding those allowed under the rules may participate pursuant to:
- i. When a Treaty or International or Executive Agreement as provided in Section 4 of the RA No. 9184 and its 2016 revised IRR allow foreign bidders to participate;
  - ii. Citizens, corporations, or associations of a country, included in the list issued by the GPPB, the laws or regulations of which grant reciprocal rights or privileges to citizens, corporations, or associations of the Philippines;
  - iii. When the Goods sought to be procured are not available from local suppliers; or
  - iv. When there is a need to prevent situations that defeat competition or restrain trade.
- 5.3. Pursuant to Section 23.4.1.3 of the 2016 revised IRR of RA No.9184, the Bidder shall have an SLCC that is at least one (1) contract similar to the Project the value of which, adjusted to current prices using the PSA's CPI, must be at least equivalent to:
- a. For the procurement of Non-Expendable Supplies: The Bidder must have completed a single contract that is similar to this Project, equivalent to **at least fifty percent (50%)** of the ABC.
  - b. For procurement where the Procuring Entity has determined, after the conduct of market research, that imposition of (a) will likely result to failure of bidding that will defeat the purpose of public bidding: The Bidder should comply with the following requirements:
    - i. Completed **at least two (2) similar contracts**, the aggregate amount of which should be equivalent to **at least fifty percent (50%)** in the case of non-expendable supplies of the ABC for this Project; and
    - ii. The largest of these similar contracts must be equivalent to **at least half of the percentage** of the ABC as required above.
- 5.4. The Bidders shall comply with the eligibility criteria under Section 23.4.1 of the 2016 IRR of RA No. 9184.

## 6. Origin of Goods

There is no restriction on the origin of goods other than those prohibited by a decision of the UN Security Council taken under Chapter VII of the Charter of the UN, subject to Domestic Preference requirements under **ITB** Clause 18.

## 7. Subcontracts

7.1. The Bidder may subcontract portions of the Project to the extent allowed by the Procuring Entity as stated herein, but in no case more than twenty percent (20%) of the Project.

However, the Procuring Entity has prescribed that Subcontracting is not allowed.

## 8. Pre-Bid Conference

The Procuring Entity will hold a pre-bid conference for this Project on the specified date and time and either at its physical address indicated herein and/or through videoconferencing/webcasting as indicated in paragraph 6 of the **IB**.

## 9. Clarification and Amendment of Bidding Documents

Prospective bidders may request for clarification on and/or interpretation of any part of the Bidding Documents. Such requests must be in writing and received by the Procuring Entity, either at its given address or through electronic mail indicated in the **IB**, at least ten (10) calendar days before the deadline set for the submission and receipt of Bids.

## 10. Documents comprising the Bid: Eligibility and Technical Components

10.1. The first envelope shall contain the eligibility and technical documents of the Bid as specified in **Section VIII (Checklist of Technical and Financial Documents)**.

10.2. The Bidder's SLCC as indicated in **ITB** Clause 5.3 should have been completed within the last five (5) years prior to the deadline for the submission and receipt of bids.

10.3. If the eligibility requirements or statements, the bids, and all other documents for submission to the BAC are in foreign language other than English, it must be accompanied by a translation in English, which shall be authenticated by the appropriate Philippine foreign service establishment, post, or the equivalent office having jurisdiction over the foreign bidder's affairs in the Philippines. Similar to the required authentication above, for Contracting Parties to the Apostille Convention, only the translated documents shall be authenticated through an apostille pursuant to GPPB Resolution No. 13-2019 dated 23 May 2019. The English translation shall govern, for purposes of interpretation of the bid.

## 11. Documents comprising the Bid: Financial Component

11.1. The second bid envelope shall contain the financial documents for the Bid as specified in **Section VIII (Checklist of Technical and Financial Documents)**.

- 11.2. If the Bidder claims preference as a Domestic Bidder or Domestic Entity, a certification issued by DTI shall be provided by the Bidder in accordance with Section 43.1.3 of the 2016 revised IRR of RA No. 9184.
- 11.3. Any bid exceeding the ABC indicated in paragraph 1 of the **IB** shall not be accepted.
- 11.4. For Foreign-funded Procurement, a ceiling may be applied to bid prices provided the conditions are met under Section 31.2 of the 2016 revised IRR of RA No. 9184.

## 12. Bid Prices

- 12.1. Prices indicated on the Price Schedule shall be entered separately in the following manner:
  - a. For Goods offered from within the Procuring Entity's country:
    - i. The price of the Goods quoted EXW (ex-works, ex-factory, ex-warehouse, ex-showroom, or off-the-shelf, as applicable);
    - ii. The cost of all customs duties and sales and other taxes already paid or payable;
    - iii. The cost of transportation, insurance, and other costs incidental to delivery of the Goods to their final destination; and
    - iv. The price of other (incidental) services, if any, listed in e.
  - b. For Goods offered from abroad:
    - i. Unless otherwise stated in the **BDS**, the price of the Goods shall be quoted delivered duty paid (DDP) with the place of destination in the Philippines as specified in the **BDS**. In quoting the price, the Bidder shall be free to use transportation through carriers registered in any eligible country. Similarly, the Bidder may obtain insurance services from any eligible source country.
    - ii. The price of other (incidental) services, if any, as listed in **Section VII (Technical Specifications)**.

## 13. Bid and Payment Currencies

- 13.1. For Goods that the Bidder will supply from outside the Philippines, the bid prices may be quoted in the local currency or tradeable currency accepted by the BSP at the discretion of the Bidder. However, for

purposes of bid evaluation, Bids denominated in foreign currencies, shall be converted to Philippine currency based on the exchange rate as published in the BSP reference rate bulletin on the day of the bid opening.

13.2. Payment of the contract price shall be made in **Philippine Pesos**.

#### **14. Bid Security**

14.1. The Bidder shall submit a Bid Securing Declaration or any form of Bid Security in the amount indicated in the **BDS**, which shall be not less than the percentage of the ABC in accordance with the schedule in the **BDS**.

14.2. The Bid and bid security shall be valid until **one hundred twenty (120) calendar days from the date of opening of bids**. Any Bid not accompanied by an acceptable bid security shall be rejected by the Procuring Entity as non-responsive.

#### **15. Sealing and Marking of Bids**

Each Bidder shall submit one copy of the first and second components of its Bid.

The Procuring Entity may request additional hard copies and/or electronic copies of the Bid. However, failure of the Bidders to comply with the said request shall not be a ground for disqualification.

If the Procuring Entity allows the submission of bids through online submission or any other electronic means, the Bidder shall submit an electronic copy of its Bid, which must be digitally signed. An electronic copy that cannot be opened or is corrupted shall be considered non-responsive and, thus, automatically disqualified.

#### **16. Deadline for Submission of Bids**

16.1. The Bidders shall submit on the specified date and time and either at its physical address or through online submission as indicated in paragraph 7 of the **IB**.

#### **17. Opening and Preliminary Examination of Bids**

17.1. The BAC shall open the Bids in public at the time, on the date, and at the place specified in paragraph 9 of the **IB**. The Bidders' representatives who are present shall sign a register evidencing their attendance. In case videoconferencing, webcasting or other similar technologies will be used, attendance of participants shall likewise be recorded by the BAC Secretariat.

In case the Bids cannot be opened as scheduled due to justifiable reasons, the rescheduling requirements under Section 29 of the 2016 revised IRR of RA No. 9184 shall prevail.

- 17.2. The preliminary examination of bids shall be governed by Section 30 of the 2016 revised IRR of RA No. 9184.

## 18. Domestic Preference

- 18.1. The Procuring Entity will grant a margin of preference for the purpose of comparison of Bids in accordance with Section 43.1.2 of the 2016 revised IRR of RA No. 9184.

## 19. Detailed Evaluation and Comparison of Bids

- 19.1. The Procuring BAC shall immediately conduct a detailed evaluation of all Bids rated “*passed*,” using non-discretionary pass/fail criteria. The BAC shall consider the conditions in the evaluation of Bids under Section 32.2 of the 2016 revised IRR of RA No. 9184.
- 19.2. If the Project allows partial bids, bidders may submit a proposal on any of the lots or items, and evaluation will be undertaken on a per lot or item basis, as the case maybe. In this case, the Bid Security as required by **ITB** Clause 15 shall be submitted for each lot or item separately.
- 19.3. The descriptions of the lots or items shall be indicated in **Section VII (Technical Specifications)**, although the ABCs of these lots or items are indicated in the **BDS** for purposes of the NFCC computation pursuant to Section 23.4.2.6 of the 2016 revised IRR of RA No. 9184. The NFCC must be sufficient for the total of the ABCs for all the lots or items participated in by the prospective Bidder.
- 19.4. The Project shall be awarded as **one contract**.
- 19.5. Except for bidders submitting a committed Line of Credit from a Universal or Commercial Bank in lieu of its NFCC computation, all Bids must include the NFCC computation pursuant to Section 23.4.1.4 of the 2016 revised IRR of RA No. 9184, which must be sufficient for the total of the ABCs for all the lots or items participated in by the prospective Bidder. For bidders submitting the committed Line of Credit, it must be at least equal to ten percent (10%) of the ABCs for all the lots or items participated in by the prospective Bidder.

## 20. Post-Qualification

- 20.1. Within a non-extendible period of five (5) calendar days from receipt by the Bidder of the notice from the BAC that it submitted the Lowest Calculated Bid, the Bidder shall submit its latest income and business tax returns filed and paid through the BIR Electronic Filing and

Payment System (eFPS) and other appropriate licenses and permits required by law and stated in the **BDS**.

## **21. Signing of the Contract**

- 21.1. The documents required in Section 37.2 of the 2016 revised IRR of RA No. 9184 shall form part of the Contract. Additional Contract documents are indicated in the **BDS**.

# Section III. Bid Data Sheet

<b>ITB Clause</b>									
5.2	Foreign Bidders must be duly represented by an <b>authorized local representative.</b>								
5.3	<b>For this purpose, contracts similar to the Project</b> shall mean <b>“Supply and Delivery of Firearms”</b> which must be completed within five (5) years prior to the deadline of the submission and receipt of bids.								
7.1	<b>Subcontracting is not allowed.</b>								
12	The price of the Goods shall be quoted <b>Delivered-Duty-Paid</b> to be delivered at: <b>Armament Company, Armament and Ammunition Battalion, Logistics Support Group, Army Support Command, Philippine Army, Camp General Emilio Aguinaldo, Quezon City.</b>								
14.1	<p>The bid security shall be in the form of a Bid Securing Declaration, or any of the following forms and amounts:</p> <p>a. The amount of not less than <b>One Million Nine Hundred Sixty-Three Thousand Nine Hundred Thirty-Nine Pesos and Eighty-Four Centavos (PhP1,963,939.84)</b> which is equivalent to two percent (2%) of ABC, if bid security is in cash, cashier's/manager's check, bank draft/guarantee or irrevocable letter of credit; <b>or</b></p> <p>b. The amount of not less than <b>Four Million Nine Hundred Nine Thousand Eight Hundred Forty-Nine Pesos and Sixty Centavos (PhP4,909,849.60)</b> which is equivalent to five percent (5%) of ABC, if bid security is in Surety Bond.</p>								
15	Each Bidder shall submit <b>One (1) original copy</b> and <b>two (2) photo copies</b> of the first and second components of its bid. Each components of the bid must be sealed in two (2) separate envelopes duly labeled. Likewise, the two (2) separate envelopes shall be sealed in one (1) big envelope or carton box duly labeled.								
19.3	<p>The Project shall be awarded as <b>one contract.</b></p> <table border="1" style="width: 100%; border-collapse: collapse; margin-top: 10px;"> <thead> <tr> <th style="width: 10%;">Lot</th> <th style="width: 40%;">Description</th> <th style="width: 20%;">Qty (unit)</th> <th style="width: 30%;">ABC (Pesos)</th> </tr> </thead> <tbody> <tr> <td style="text-align: center;">1</td> <td>Grenade Launcher, 40mm</td> <td style="text-align: center;">1,024</td> <td style="text-align: right;">98,196,992.00</td> </tr> </tbody> </table>	Lot	Description	Qty (unit)	ABC (Pesos)	1	Grenade Launcher, 40mm	1,024	98,196,992.00
Lot	Description	Qty (unit)	ABC (Pesos)						
1	Grenade Launcher, 40mm	1,024	98,196,992.00						
20.2	<p>Within a non-extendible period of five (5) calendar days from receipt by the bidder of the notice from the BAC that it submitted the Lowest Calculated Bid, the Bidder shall submit the following:</p> <p style="text-align: center;"><b>Post-Qualification Requirements</b></p> <p><b>For Local Manufacturer/Local Representative of Foreign Manufacturer</b></p> <p>a. <b><u>Submit Certified True Copy</u></b></p> <p style="padding-left: 20px;">a.1 <b>Valid and Current PHILGEPS</b> Certificate of Registration and Membership (Platinum Registration);</p>								



- a.2 **PO's or Contracts** for all Ongoing Contracts as listed per submitted Annex 1;
- a.3 **PO's or Contracts** relative to Single Largest Completed Contract per submitted Annex 2;
- a.4 **End-User's Acceptance**, Official Receipt (duplicate or triplicate copy) or Sales Invoice with Collection Receipt (duplicate or triplicate copy) relative to the Single Largest Completed Contract per submitted Annex 2;
- a.5 **Certificate of Notarial Commission or Appointment** of the Lawyer who notarized the submitted documents;
- a.6 **Indent License**;
- a.7 **ISO Certificate**.

**b. Submit Certified True Copy**

- b.1 **Latest income and business tax returns** manually filed Tax Returns or filed and paid through the BIR Electronic Filing and Payment System (eFPS). The latest income and business tax returns are those within the last six (6) months preceding the date of bid submission;
- b.2 **Registration Certificate** from the Securities and Exchange Commission (SEC), Department of Trade and Industry (DTI) for sole proprietorship, or CDA for cooperatives;
- b.3 **Mayor's/Business permit** issued by the local government where the principal place of business of the bidder is located;
- b.4 **Audited Financial Statements** showing, among others, the prospective bidder's total and current assets and liabilities stamped "received" by the Bureau of Internal Revenue or its duly accredited and authorized institutions, for the preceding calendar year which should not be earlier than two years from the date of bid submission.

**c. Submit Certified True Copy**

- c.1 **Company Profile** (Organization, Affiliated Companies, Production Capability);
- c.2 **Vicinity map/location** of the business;
- c.3 **Certificate that the Bidder is not Blacklisted** issued by **HAFPPS** (TWG shall coordinate to PITC and other procuring agency for the said Certificate during the Post Qualification);  
Note 1: In case of JV, each JV Partner must submit the same Certificate.
- c.4 **Certificate of Employment** of company official/s designated in Indent License (License to Operate).

**For Foreign Manufacturer:**

**Equivalent to the above document issued by country or place of business in English.** If not in English, it must be accompanied by a translation in English, which shall be authenticated by the appropriate Philippine foreign service establishment, post, or the equivalent office having jurisdiction over the foreign bidder's affairs in the Philippines. Similar to the required authentication above, for Contracting Parties to the Apostille Convention, only the translated documents shall be authenticated through an apostille pursuant to

---

---

	<p>GPPB Resolution No. 13-2019 dated 23 May 2019. The English translation shall govern, for purposes of interpretation of the bid; and</p> <p><i><b>In case of Joint Venture, both partners must present/submit above documents.</b></i></p>
--	--

## Section IV. General Conditions of Contract

### 1. Scope of Contract

This Contract shall include all such items, although not specifically mentioned, that can be reasonably inferred as being required for its completion as if such items were expressly mentioned herein. All the provisions of RA No. 9184 and its 2016 revised IRR, including the Generic Procurement Manual, and associated issuances, constitute the primary source for the terms and conditions of the Contract, and thus, applicable in contract implementation. Herein clauses shall serve as the secondary source for the terms and conditions of the Contract.

This is without prejudice to Sections 74.1 and 74.2 of the 2016 revised IRR of RA No. 9184 allowing the GPPB to amend the IRR, which shall be applied to all procurement activities, the advertisement, posting, or invitation of which were issued after the effectivity of the said amendment.

Additional requirements for the completion of this Contract shall be provided in the **Special Conditions of Contract (SCC)**.

### 2. Advance Payment and Terms of Payment

- 2.1. Advance payment of the contract amount is provided under Annex "D" of the revised 2016 IRR of RA No. 9184.
- 2.2. The Procuring Entity is allowed to determine the terms of payment on the partial or staggered delivery of the Goods procured, provided such partial payment shall correspond to the value of the goods delivered and accepted in accordance with prevailing accounting and auditing rules and regulations. The terms of payment are indicated in the **SCC**.

### 3. Performance Security

Within ten (10) calendar days from receipt of the Notice of Award by the Bidder from the Procuring Entity but in no case later than prior to the signing of the Contract by both parties, the successful Bidder shall furnish the performance security in any of the forms prescribed in Section 39 of the 2016 revised IRR of RA No. 9184.

### 4. Inspection and Tests

The Procuring Entity or its representative shall have the right to inspect and/or to test the Goods to confirm their conformity to the Project specifications at no extra cost to the Procuring Entity in accordance with the Generic Procurement Manual. In addition to tests in the **SCC, Section IV (Technical Specifications)** shall specify what inspections and/or tests the Procuring

Entity requires, and where they are to be conducted. The Procuring Entity shall notify the Supplier in writing, in a timely manner, of the identity of any representatives retained for these purposes.

All reasonable facilities and assistance for the inspection and testing of Goods, including access to drawings and production data, shall be provided by the Supplier to the authorized inspectors at no charge to the Procuring Entity.

## **5. Warranty**

- 5.1 In order to assure that manufacturing defects shall be corrected by the Supplier, a warranty shall be required from the Supplier as provided under Section 62.1 of the 2016 revised IRR of RA No. 9184.
- 5.2 The Procuring Entity shall promptly notify the Supplier in writing of any claims arising under this warranty. Upon receipt of such notice, the Supplier shall, repair or replace the defective Goods or parts thereof without cost to the Procuring Entity, pursuant to the Generic Procurement Manual.

## **6. Liability of the Supplier**

The Supplier's liability under this Contract shall be as provided by the laws of the Republic of the Philippines.

If the Supplier is a joint venture, all partners to the joint venture shall be jointly and severally liable to the Procuring Entity.

**SECTION V. SPECIAL CONDITIONS OF CONTRACT**

**Special Conditions of Contract**

<b>SPECIAL CONDITIONS OF CONTRACT</b>	
<b>GCC Clause</b>	
	<p><b>Delivery and Documents –</b></p> <p>For purposes of the Contract, “EXW,” “FOB,” “FCA,” “CIF,” “CIP,” “DDP” and other trade terms used to describe the obligations of the parties shall have the meanings assigned to them by the current edition of INCOTERMS published by the International Chamber of Commerce, Paris. The Delivery terms of this Contract shall be as follows:</p> <p><b><i>For Goods Supplied from Abroad:</i></b>                      The delivery terms applicable to the Contract are “<b>Delivered-Duty-Paid (DDP) Delivered at Armament Company, Armament and Ammunition Battalion, Logistics Support Group, Army Support Command, Philippine Army, Camp General Emilio Aguinaldo, Quezon City, Philippines.</b> In accordance with INCOTERMS.”</p> <p><b><i>For Goods Supplied from Within the Philippines:</i></b>                      “The delivery terms applicable to this Contract is “<b>delivered Armament Company, Armament and Ammunition Battalion, Logistics Support Group, Army Support Command, Philippine Army, Camp General Emilio Aguinaldo, Quezon City, Philippines</b>”. Risk and title will pass from the Supplier to the Procuring Entity upon receipt and final acceptance of the Goods at their final destination.”</p> <p>Delivery of the Goods shall be made by the Supplier in accordance with the terms specified in <b>Section VI. Schedule of Requirements. Deliveries for “safekeeping” are allowed.</b> However, the Procuring Entity is not liable of any damage/s that may be incurred while the goods are on safekeep.</p> <p>The details of shipping and/or other documents to be furnished by the Supplier are as follows:</p> <p><b><i>For Goods supplied from within the Philippines:</i></b>                      Upon delivery of the Goods to the Project Site, the Supplier shall notify the Procuring Entity and present the following documents to the Procuring Entity:</p> <ul style="list-style-type: none"> <li>(i) Original and four copies delivery receipt/note, railway receipt, or truck receipt;</li> <li>(ii) Original Supplier’s factory inspection report;</li> <li>(iii) Original and four copies of the Manufacturer’s and/or Supplier’s warranty certificate;</li> </ul>

- (iv) Original and four copies of the certificate of origin (for imported Goods);
- (v) Delivery receipt detailing number and description of items received signed by the authorized receiving personnel; and
- (vi) Certificate of Acceptance/Inspection Report signed by the Procuring Entity's representative at the Project Site.

***For Goods supplied from abroad:***

Upon shipment, the Supplier shall notify the Procuring Entity and the insurance company by cable the full details of the shipment, including Contract Number, description of the Goods, quantity, vessel, bill of lading number and date, port of loading, date of shipment, port of discharge etc. Upon delivery to the Project Site, the Supplier shall notify the Procuring Entity and present the following documents as applicable with the documentary requirements of any letter of credit issued taking precedence:

- (i) Original and four copies of the Supplier's invoice showing Goods' description, quantity, unit price, and total amount;
- (ii) Original and four copies of the negotiable, clean shipped on-board bill of lading marked "freight pre-paid" and five copies of the non-negotiable bill of lading;
- (iii) Original Supplier's factory inspection report;
- (iv) Original and four copies of the Manufacturer's and/or Supplier's warranty certificate;
- (v) Original and four copies of the certificate of origin (for imported Goods);
- (vi) Delivery receipt detailing number and description of items received signed by the Procuring Entity's representative at the Project Site; and
- (vii) Certificate of Acceptance/Inspection Report signed by the Procuring Entity's representative at the Project Site.

**For purposes of this Clause the Procuring Entity's Representative at the Project Site is: PA TIAC, APAO, OAFM.**

**Incidental Services –**

The Supplier is required to provide all of the following services, including additional services, if any, specified in Section VI. Schedule of Requirements:

- furnishing of a detailed operations and maintenance manual for each appropriate unit of the supplied Goods;
- The Contract price for the Goods shall include the prices charged by the Supplier for incidental services and shall not exceed the prevailing rates charged to other parties by the Supplier for similar services.

**Packaging – (Annex 4-C)**

The Supplier shall provide such packaging of the Goods as is required to prevent their damage or deterioration during transit to their final destination, as indicated in this Contract. The packaging shall be sufficient to withstand, without limitation, rough handling during transit and exposure to extreme temperatures, salt and precipitation during transit, and open storage. Packaging case size and weights shall take into consideration, where appropriate, the remoteness of the GOODS' final destination and the absence of heavy handling facilities at all points in transit.

The packaging, marking, and documentation within and outside the packages shall comply strictly with such special requirements as shall be expressly provided for in the Contract, including additional requirements, if any, specified below, and in any subsequent instructions ordered by the Procuring Entity.

The outer packaging must be clearly marked on at least four (4) sides as follows:

- Name of the Procuring Entity
- Name of the Supplier
- Contract Description
- Final Destination
- Gross weight
- Any special lifting instructions
- Any special handling instructions
- Any relevant HAZCHEM classifications

A packaging list identifying the contents and quantities of the package is to be placed on an accessible point of the outer packaging if practical. If not practical the packaging list is to be placed inside the outer packaging but outside the secondary packaging.

The Supplier shall provide such packaging of the Goods as is required to prevent their damage or deterioration during transit to their final destination, as indicated in this Contract. The packaging shall be sufficient to withstand, without limitation, rough handling during transit and exposure to extreme temperatures, salt and precipitation during transit, and open storage. Packaging case size and weights shall take into consideration, where appropriate, the remoteness of the GOODS' final destination and the absence of heavy handling facilities at all points in transit.

The packaging, marking, and documentation shall be in accordance with the manufacturer's standard.

**Insurance –**

The Goods supplied under this Contract shall be fully insured by the Supplier in a freely convertible currency against loss or damage incidental to manufacture or acquisition, transportation, storage, and delivery. The Goods remain at the risk and title of the Supplier until their final acceptance by the Procuring Entity.

	<p><b>Transportation –</b>                  Where the Supplier is required under Contract to deliver the Goods CIF, CIP or DDP, transport of the Goods to the port of destination or such other named place of destination in the Philippines, as shall be specified in this Contract, shall be arranged and paid for by the Supplier, and the cost thereof shall be included in the Contract Price.</p> <p>Where the Supplier is required under this Contract to transport the Goods to a specified place of destination within the Philippines, defined as the Project Site, transport to such place of destination in the Philippines, including insurance and storage, as shall be specified in this Contract, shall be arranged by the Supplier, and related costs shall be included in the Contract Price.</p> <p>Where the Supplier is required under Contract to deliver the Goods CIF, CIP or DDP, Goods are to be transported on carriers of Philippine registry. In the event that no carrier of Philippine registry is available, Goods may be shipped by a carrier which is not of Philippine registry provided that the Supplier obtains and presents to the Procuring Entity certification to this effect from the nearest Philippine consulate to the port of dispatch. In the event that carriers of Philippine registry are available, but their schedule delays the Supplier in its performance of this Contract the period from when the Goods were first ready for shipment and the actual date of shipment the period of delay will be considered <i>force majeure</i> in accordance with <b>GCC</b> Clause 22.</p> <p>The Procuring Entity accepts no liability for the damage of Goods during transit other than those prescribed by INCOTERMS for DDP Deliveries. In the case of Goods supplied from within the Philippines or supplied by domestic Suppliers risk and title will not be deemed to have passed to the Procuring Entity until their receipt and final acceptance at the final destination.</p> <p><b>Patent Rights –</b>                  The Supplier shall identify the Procuring Entity against all third-party claims of infringement of patent, trademark, or industrial design rights arising from use of the Goods or any part thereof.</p> <p>For the given project in this Contract as awarded, all bid prices are considered fixed prices, and therefore not subject to price escalation during contract implementation, except under extraordinary circumstances and upon prior approval of the GPPB in accordance with Section 61 of R.A 9184 and its 2016 Revised IRR.</p>
<p>2.2</p>	<p>The terms of payment shall be <b>one (1) time payment.</b></p> <p><b>Payment shall be made by check for local supplier/manufacturer or through LC in case of foreign supplier /manufacturer.</b></p> <p>Payments shall be made only upon a certification by the <b>HoPE</b> to the effect that the Goods have been <b>rendered</b> or <b>delivered</b> in accordance with the</p>



	<p>prescribed delivery schedule of this Contract and have been duly <b>inspected</b> and <b>accepted</b>.</p>
<p>4</p>	<p>The inspections and tests that will be conducted are:</p> <p><b>A. POST-QUALIFICATION</b> involving documents validation and plant/office visit and inspection of sample goods shall be conducted by the Procuring Entity or its designated representatives (PQ Team designated by the BAC) to determine the compliance to the requirements of the end-user as required in the bidding documents. Manufacturer’s plant inspection will be conducted, subject to the approval of the Head of the Procuring Entity (HOPE). The Manufacturer/Supplier shall be made to provide pieces of evidence of the compliance of items offered to the specifications as stated in Section VII of the bidding documents and his capability to manufacture/supply the goods/items being required. Expenses incurred related hereto particularly travel and board and lodging expenses shall be borne by the Procuring Entity.</p> <p><b><u>Moreover, the PQ Team will conduct validation to other government agencies if the supplier/manufacturer is not blacklisted.</u></b></p> <p><b>B. PRE-SHIPMENT/PRE-DELIVERY INSPECTION AND TEST:</b></p> <p>All items shall be subjected to Pre-Delivery Inspection (PDI) by the Philippine Army.</p> <p><b>1. <u>For Foreign Manufacturers:</u></b></p> <p><b>a.</b> All Items shall be subjected to pre-shipment/ pre-delivery inspection and the test (PDI) by the Philippine Army representatives. The PDI shall be conducted not later than sixty (60) days prior to the expiry of the required delivery period at the goods’ country of origin.</p> <p><b>b.</b> The Inspection Team that may attend the pre-shipment/pre-delivery test at the country of origin at supplier’s expenses shall be composed of <b>at least five (5) members</b>.</p> <p><b>c.</b> The Manufacturer shall ensure that the Inspection Team will be allowed to jointly participate in the conduct of the testing procedures.</p> <p><b>d.</b> Supplier shall shoulder all the costs and expense of travel (via/IATA member airlines in case of international travel) and accommodation including Daily Subsistence Allowance (pursuant to Section 8, EO 298) and securing visas as necessary and travel insurance of all the Inspection Team Members. In this regard, supplier is required to <b>ISSUE the required written invitations</b> to the Inspection team through Philippine Army relative to the PDI within <b>seven (7) calendar days from receipt of NTP</b>.</p> <p><b>e.</b> Supplier shall conduct product/inspection and pre-departure briefing to orient the members of the Inspection team at least one (1) week prior to departure date. Supplier shall ensure that a full time/on-board</p>

interpreter is available for non-English speaking country of manufacturer/plant site. Travel documents including insurance must be submitted to the inspection team during the pre-departure briefing.

f. Failure to provide such invitation per paragraph *d* above may result in delays in release of required travel orders for the inspection team and may subject the supplier to applicable sanctions including liquidated damages due to late delivery.

*The PDI shall be conducted in accordance with the prescribed PA Test and Acceptance Procedures or if “Manufacturer’s Standard” is reflected as to the requirement in the PA TS/TAP, the Manufacturer’s TS and TAP must be in accordance to NATO or equivalent standard.*

**Cost of testing including the cost of sample shall be for the account of the supplier. The samples shall be over and above the quantity to be delivered.**

**2. For Local Manufacturers:**

a. Pre-delivery inspection of the items to be conducted by Philippine Army Inspection Team at the Manufacturer’s local facilities, Government Arsenal Facilities, or at an authorized third-party testing facility.

b. All incidental and related expenses relative to inspection shall be for the account of the manufacturer.

c. Acceptance Tests to be conducted as per prescribed Test and Acceptance Procedures. **(Annex 7-C) Cost of samples to be used for testing shall be for the account of the manufacturer. The samples shall be over and above the quantity to be delivered.**

**SPECIFICATIONS:**

Lot	Description	Technical Specifications	Test and Acceptance Procedure
1	Grenade Launcher, 40mm	PA SPECS NR FAM – 33(UB) – 08 - 20	PA TAP NR FAM – 33(UB) – 04 - 20

**All items to be supplied must come from one (1) source and manufacturer only.**

**Date of Manufacture of Item:** All items must have a manufacturing date which should not be more than **one (1) year** from date of delivery (**brand new/freshly manufactured**);

**C. Final Inspection and Acceptance** will be at the Delivery Site. Completeness and appropriateness of the delivered goods shall be inspected by the Procuring Entity’s representative at the delivery site at the soonest time possible. After completion of the inspection, the inspection team shall furnish the following reports;

1. Final Inspection and Acceptance Report by the TIAC;

	<p>2. OAFM Inspection Report; 3. SAO/APAO Acceptance Report;</p> <p><b><u>Non- Acceptance of Items:</u></b></p> <p><b>Replacement of Defective Items Noted During Pre-Delivery Inspection:</b> Any defects noted during pre-delivery inspection shall be corrected prior to shipment of the Goods.</p> <p><b>Replacement of Defective Items upon Delivery and Testing of Items:</b> Any defects noted during delivery shall be corrected within the remaining days of delivery period of the Goods.</p> <p><b>In case items are rejected,</b> PA-TIAC shall issue Certificate of Non-Acceptance on the cause of non-compliant of the item.</p> <p>In case of rejection, the Goods shall be secured and shall remain under the custody of the PA until re-exported (if imported) at the expense of the supplier to include storage charges, subject to the applicable laws in the Philippines.</p> <p><u>Supplier shall be <b>subjected to blacklisting</b> due to termination by default.</u></p>
<p>5.1</p>	<p>The warranty shall be covered by, either retention money in an amount equivalent to <b>five percent (5%)</b> of every progress payment, or a special bank guarantee equivalent to <b>five percent (5%)</b> of the Contract Price in favor of the Armed Forces of the Philippines.</p> <p>The warranty period shall be one (1) year after acceptance by the Procuring Entity of the Delivered Goods. The manufacturer shall issue a Warranty Certificate that shall cover a minimum of one (1) year after the acceptance by the Procuring Entity of the Delivered Goods.</p> <p>The Obligation for the warranty shall only be released after the lapse of the warranty period.</p> <p>The PROCURING ENTITY through the TIAC may invoke for warranty claims for the GOODS or any part thereof that fail to conform to the specifications within the warranty period. The Supplier shall either rectify or replace such defective GOODS or parts thereof or make alterations necessary to meet the specifications at no cost to the PROCURING ENTITY, and shall inspect the rectified/replaced goods, at no cost to the PROCURING ENTITY, upon giving a notice pursuant to GCC Clause 5.2.</p>
<p>5.2</p>	<p>The period for repair or replacement for the defective goods or parts thereof shall be within Ninety (90) Calendar Days (maximum) upon receipt of the Notice of Defects.</p>

## SECTION VI. SCHEDULE OF REQUIREMENTS

### ***Section VI. Schedule of Requirements***

The delivery schedule expressed as weeks/months stipulates hereafter a delivery date which is the date of delivery to the project site.

Lot	Description	Qty	Unit	Delivery Period
1	Grenade Launcher, 40mm	1,024	units	<b>One Hundred Eighty (180) Calendar Days upon receipt of NTP</b> by the supplier, which date shall not be later than seven (7) calendar days from the issuance of NTP; should the supplier fail to comply, the delivery period shall commence.
2	Cut-away, Grenade Launcher, 40mm	5	units	
3	Tools for installation and basic maintenance	1,024	sets	
4	Cleaning Paraphernalia (minimum) <ul style="list-style-type: none"> <li>- Bore Brush with Cleaning Rod or Pull Cord for Breech to Muzzle Cleaning</li> <li>- Parts Brush</li> <li>- Gun Oil (25ml)</li> <li>- Case or Pouch for the cleaning paraphernalia</li> </ul>	1,024	sets	
5	User or Operator's Manual that shall include the following: <ul style="list-style-type: none"> <li>- Description and Theory of Operation</li> <li>- Operator Instructions</li> <li>- Troubleshooting Procedures</li> <li>- Maintenance Instructions</li> <li>- Additional Supporting Information</li> </ul>	1,024	pcs	
6	Technical Manual that shall include the following: <ul style="list-style-type: none"> <li>- Basic Issue Items List</li> <li>- Repair Parts</li> <li>- Special Tools List</li> <li>- Technical Data/Specifications of the weapon</li> </ul>	50	pcs	

7	Armorer's Tool Kit (minimum) <ul style="list-style-type: none"> <li>- Hammer (Ball Peen) 10oz</li> <li>- Hammer (Dead Blow) Rubber 5oz</li> <li>- Bench Block (Mechanical)</li> <li>- Hex Key Set (Allen) 0.05in–3/8in</li> <li>- File Set Tools</li> <li>- Screw Driver (Flat Tip)</li> <li>- Screw Driver (Cross Tip)</li> <li>- Roll Pin Punch Set</li> <li>- Punch Drive Pin Set</li> <li>- Brass Drift Pin 3/8 in (6 in length)</li> <li>- Armorer's Tool Kit Casing</li> </ul>	20	sets	
8	In-country Training: <ul style="list-style-type: none"> <li>- Operation and Maintenance Training</li> </ul>	47	pax	

# SECTION VII. TECHNICAL SPECIFICATIONS

*By 2028, a world-class Army that is a source of national pride*

Technical Specifications for Launcher, Grenade, 40mm: Under Barrel  
PA SPECS NR FAM – 33(UB) – 08 – 20



**HEADQUARTERS  
PHILIPPINE ARMY  
OFFICE OF THE ARMY CHIEF ORDNANCE AND CHEMICAL SERVICE  
Fort Andres Bonifacio, Metro Manila**

PA SPECS NR FAM – 33(UB)– 08 – 20

SEP 24 2020

**TECHNICAL SPECIFICATIONS FOR  
LAUNCHER, GRENADE, 40MM: UNDER BARREL**

<b>Description:</b>	A light weight, single-shot, breach-loaded, shoulder fired weapon designed to be attached to a carbine to provide personnel with offensive and defensive capabilities to engage targets in the field
<b>Weapons Application:</b>	Carbine, 5.56mm: M4; Carbine, 5.56mm: R4A3
<b>TECHNICAL DATA</b>	<b>SPECIFICATIONS</b>
<b>PHYSICAL CHARACTERISTICS</b>	
<b>1. Caliber:</b>	40mm
<b>2. Ammunition:</b>	Ctg, 40x46mm and Ctg, 40mm (Less Lethal Rounds)
<b>3. Barrel:</b>	
3.1. Material	Manufacturer's Standard
3.2. Rifling Twist	Righthand
3.3. Finish	Manufacturer's Standard
3.4. Color	Matte Black
<b>4. Sight:</b>	Shall be provided with Leaf Sight Shall have elevation adjustment increments for ranges 50 to 400 meters
<b>5. Operating Systems:</b>	
5.1. Firing Modes	Safe, Fire
5.2. Attachment to Rifle	Shall be attached firmly to the weapon (as indicated in the weapons application) by a barrel nut adapter <b>(see figure 1 and 2)</b> Shall have a Quick Release Bracket Mounting compatible with M4A1 type barrel <b>(see figure 1 and 2)</b>
5.3. Type of Loading	Breach Loading
<b>6. Accessories:</b>	
6.1. Tools	Shall be provided with installation and basic maintenance tools per launcher
6.2. Cleaning Paraphernalia	One (1) set per launcher. Shall include the following: <ul style="list-style-type: none"> <li>• Gun oil</li> <li>• Bore/Chamber brush with cleaning rod or pull cord</li> <li>• Parts brush</li> <li>• Pouch or Case (for Cleaning Paraphernalia)</li> </ul>
6.3. Operator/User Manual	One (1) manual per launcher
<b>7. Weight and Dimensions:</b>	
7.1. Overall Weight	2.5 kgs (max)

*Honor. Patriotism. Duty.*



*[Signature]*  
Page 1 of 4

By 2028, a world-class Army that is a source of national pride

Technical Specifications for Launcher, Grenade, 40mm: Under Barrel  
PA SPECS NR FAM – 33(UB) – 08 – 20

7.2. Overall Length	15.5 in (max)
7.3. Barrel Length	10 -12 in
<b>8. Packaging:</b>	
8.1. Inner	One (1) Launcher per airtight, watertight ethylene bag
8.2. Intermediate	One (1) Launcher with accessories per Carton Box
8.3. Outer	Manufacturer's Standard
<b>9. Markings:</b>	
9.1. Body	Shall bear the marking "AFP Property" etched on the body in addition to Standard Manufacturer's Markings and Serial Numbering System
9.2. Intermediate Packaging	Nomenclature
	Serial number/s
9.3. Outer Packaging	Item/s contents name
	<b>PH Government Property</b>
	<b>Philippine Army</b>
	Nomenclature
	Packing lists
	Weight of contents
	Dimension
	Manufacturer and Country of Origin
<b>PERFORMANCE CHARACTERISTICS</b>	
<b>10. Trigger Pull:</b>	Shall be free from creep Shall be within 2.3 – 5.0 kgs
<b>11. Rate of Fire:</b>	5 rounds per minute (min)
<b>12. Targeting and Accuracy:</b>	The center of impact of 20 round group shall be within targeting rectangle of 36.6 meters in range and 6.36 meters in deflection with the 200-meter aiming point as the center
	20-round group shall have one range probable error of less than 4.3 meters (14 feet) and one deflection probable error of less than 0.9 meters (3 feet) when fired at 200 meters
<b>13. Maximum Range:</b>	Shall not be less than 350 meters
<b>14. Drop Safety:</b>	Weapon shall not fire upon impact on a hard ground after being dropped from a minimum height of 1.3 meter
	Shall be free from functional defects when fired
<b>15. Interchangeability:</b>	All parts shall be interchangeable
	Weapon shall be free from functional defects when fired
<b>16. Functional Test:</b>	Shall be free from functional defect after firing a total of 72 rounds
<b>17. Other Requirements:</b>	
17.1. Armorer's tool kit	As specified in the Contract
17.2. Technical manual	
17.3. Cut-away	
17.4. Certificate	The specific model of the launcher was fired with at least 1,000 rounds without any malfunction or damages

Honor. Patriotism. Duty



By 2028, a world-class Army that is a source of national pride

Technical Specifications for Launcher, Grenade, 40mm, Under Barrel  
PA SPECS NR FAM – 33(UB) – 08 – 20

Figure 1

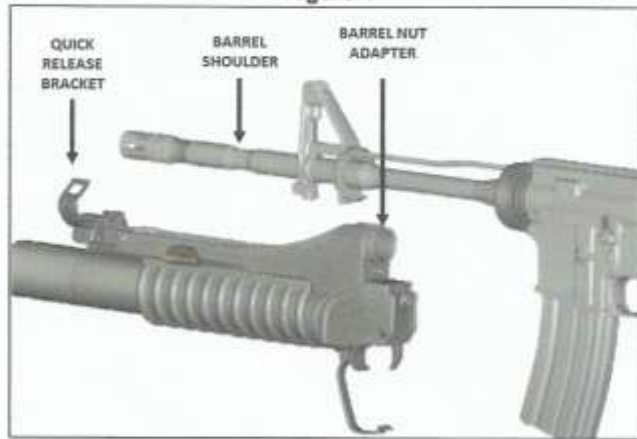

Figure 2



Honor. Patriotism. Duty

Page 3 of 4



*By 2028, a world-class Army that is a source of national pride*  
Technical Specifications for Launcher, Grenade, 40mm, Under Barrel  
PA SPECS NR FAM - 33(UB) - 08 - 20

**PREPARED BY:**

  
**DARREL P MARIANO**  
Major (OS) PA  
Chief, PRB

  
**ROXANNE R SANTOS**  
Captain (OS) PA  
Chief, FB

**RECOMMENDED BY:**

  
**FLORENTE P SISON**  
Colonel MNSA PA  
Chief

**APPROVED BY:**

  
**CIRILITO E SOBEJANA**  
Lieutenant General PA  
Commanding General

*Honor. Patriotism. Duty.*



*By 2028, a world-class Army that is a source of national pride.*

*Test and Acceptance Procedure for Launcher, Grenade, 40mm: Under Barrel  
PA TAP NR FAM – 33(UB) – 04 – 20*



HEADQUARTERS  
PHILIPPINE ARMY  
OFFICE OF THE ARMY CHIEF ORDNANCE AND CHEMICAL SERVICE  
Fort Andres Bonifacio, Metro Manila

PA TAP NR FAM – 33(UB)– 04 – 20

SEP 24 2020

**TEST AND ACCEPTANCE PROCEDURE FOR  
LAUNCHER, GRENADE, 40MM: UNDER BARREL**

**1. REFERENCES:**

- 1.1. Technical Specifications for Launcher, Grenade, 40mm: Under Barrel dated \_\_\_\_\_.
- 1.2. MIL-L-45935A Military Specification for Launcher, Grenade, 40mm: Detachable, M203 dated 05 September 1974 (reactivated 21 January 2011).
- 1.3. ANSI/ASQ Z1.4-2003; Sampling Procedures and Tables for Inspection by Attributes.

**2. OBJECTIVES:**

- 2.1 To determine the functional reliability of the weapon.
- 2.2 To determine the performance of the weapon when subjected to adverse field and storage conditions.
- 2.3 To determine user safety when weapon is fired in various environmental conditions.
- 2.4 To ascertain compliance to standards and specifications.

**3. GUIDELINES:**

- 3.1 The manufacturer/supplier shall ensure that the complete quantity stated in the contract is packed/palletized prior to the inspection.
- 3.2 Technical inspection and test shall be conducted on the representative samples of the lot through visual/physical, weight and dimensional measurements to determine the over-all workmanship, markings, color and appropriate packaging of the items.
- 3.3 Functional Test will be done to determine the functional performance of the weapon.
- 3.4 Results obtained shall be recorded and evaluated to determine the compliance of the items to technical specifications and as basis for acceptance or rejection of the lot or lots.

**4. PROCEDURES:**

**4.1 COMPLETENESS INSPECTION AND RANDOM SAMPLING:**

The Technical Inspection and Acceptance Committee (TIAC) for Ordnance-Firepower/ Pre-Delivery Inspection (PDI) Team shall check the



*Honor. Patriotism. Duty*

Page 1 of 8

*By 2028, a world-class Army that is a source of national pride.*

*Test and Acceptance Procedure for Launcher, Grenade, 40m. Under Barrel  
PA TAP NR FAM – 33(UB) – 04 – 20*

completeness of the goods and conduct random sampling from the lot or lots. The samples shall be properly segregated, packed, marked and secured by the members. (See Para 4.3. – Allocation and Criteria for Representative Samples)

#### 4.2. TEST AND INSPECTION PARAMETERS:

##### 4.2.1. PHYSICAL INSPECTION:

##### 4.2.1.1. FOR THE PACKAGING:

**4.2.1.1.1. Purpose:** This non-destructive test shall be performed to determine the overall workmanship, conformity to technical specifications of the packaging and its markings to ensure that the inspected item shall be free from defects and meet the requirements of the Philippine Army.

##### 4.2.1.1.2. Procedures:

**4.2.1.1.2.1.** Visually check the packaging.

**4.2.1.1.2.2.** Inspect the presence and appropriateness of the markings.

**4.2.1.1.2.3.** Inspect for signs of deterioration, condition of handles, loose, missing or incorrect positioned parts.

**4.2.1.1.2.4.** Check for the compliance of the packaging material using appropriate instruments that will precisely identify the composition of the materials. In the absence of facility or equipment, a certification or manufacturing test result shall be provided.

**4.2.1.1.2.5.** Record all observations.

**4.2.1.1.3. Standards:** The packaging shall be free from defects as stated in the **Types and Classifications of Defects- Visual Inspection - Packaging.**

##### 4.2.1.2. FOR THE LAUNCHER:

**4.2.1.2.1. Purpose:** This non-destructive test shall be performed to determine the overall workmanship, conformity to technical specifications of the launcher and to ensure that it is free from defect and meet the requirement of the Philippine Army.

##### 4.2.1.2.2. Procedures:

**4.2.1.2.2.1.** The sample launcher, its parts or components shall be visually inspected for its compliance on the physical/material technical data requirement using X-Ray Fluorescence (XRF) spectrometers/ analyzers or other appropriate instruments that will precisely identify the composition of the materials. In the absence of facility or equipment, a certification or manufacturing test result shall be provided.

**4.2.1.2.2.2.** Inspect for the presence and appropriateness of markings.

**4.2.1.2.2.3.** Each sample shall be examined for presence/ evidence of defect on workmanship.

**4.2.1.2.2.4.** The launcher shall be attached to the standard weapon (as indicated in the weapons application or its equivalent).



Honor. Patriotism. Duty

Page 2 of 8

*By 2028, a world-class Army that is a source of national pride.*

*Test and Acceptance Procedure for Launcher, Grenade, 40mm; Under Barrel  
PA TAP NR FAM – 33(LUB) – 04 – 20*

**4.2.1.2.2.5.** Inspect for compatibility and other requirements as indicated in the technical specification.

**4.2.1.2.2.6.** Record all observations.

**4.2.1.2.3. Standard:** The launcher shall be free from defects as stated in the **Types and Classifications of Defects- Physical Inspection- Launchers.**

**4.2.2. WEIGHT AND DIMENSIONAL INSPECTION:**

**4.2.2.1. Purpose:** This test shall be performed to determine compliance of the launcher to the provided weight and dimensional requirement in the technical specifications of the Philippine Army.

**4.2.2.2. Procedures:**

**4.2.2.2.1.** The sample launcher, its parts or components shall be measured by using a weighing scale, go and no-go gages, vernier caliper, micrometer caliper or other appropriate measuring instruments.

**4.2.2.2.2.** Record the weight and dimensions.

**4.2.2.3. Standard:** The launcher shall be free from defects as stated in the **Types and Classifications of Defects- Weight and Dimensional Inspection.**

**4.2.3. PERFORMANCE TESTS:**

A series of tests shall be performed to ensure that the launcher will efficiently function and perform accordingly based on the established standards and specifications when subjected to various methods of actuation simulating field usage and storage conditions.

**4.2.3.1. TRIGGER PULL TEST:**

**4.2.3.1.1. Purpose:** This test shall be performed to determine conformity of the trigger pull of the launcher as required in the technical specifications.

**4.2.3.1.2. Procedure:**

**4.2.3.1.2.1.** Measure the trigger pull using force gauge or any equivalent.

**4.2.3.1.2.2.** Observe for creep or any irregular trigger behavior by manually pulling the trigger.

**4.2.3.1.2.3.** Record observations.

**4.2.3.1.3. Standard:** Trigger pull shall be according to specification.

**4.2.3.2. RATE OF FIRE TEST:**

**4.2.3.2.1. Purpose:** This test shall be performed to determine conformity of the launcher's rate of fire.



Honor. Patriotism. Duty

Page 3 of 8

*By 2028, a world-class Army that is a source of national pride.*

*Test and Acceptance Procedure for Launcher, Grenade, 40mm: Under Barrel  
PA TAP NR FAM – 33(UB) – 04 – 20*

**4.2.3.2.2. Procedures:**

4.2.3.2.2.1. The launcher shall be attached to a standard weapon (as indicated in the weapons application or its equivalent).

4.2.3.2.2.2. Using appropriate type of ammunition, the handheld weapon shall be fired as many rounds as possible for a duration of one minute.

4.2.3.2.2.3. Repeat three (3) times and note the average.

**4.2.3.2.3. Standard:**

4.2.3.2.3.1. The average rate of fire of the launcher shall be within the specification.

4.2.3.2.3.2. The launcher shall be free from defects as stated in the **Types and Classifications of Defects - Functional Defects**.

**4.2.3.3. TARGETING AND ACCURACY TEST:**

4.2.3.3.1. **Purpose:** This test shall be performed to determine conformity of the accuracy of the launcher when fired at 200 meters.

**4.2.3.3.2. Procedures:**

4.2.3.3.2.1. The launcher shall be attached to a standard weapon (as indicated in the weapons application or its equivalent). Top edge of the front sight post flange of the rifle shall be set flush with or not more than .030 inch below the bottom surface of the of the front sight slot. The leaf sight shall be unfolded to the sighting position. No adjustment of the leaf sight shall be made after it has been set in the leaf sight alignment.

4.2.3.3.2.2. On benchrest position and by using appropriate type of ammunition, 20 rounds shall be fired to the target at a distance of 200 meters.

4.2.3.3.2.3. The range and deflection of each round shall be recorded.

4.2.3.3.2.4. Compute for standard deviation (range and deflection), probable error and center of impact of the 20-round group.

4.2.3.3.2.5. Wind condition during the firing shall not exceed 10 miles per hour.

**4.2.3.3.3. Standard:**

4.2.3.3.3.1. Targeting and accuracy of the launcher shall be according to the specification.

4.2.3.3.3.2. The launcher shall be free from defects as stated in the **Types and Classifications of Defects- Functional Defects**.

**4.2.3.4. MAXIMUM RANGE TEST:**

4.2.3.4.1. **Purpose:** This test shall be performed to determine conformity of the maximum range of the launcher as required in the specifications.



Honor. Patriotism. Duty

*[Signature]*  
Page 4 of 8

*By 2028, a world-class Army that is a source of national pride.*

*Test and Acceptance Procedure for Launcher, Grenade, 40m: Under Barrel  
PA TAP NR FAM – 33(UB) – 04 – 20*

**4.2.3.4.2. Procedures:**

**4.2.3.4.2.1.** The launcher shall be attached to the standard weapon (as indicated in the weapons application or its equivalent).

**4.2.3.4.2.2.** Conduct any applicable or appropriate testing procedure that will properly identify the maximum range of the launcher shall be conducted.

**4.2.3.4.2.3.** Record observations

**4.2.3.4.3. Standard:**

**4.2.3.4.3.1.** Maximum Range of the launcher shall be according to specification.

**4.2.3.4.3.2.** The launcher shall be free from defects as stated in the **Types and Classifications of Defects- Functional Defects.**

**4.2.3.5. DROP SAFETY TEST:**

**4.2.3.5.1. Purpose:** To determine durability and whether the launcher will fire upon impact when dropped.

**4.2.3.5.2. Procedures:**

**4.2.3.5.2.1.** The launcher shall be attached to the standard weapon (as indicated in the weapons application or its equivalent).

**4.2.3.5.2.2.** Conduct any applicable or appropriate testing procedure that will properly determine safety of the launcher when dropped from a height of 1.3 meters.

**4.2.3.5.2.3.** Inspect the weapon and ascertain the position of the safety switch and check to see if the launcher has fired.

**4.2.3.5.2.4.** Conduct firing test if the serviceability of the launcher is questionable.

**4.2.3.5.2.5.** Record observations.

**4.2.3.5.3. Standard:** Performance of the launcher shall be according to specification.

**4.2.3.6. INTERCHANGEABILITY TEST:**

**4.2.3.6.1. Purpose:** To determine the interchangeability of the parts of the launcher.

**4.2.3.6.2. Procedures:**

**4.2.3.6.2.1.** Launcher shall be tested for interchangeability of parts by disassembling the launcher and interchanging the parts using appropriate procedures.

**4.2.3.6.2.2.** The launcher shall be re-assembled and shall be tested for trigger pull and functional firing of two (2) rounds per launcher.

**4.2.3.6.3. Standard:**

**4.2.3.6.3.1.** Performance of launcher shall be according to specification.

**4.2.3.6.3.2.** The launcher shall be free from defects as stated in the **Types and Classifications of Defects- Functional Defects.**



*Honor. Patriotism. Duty*

Page 5 of 8

*By 2028, a world-class Army that is a source of national pride.*  
 Test and Acceptance Procedure for Launcher, Grenade, 40mm: Under Barrel  
 PA TAP NR FAM – 33(LB) – 04 – 20

**4.2.3.7. FUNCTIONAL TEST:**

**4.2.3.7.1. Purpose:** To determine if the launcher can withstand firing of 72 rounds without malfunction and damage.

**4.2.3.7.2. Procedures:**

**4.2.3.7.2.1.** The launcher cleaned and lightly oiled shall be attached to the standard weapon (as indicated in the weapons application) and set on a rifle rest.

**4.2.3.7.2.2.** Set the fire selector to Safe position then pull the trigger to check whether the launcher will fire or not

**4.2.3.7.2.3.** Using appropriate type of round, a four (4) 18-round series shall be fired from the launcher. Each series shall be fired within 4 minutes including reloading time.

**4.2.3.7.2.4.** Conduct visual, gauging and crack inspection as applicable to determine damage on the launcher after each series.

**4.2.3.7.2.5.** Record observation.

**4.2.3.7.2.6.** A 15-minute cooling period and preparation is allowed between each series.

**4.2.3.7.3. Standard:** Performance of the launcher shall be according to specification.

*Note: During the test, the proponent is allowed to clean the launcher after each test/functional firing in preparation for the next test. However, cleaning shall be done in the presence of test team members.*

**4.2. ALLOCATION AND CRITERIA FOR REPRESENTATIVE SAMPLES:**  
 (Based on the attached Sampling Plans for launcher).

TYPE OF INSPECTION/ TEST	NR OF SAMPLES	CRITERIA
<b>A. Physical Inspection:</b>		
1. For the Packaging	100% of the Quantity of samples indicated in Table 1 corresponding to the total number of packaging for lot size.	Sampling Plan for Test and Acceptance of Firearms - Small Arms - Cal .22 up to 30mm and Launchers (Attached)
2. For the Launchers	100% of the Quantity of samples indicated in Table 1 corresponding to the lot size.	Sampling Plan for Test and Acceptance of Firearms - Small Arms - Cal .22 up to 30mm and Launchers
<b>Weight and Dimensional Inspection:</b>		
3. Overall Weight 4. Overall Length 5. Barrel Length	100% of the quantity of samples indicated in Table 1 corresponding to the total number of lot size.	Sampling Plan for Test and Acceptance of Firearms - Small Arms - Cal .22 up to 30mm and Launchers
<b>B. Performance Tests:</b> (Samples to undergo the test shall be taken from the representative samples that passed the Physical Inspection)		
1. Trigger Pull Test	100% of the quantity of samples indicated in Table 2 corresponding to the total number of lot size.	Sampling Plan for Test and Acceptance of Firearms - Small Arms - Cal .22 up to 30mm and Launchers
2. Rate of Fire Test	1 Launcher	Note 1
3. Targeting and Accuracy Test	1 Launcher	Note 1



Honor. Patriotism. Duty



Page 6 of 8

By 2028, a world-class Army that is a source of national pride.

Test and Acceptance Procedure for Launcher, Grenade, 40m: Under Barrel  
PA TAP NR FAM – 33(UB) – 04 – 20

4. Maximum Range Test	1 Launcher	Note 1
5. Drop Safety Test	1 Launcher	Note 1
6. Interchangeability Test	4 Launcher	Note 2
7. Functional Test	1 Launcher	Note 1
<b>C. Other Requirement:</b>		
Certificate	-	Note 3

**Notes:**

- 1 - Failure of the sample to comply with the applicable requirement/s shall cause for the failure of test and rejection of the lot.
- 2 - Failure of any sample to comply with the applicable requirement/s shall cause for the failure of test subject to testing of a second sample. If any sample fails from the second test, the lot shall be rejected.
- 3 - Failure of the manufacturer to provide the requirement shall cause for the rejection of the lot.

**5. TYPES AND CLASSIFICATIONS OF DEFECTS:**

TYPES OF DEFECTS	CLASSIFICATION OF DEFECTS		
	CRIT	MAJ	MIN
<b>A. Physical Inspection:</b>			
<b>For the Packaging:</b>			
- Type or material not according to specifications		X	
- Number of item/s per packaging requirement not according to specification		X	
- Damaged, missing and incorrectly positioned parts			X
- Incorrect, missing, or illegible marking			X
- Evidence of poor workmanship			X
<b>For the Launcher:</b>			
- Caliber not according to specification		X	
- Not compatible with ammunition indicated in the specification		X	
- Scratches, burrs, and dents affecting the serviceability of launcher		X	
- Scratches, burrs, and dents not affecting the serviceability of launcher		X	
- Damaged or missing part		X	
- Incorrect, missing, or illegible marking		X	
<b>Barrel</b>			
- Barrel material composition not according to specification		X	
- Barrel rifling twist not according to specification		X	
- Barrel finish/color not according to specification		X	
<b>Sight</b>			
- Not provided with leaf sight		X	
- Elevation adjustment increment not according to specification		X	
<b>Operating Systems</b>			
- Firing modes not according to specification		X	
- Attachment to assault rifle not according to specification		X	
- GL cannot be rigidly attached to the rifle		X	
- Quick release Bracket Mounting not provided or not compatible with M4A1 type barrel		X	
- Quick release Bracket Mounting not provided		X	
- Type of loading not according to specification		X	



Honor. Patriotism. Duty

Page 7 of 8



By 2028, a world-class Army that is a source of national pride.

Test and Acceptance Procedure for Launcher, Grenade, 40m: Under Barrel  
PA TAP NR FAM – 33(UB) – 04 – 20

Accessories			
- Accessory not according to specification			X
- Damaged or missing accessory			X
B. Weight and Dimensional Inspection:			
- Overall weight not within specification		X	
- Overall length not within specification		X	
- Barrel Length not within specification		X	
C. Performance Defects:			
- Trigger pull not free from creep		X	
- Trigger pull not within the specification		X	
Functional Defects			
- Launcher fired while on safe mode	X		
- Rupture of the launcher during firing	X		
- Evidence of injurious defect after firing		X	
- Any other damage/defect that affect the function of the launcher		X	
- Any other damage/defect that do not affect the function of the launcher			X

**3. ACCEPTANCE AND REJECTION:**

Acceptability of lot/s shall be determined by using the Acceptance Quality Limit (AQL) indicated in the Acceptance Criteria Tables for Physical Inspection and Performance Test based on ANZI/ASQ Z1.4-2003: Sampling Procedures and Tables for Inspection by Attributes/MIL-STD 105E: Sampling Procedures and Tables for Inspection by Attributes dated 10 May 1989.

**4. RESULT:**

The result of the test based on the above criteria shall be the basis of the Philippine Army Technical Inspection and Acceptance Committee (PA-TIAC) for Ordnance-Firepower/Pre-Delivery Inspection (PDI) Team in the acceptance or rejection of the goods/items.

**PREPARED BY:**

  
**DARREL P MARIANO**  
 Major (OS) PA  
 Chief, PRB

  
**ROXANNE R SANTOS**  
 Captain (OS) PA  
 Chief, FB

**APPROVED BY:**

  
**FLORANTE P SISON**  
 Colonel, MNSA PA  
 Chief



Honor. Patriotism. Duty.

By 2028, a world-class Army that is a source of national pride.

SAMPLING PLAN FOR THE TEST AND ACCEPTANCE OF FIREARMS  
(For Small Arms - Cal .22 up to 30mm and Launchers)



HEADQUARTERS  
PHILIPPINE ARMY  
OFFICE OF THE ARMY CHIEF ORDNANCE AND CHEMICAL SERVICE  
Fort Andres Bonifacio, Metro Manila

SEP 24 2020

**SAMPLING PLANS FOR THE TEST AND ACCEPTANCE OF FIREARMS**  
(For Small Arms – Cal .22 up to 30mm and Launchers)

**I. REFERENCES:**

- a. ANZI/ASQ Z1.4-2003: Sampling Procedures and Tables for Inspection by Attributes.
- b. Military Standard 105E dtd 10 May 89, Subject: Sampling Procedures and Tables for Inspection by Attributes.

**II. ACCEPTANCE AND REJECTION:**

Acceptability of lot/s shall be determined by using the Acceptance Quality Limit (AQL) indicated in the following Sampling Plan Tables for Visual Inspection, Dimensional Inspection, Performance Test, and Functional Test.

If the number of defects found in the first sample is equal to or less than the first **Acceptance (Ac)** number, the lot or batch shall be accepted. If the number of defects found in the first sample is equal to or greater than the first **Rejection (Re)** number, the lot or batch shall be rejected.

If the number of defects found in the first sample is between the first **Acceptance (Ac)** and **Rejection (Re)** numbers, second samples shall be inspected. The number of defects found in the first and second samples shall be accumulated. If the cumulative number of defects is equal to or less than the second acceptance number, the lot or batch shall be accepted. If the cumulative number of defects is equal to or greater than the second rejection number, the lot or batch shall be rejected.

**A. For Physical Inspection of Firearms and Packaging:** Double Sampling Plan for Normal Inspection of General Inspection Level II

Table 1

Lot Size	Sample Size Code	Sampling	Nr of Samples	Classification of Defects (AQL)			
				Major (2.5)		Minor (4.0)	
				Ac	Re	Ac	Re
2 - 8	A	1	2	0	1	0	1
		2	-	-	-	-	-
9 - 15	B	1	2	0	1	0	1
		2	-	-	-	-	-



Honor. Patriotism. Duty

*[Signature]*  
Page 1 of 3



By 2028, a world-class Army that is a source of national pride.

SAMPLING PLAN FOR THE TEST AND ACCEPTANCE OF FIREARMS  
(For Small Arms - Cal. 22 up to 30mm and Launchers)

16 - 25	C	1	3	0	1	0	1
		2	-	-	-	-	-
26 - 50	D	1	5	0	1	0	2
		2	5	-	-	1	2
51 - 90	E	1	8	0	2	0	2
		2	8	1	2	1	2
91 - 150	F	1	13	0	2	0	3
		2	13	1	2	3	4
151 - 280	G	1	20	0	3	1	4
		2	20	3	4	4	5
281 - 500	H	1	32	1	4	2	5
		2	32	4	5	6	7
501 - 1,200	J	1	50	2	5	3	7
		2	50	6	7	8	9
1,201 - 3,200	K	1	80	3	7	5	9
		2	80	8	9	12	13
3,201 - 10,000	L	1	125	5	9	7	11
		2	125	12	13	18	19
10,001 - 35,000	M	1	200	7	11	11	16
		2	200	18	19	26	27
35,001 - 150,000	N	1	315	11	16	11	16
		2	315	26	27	26	27
150,001 - 500,000	P	1	500	11	16	11	16
		2	500	26	27	26	27
500,001 and over	Q	1	800	11	16	11	16
		2	800	26	27	26	27

**B. For Performance and Functional Tests of Firearms:** Double Sampling Plan for Normal Inspection of Special Inspection Level S3

Table 2

Lot Size	Sample Size Code	Sampling	Nr of Samples	Classification of Defects (AQL)					
				Critical (1.0)		Major (2.5)		Minor (6.5)	
				Ac	Re	Ac	Re	Ac	Re
2 - 15	A	1	2	0	1	0	1	0	1
		2	-	-	-	-	-	-	-
16 - 50	B	1	2	0	1	0	1	0	1
		2	-	-	-	-	-	-	-
51 - 150	C	1	3	0	1	0	1	0	2
		2	-	-	-	-	-	1	2
151 - 500	D	1	5	0	1	0	1	0	2
		2	5	-	-	-	-	1	2
501 - 3,200	E	1	8	0	1	0	2	0	3
		2	8	-	-	1	2	3	4



Honor. Patriotism. Duty.



*[Handwritten Signature]*  
Page 2 of 3

*By 2028, a world-class Army that is a source of national pride.*

SAMPLING PLAN FOR THE TEST AND ACCEPTANCE OF FIREARMS  
(For Small Arms - Cal. 22 up to 30mm and Launchers)

3,201 – 35,000	F	1	13	0	1	0	2	1	4
		2	13	-	-	1	2	4	5
35,001 – 500,000	G	1	20	0	2	0	3	2	5
		2	20	1	2	3	4	6	7
500,001 and over	H	1	32	0	2	1	4	3	7
		2	32	1	2	4	5	8	9

**III. RESULT:**

The result of the test based on the above criteria shall be the basis of the Philippine Army Technical Inspection and Acceptance Committee (PA-TIAC) for Ordnance-Firepower/Pre-Delivery Inspection (PDI) Team in the acceptance or rejection of the goods/items.

**PREPARED BY:**

  
**DARREL P MARIANO**  
 Major, (OS) PA  
 Chief, PRB

**APPROVED BY:**

  
**FLORANTE P SISON**  
 Colonel, MNSA PA  
 Chief



*Honor. Patriotism. Duty.*



*By 2028, a world-class Army that is a source of national pride.*

HEADQUARTERS  
PHILIPPINE ARMY  
OFFICE OF THE ARMY CHIEF ORDNANCE AND CHEMICAL SERVICE  
*Fort Andres Bonifacio, Metro Manila*

**SAMPLE DIAGRAM FOR MARKINGS ON PACKAGING OF**  
**FIREARMS**

**INNER PACKAGING:** (Sample Illustration, Diagram Not in Scale)

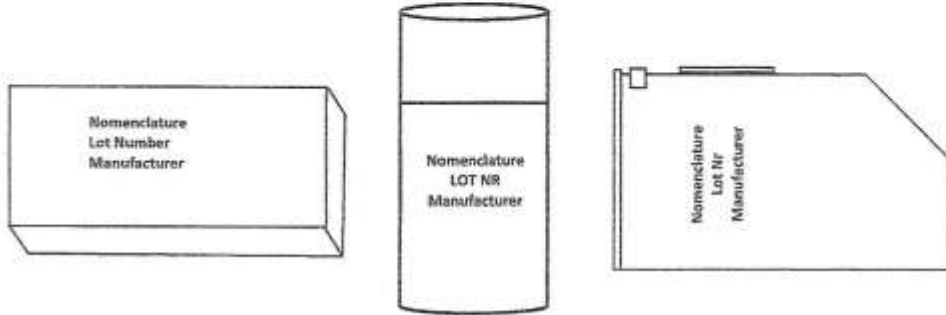

**INTERMEDIATE PACKAGING:** (Sample Illustration, Diagram Not in Scale)

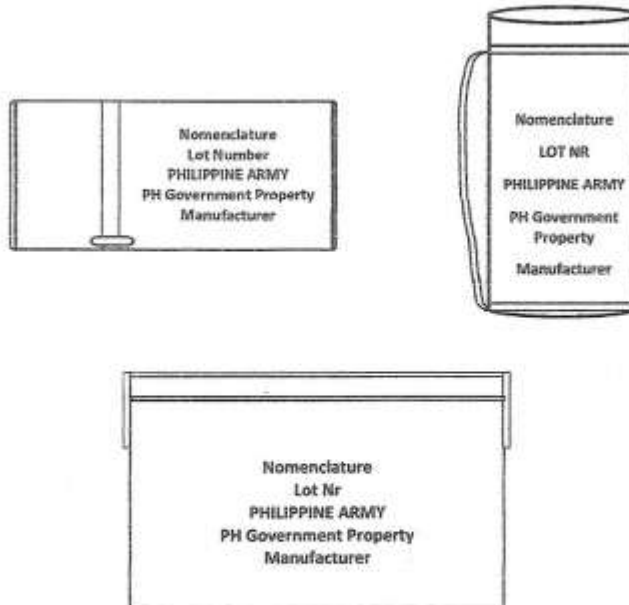

*Honor, Patriotism, Duty.*

By 2028, a world-class Army that is a source of national pride.

**OUTER PACKAGING:** (Sample Illustration, Diagram Not in Scale)

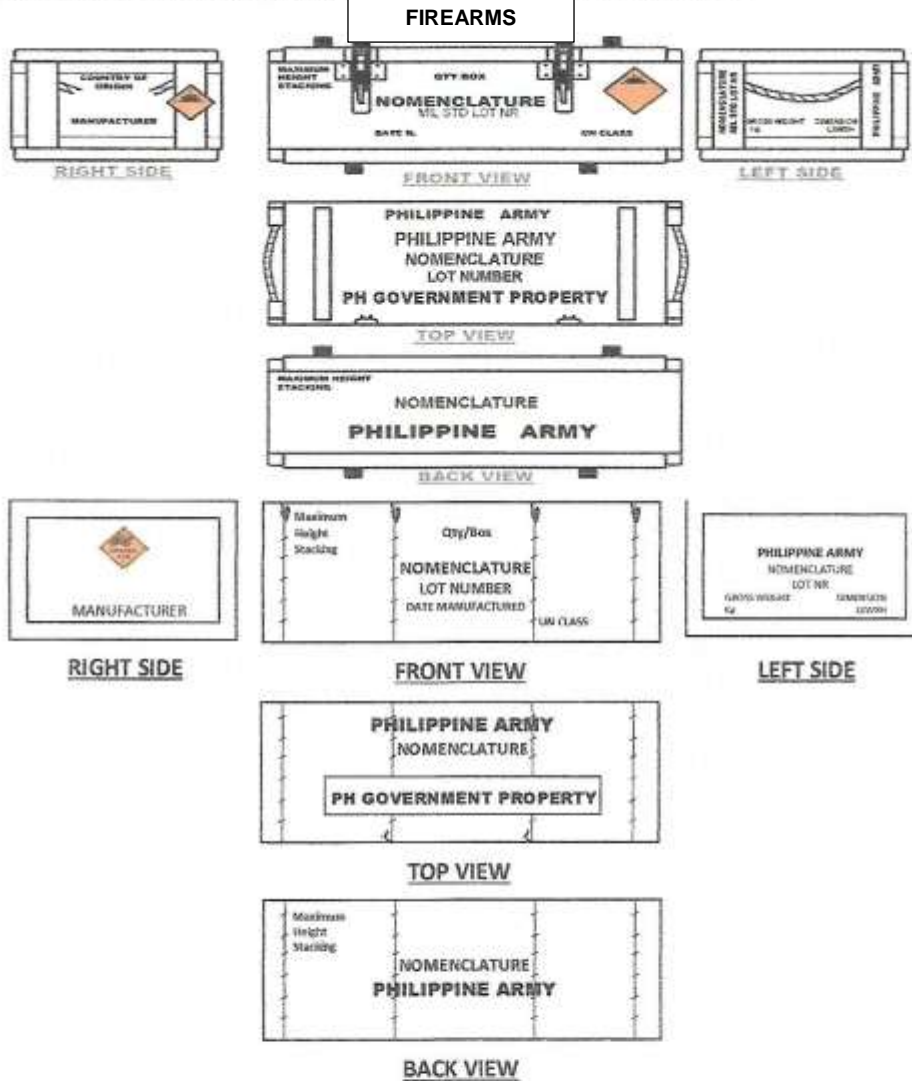

**Note:** The illustrated diagram is just an example purposely to serve as reference. Placement, font size, and font style are manufacturer's standard. Refer to Technical Specification for the minimum required markings.

PREPARED BY:

APPROVED BY:

*Darrel P. Mariano*  
 DARREL P MARIANO  
 MAJ (OS) PA  
 Chief, PRB

*Florentino P. Sison*  
 FLORENTINO P. SISON  
 Colonel, MNSA PA  
 Chief



Honor. Patriotism. Duty.

## SECTION VIII. CHECKLIST OF TECHNICAL AND FINANCIAL DOCUMENTS

TAB	I. TECHNICAL COMPONENT ENVELOPE						
<b>Class "A" Documents</b>							
<b>Legal Documents:</b>							
<b>A</b>	Valid PhilGEPS Registration Certificate (Platinum Membership) (all pages); <b>or</b>						
<b>B</b>	Registration certificate from Securities and Exchange Commission (SEC), Department of Trade and Industry (DTI) for sole proprietorship, or Cooperative Development Authority (CDA) for cooperatives or its equivalent document; <b>and</b>						
<b>C</b>	Mayor's or Business permit issued by the city or municipality where the principal place of business of the prospective bidder is located, or the equivalent document for Exclusive Economic Zones or Areas; <b>and</b>						
<b>D</b>	Tax clearance per E.O. No. 398, s. 2005, as finally reviewed and approved by the Bureau of Internal Revenue (BIR).						
<b>Technical Documents:</b>							
<b>E</b>	Statement of the prospective bidder of all its ongoing government and private contracts, including contracts awarded but not yet started, if any, whether similar or not similar in nature and complexity to the contract to be bid ( <b>Annex 1</b> ); <b>and</b>						
<b>F</b>	Statement of the bidder's Single Largest Completed Contract (SLCC) similar to the contract to be bid, except under conditions provided for in Sections 23.4.1.3 and 23.4.2.4 of the 2016 revised IRR of RA No. 9184, within the relevant period as provided in the Bidding Documents ( <b>Annex 2</b> ); <b>and</b>						
<b>G</b>	Original copy of Bid Security. If in the form of a Surety Bond, submit also a certification issued by the Insurance Commission; <b>or</b> Original copy of Notarized Bid Securing Declaration ( <b>Annex 3</b> ); <b>and</b>						
<b>H</b>	<p>1. <b>Completed and signed Conformance/Statement of Compliance</b> to Technical Bid Form, Technical Specifications (TS) and other Test and Acceptance Procedure (TAP) (with corresponding Sampling Plans and AQL); (<b>Annex 4</b>)</p> <table border="1" style="width: 100%;"> <tbody> <tr> <td style="text-align: center;"><b>Annex 4-A</b></td> <td>Technical Bid Forms</td> </tr> <tr> <td style="text-align: center;"><b>Annex 4-B</b></td> <td>Technical Specifications</td> </tr> <tr> <td style="text-align: center;"><b>Annex 4-C</b></td> <td>Test and Acceptance Procedures (Packaging and Markings) with the Sampling Plan and AQL.</td> </tr> </tbody> </table> <p>2. <b>Manufacturer's Certification of Conformance from its</b></p>	<b>Annex 4-A</b>	Technical Bid Forms	<b>Annex 4-B</b>	Technical Specifications	<b>Annex 4-C</b>	Test and Acceptance Procedures (Packaging and Markings) with the Sampling Plan and AQL.
<b>Annex 4-A</b>	Technical Bid Forms						
<b>Annex 4-B</b>	Technical Specifications						
<b>Annex 4-C</b>	Test and Acceptance Procedures (Packaging and Markings) with the Sampling Plan and AQL.						

	<p><b>Technical Department or Production Department or Quality Assurance Department or its equivalent</b>, that the firearm will be manufactured in accordance with the Philippine Army (PA) TS, TAP (with Sampling Plan &amp; AQL), Packaging, and Markings. <b>(Annex 5)</b></p> <p>3. Conformity with the <b>Schedule of Requirements. (Annex 6); and</b></p>
I	Original duly signed Omnibus Sworn Statement (OSS); and if applicable, Original Notarized Secretary's Certificate in case of a corporation, partnership, or cooperative; or Original Special Power of Attorney of all members of the joint venture giving full power and authority to its officer to sign the OSS and do acts to represent the Bidder <b>(Annex 7); and</b>
J	Warranty Undertaking <b>(Annex 8); and</b>
K	<p><b>Proof of Authority</b> of the designated representative/s for purposes of the bidding; <b>and</b></p> <p><b><u>For Local Manufacturer:</u></b></p> <p>a. <b>Duly notarized Special Power of Attorney – For Sole Proprietorship</b> if owner opts to designate a representative/s; <b>or</b></p> <p>b. <b>Duly notarized Secretary's Certificate</b> evidencing the authority of the designated representative/s, issued by the corporation, cooperative or the members of the joint venture.</p> <p><b><u>For Foreign Manufacturer:</u></b></p> <p>a. <b>Valid and Current Written Appointment</b> of the Philippine based company (as local representative of foreign manufacturer) issued by the foreign bidder. The written appointment must include detailed scope of responsibility of the local representative.</p> <p>b. <b>Duly Notarized authorization of the Philippine Based Company's representative</b> (e.g. Secretary's Certificate for Corporation, Special Power of Attorney for Sole Proprietor) with specimen signature of the authorized representative to transact with PA/AFP including address, telephone number, fax number and email address;</p> <p><b><i>Provided that in the case of unincorporated joint venture, each member shall submit a separate Special Power of Attorney and/or Secretary's Certificate evidencing the authority of the designated representatives for purposes of this bidding.</i></b></p> <p><b><i>(Note: The Secretary's Certificate, Board Resolution or Special Power of Attorney, or its equivalent document, must have a specimen signature of the bidder or its authorized representative; it must indicate in the said document the authority to transact with the Philippine Army/AFP; and it must indicate in the same document the address, telephone number, mobile phone number, fax number and email address of the bidder or its authorized representative)</i></b></p>



L	<p>Copy of Letter Request address to Headquarters Armed Forces of the Philippines Procurement Service (HAFPPS) for the issuance of Certificate that the Bidder is not <b>Blacklisted</b>; and</p> <p><b>Note:</b></p> <ol style="list-style-type: none"> <li>1. The said letter stamped or written "RECEIVED" by HAFPPS.</li> <li>2. Authorized local registered company must also submit the abovementioned document.</li> <li>3. In case of JV, <b><u>each JV Partner</u></b> must submit the same copy of letter.</li> </ol>
M	<p><b>Current and valid ISO (9001:2015) or AQAP Certificate</b> under the name of the manufacturer issued by an independent certifying agency in the name of the Manufacturer of the item.</p> <p>The validity or scope of the ISO or other certificate must cover the production, design, manufacturing, and inspection of the items subject of the bidding; <b>and</b></p>
N	<p><b>Certification</b> from the manufacturer that the Grenade Launcher being offered is the standard Grenade Launcher of the Armed Forces of the country of origin or being used by the Armed Forces of at least one (1) country; <b>and</b></p>
O	<p>Colored Manufacturer's Brochure or Literature of the product being offered.</p> <p>Internet downloads may be included to supplement the information contained in the original brochures; <b>and</b></p>
P	<p><b>Required Firearms and Ammunition License/s; and</b></p> <p><b><u>For Local Manufacturer:</u></b></p> <p>Valid and current License to Manufacture the items to be bid issued by the National Headquarters of Philippine National Police (PNP) Camp Crame, Quezon City.</p> <p><b><u>For Foreign Manufacturer:</u></b></p> <p>Philippine Representative Company's Valid and Current Indent License to deal the goods to be bid for sale to the AFP issued by the National Headquarters of Philippine National Police (PNP), Camp Crame, Quezon City.</p> <p>Note: Required license(s) presented during opening of bids shall be used for the importation of the item being bid.</p>
<b>Financial Documents:</b>	
Q	<p>The Supplier's audited financial statements, showing, among others, the Supplier's total and current assets and liabilities, stamped "received" by the BIR or its duly accredited and authorized institutions, for the preceding calendar year which should not be earlier than two (2) years from the date of bid submission; <b>and</b></p>
R	<p>The prospective bidder's computation of Net Financial Contracting Capacity (NFCC) <b>(Annex 9)</b>;</p> <p style="text-align: center;"><b>or</b></p> <p>A committed Line of Credit that must be at least equal to ten percent (10%) of the ABC of the project issued from a Universal or Commercial Bank in lieu of its NFCC computation. <b>The amount of the committed Line of Credit MUST BE MACHINE VALIDATED. (Annex 10).</b></p>

<b>Class "B" Documents</b>	
<b>S</b>	<p>If applicable, a duly signed joint venture agreement (JVA) in case the joint venture is already in existence;</p> <p style="text-align: center;"><b>or</b></p> <p>duly notarized statements from all the potential joint venture partners stating that they will enter into and abide by the provisions of the JVA in the instance that the bid is successful <b>(Annex 11-A)</b>.</p> <p style="text-align: center;"><b>or</b></p> <p>If Joint Venture is not applicable, the bidder must submit a duly signed statement stating that JVA is not applicable <b>(Annex 11-B)</b>.</p>
<b>Other documentary requirements under RA No. 9184 (as applicable)</b>	
<b>T</b>	Certification from the DTI if the Bidder claims preference as a Domestic Bidder or Domestic Entity.

<b>II. FINANCIAL COMPONENT ENVELOPE</b>	
<b>A</b>	Original of duly signed and accomplished Financial Bid Form <b>(Annex 12-A1); and</b>
<b>B</b>	Original of duly signed and accomplished Price Schedule(s) <b>(Annex 12-A2)</b> .

## ANNEXES

<b>TECHNICAL DOCUMENTS</b>	
Statement of the prospective bidder of all its ongoing government and private contracts	<b>Annex 1</b>
Statement of the bidder's Single Largest Completed Contract (SLCC) similar to the contract to be bid within five (5) years from the date of Submission and Receipt of Bids	<b>Annex 2</b>
Bid Securing Declaration	<b>Annex 3</b>
Statement of Compliance to Technical Bid Form	<b>Annex 4-A</b>
Statement of Compliance to Technical Specifications	<b>Annex 4-B</b>
Statement of Compliance to Test and Acceptance Procedures, Sampling Plan, AQL, Packaging, and Markings	<b>Annex 4-C</b>
Manufacturer's Certification on Conformance to the TS, TAP, Sampling Plan, AQL, Packaging and Markings	<b>Annex 5</b>
Conformity with the Schedule of Requirements	<b>Annex 6</b>
Omnibus Sworn Statement (OSS)	<b>Annex 7</b>
Warranty Undertaking	<b>Annex 8</b>
Certificate of Net Financial Contracting Capacity (NFCC)	<b>Annex 9</b>
Sample Form for Committed Line of Credit	<b>Annex 10</b>
Protocol/Undertaking of Agreement to enter into Joint Venture	<b>Annex 11-A</b>
Sample Format of Statement of Inapplicability of Joint Venture Agreement	<b>Annex 11-B</b>
<b>FINANCIAL DOCUMENTS</b>	
Financial Bid Form	<b>Annex 12-A1</b>
Bid Prices and applicable Price Schedules	<b>Annex 12-A2</b>

## Annex 1

**Bidder's Company Letterhead****PROCUREMENT OF GRENADE LAUNCHER, 40MM  
FOR THE PHILIPPINE ARMY****BID REF NO. ORD PABAC 027-20**

<b>Pls. Check the item being bid</b>	<b>Lot</b>	<b>Description</b>	<b>Qty (unit)</b>	<b>ABC (Pesos)</b>
	<b>1</b>	<b>Grenade Launcher, 40mm</b>	<b>1,024</b>	<b>98,196,992.00</b>

**STATEMENT OF ALL ONGOING GOVERNMENT AND PRIVATE CONTRACTS  
(INCLUDING CONTRACTS AWARDED BUT NOT YET STARTED)**

<b>(ii.1) Name of the Contract</b>	<b>(ii.2) Date of Contract</b>	<b>(ii.3) Contract Duration</b>	<b>(ii.4) Owner's Name &amp; address</b>	<b>(ii.5) Kinds of goods</b>	<b>(ii.6) Amount of Contract and Value of Outstanding Contracts</b>	<b>(ii.8) Date of Delivery</b>	<b>(ii.9) OR Nr &amp; Date, End-user's Acceptance date or Sales "Invoice with Collection Receipt (For those completed) (please attach)</b>
<b>TOTAL</b>							

**CERTIFIED CORRECT:**

\_\_\_\_\_  
Name and Signature of Authorized Representative

\_\_\_\_\_  
Position

\_\_\_\_\_  
Date

**Bidder’s Company Letterhead**

**PROCUREMENT OF GRENADE LAUNCHER, 40MM  
FOR THE PHILIPPINE ARMY**

**BID REF NO. ORD PABAC 027-20**

<b>Pls. Check the item being bid</b>	<b>Lot</b>	<b>Description</b>	<b>Qty (unit)</b>	<b>ABC (Pesos)</b>
	<b>1</b>	<b>Grenade Launcher, 40mm</b>	<b>1,024</b>	<b>98,196,992.00</b>

a. For the procurement of Non-Expendable Supplies: The Bidder must have completed a single contract that is similar to this Project, equivalent to at least fifty percent (50%) of the ABC.

b. For procurement where the Procuring Entity has determined, after the conduct of market research, that imposition of (a) will likely result to failure of bidding that will defeat the purpose of public bidding: The Bidder should comply with the following requirements:

- i. Completed at least two (2) similar contracts, the aggregate amount of which should be equivalent to at least fifty percent (50%) in the case of non-expendable supplies of the ABC for this Project; **and**
- ii. The largest of these similar contracts must be equivalent to at least half of the percentage of the ABC as required above.

(ii.1) Name of the Contract	(ii.2) Date of Contract	(ii.3) Contract Duration	(ii.4) Owner’s Name & address	(ii.5) Kinds of goods	(ii.7) Amount of Completed Contract/s	(ii.8) Date of Delivery	(ii.9) OR Nr & Date, End-user’s Acceptance date or Sales “Invoice with Collection Receipt (For those completed) <b>(please attach)</b>
<b>TOTAL</b>							

**CERTIFIED CORRECT:**

\_\_\_\_\_  
Name and Signature of Authorized Representative

\_\_\_\_\_  
Position

\_\_\_\_\_  
Date

REPUBLIC OF THE PHILIPPINES)  
CITY OF \_\_\_\_\_) S.S.

**BID SECURING DECLARATION FORM**

**PROCUREMENT OF GRENADE LAUNCHER, 40MM  
FOR THE PHILIPPINE ARMY**

**BID REF NO. ORD PABAC 027-20**

Pls. Check the item being bid	Lot	Description	Qty (unit)	ABC (Pesos)
	1	Grenade Launcher, 40mm	1,024	98,196,992.00

To: *[Insert name and address of the Procuring Entity]*

I/We<sup>1</sup>, the undersigned, declare that:

1. I/We understand that, according to your conditions, bids must be supported by a Bid Security, which may be in the form of a Bid-Securing Declaration.
2. I/We accept that: (a) I/we will be automatically disqualified from bidding for any contract with any procuring entity for a period of two (2) years upon receipt of your Blacklisting order; and, (b) I/we will pay the applicable fine provided under Section 6 of the Guidelines on the Use of Bid Securing Declaration, within fifteen (15) days from receipt of the written demand by the procuring entity for the commission of acts resulting to the enforcement of the bid securing declaration under Sections 23.1(b), 34.2, 40.1 and 69.1, except 69.1(f), of the IRR of RA 9184; without prejudice to other legal action the government may undertake.
3. I/We understand that this Bid Securing Declaration shall cease to be valid on the following circumstances:
  - (a) Upon expiration of the bid validity period, or any extension thereof pursuant to your request;
  - (b) I am/we are declared ineligible or post-disqualified upon receipt of your notice to such effect, and (i) I/we failed to timely file a request for reconsideration or (ii) I/we filed a waiver to avail of said right;
  - (c) I am/we are declared the bidder with the Lowest Calculated Responsive Bid, and I/we have furnished the performance security and signed the Contract.

IN WITNESS WHEREOF, I/We have hereunto set my/our hand/s this \_\_\_\_ day of *[month]* *[year]* at *[place of execution]*.

*[Insert NAME OF BIDDER'S AUTHORIZED REPRESENTATIVE]* *[Insert Signatory's Legal Capacity]*  
Affiant

<sup>1</sup> Select one and delete the other. Adopt the same instruction for similar terms throughout the document.

**Annex 3**  
**(PAGE 2 OF 2)**

**SUBSCRIBED AND SWORN** to before me this \_\_\_\_ day of *[month]* *[year]* at *[place of execution]*, Philippines. Affiant/s is/are personally known to me and was/were identified by me through competent evidence of identity as defined in the 2004 Rules on Notarial Practice (A.M. No. 02-8-13-SC). Affiant/s exhibited to me his/her *[insert type of government identification card used]*, with his/her photograph and signature appearing thereon, with no. \_\_\_\_\_ and his/her Community Tax Certificate No. \_\_\_\_\_ issued on \_\_\_\_ at \_\_\_\_\_.

Witness my hand and seal this \_\_\_\_ day of *[month]* *[year]*.

**NAME OF NOTARY PUBLIC**

Serial No. of Commission \_\_\_\_\_  
Notary Public for \_\_\_\_\_ until \_\_\_\_\_  
Roll of Attorneys No. \_\_\_\_\_  
PTR No. \_\_\_\_\_ *[date issued]*, *[place issued]*  
IBP No. \_\_\_\_\_ *[date issued]*, *[place issue]*

Doc No: \_\_\_\_\_  
Page No: \_\_\_\_\_  
Book No: \_\_\_\_\_  
Series of: \_\_\_\_\_

## Annex 4

**STATEMENT OF COMPLIANCE  
TO TECHNICAL SPECIFICATIONS, TEST AND ACCEPTANCE, SAMPLING  
PLANS, AQL, PACKAGING AND MARKINGS**

The bidder must state in the last column opposite each parameter and required specifications either "Comply" or "Not Comply". All pages shall be properly signed. Bidders must state here either "Comply" or "Not Comply" against each of the individual parameters of each Specification stating the corresponding performance parameter of the equipment offered. Statements of "Comply" or "Not Comply" must be supported by evidence in a Bidders Bid and cross-reference to that evidence. Evidence shall be in the form of manufacturer's un-amended sales literature, unconditional statements of specification and compliance issued by the manufacturer, samples, independent test data etc., as appropriate. A statement that is not supported by evidence or is subsequently found to be contradicted by the evidence presented will render the Bid under evaluation liable for rejection. A statement either in the Bidders statement of compliance or the supporting evidence that is found to be false either during Bid evaluation, post-qualification or the execution of the Contract may be regarded as fraudulent and render the Bidder or supplier liable for prosecution subject to the provisions of ITB Clause above goods manufactured by us.

**CLARIFICATION AND SETTLEMENT OF CONFLICTING  
INTERPRETATION OF THE TECHNICAL SPECIFICATIONS**

All clarifications regarding the technical specifications stipulated in this section will be clarified by the members of the Technical Working Group. In cases of conflicting interpretations, the nature and purpose of the equipment will be the basis of interpretation. The main basis for technical specifications and requirements is the nature and purpose of the equipment and its intended use as determined by the doctrinal application of the end-users represented herein by the Technical Working Group.

---

Name of Company (in print)

---

Signature of Company Authorized Representative

---

Name and Designation

---

Date



**Annex 4-A**  
(Page 1 of 7)

**TECHNICAL BID FORM**

**PROCUREMENT OF GRENADE LAUNCHER, 40MM  
FOR THE PHILIPPINE ARMY**

**BID REF NO. ORD PABAC 027-20**

**TO THE BIDDER:** Indicate “COMPLY” if Bidder’s Statement of Compliance meets the Technical Specifications (TS), Test Procedures and Acceptance (TAP) and other Project Requirements. DO NOT LEAVE ANY BLANK. A “YES” OR “NO” ENTRY WILL NOT BE ACCEPTED. FAILURE TO CONFORM WILL RESULT IN A RATING OF “FAILED”.

Line No.	Technical Specifications				Bidder’s Statement of Compliance
1	Lot	Description	Technical Specifications	Test and Acceptance Procedure	
	1	Grenade Launcher, 40mm	PA SPECS NR FAM – 33(UB) – 08 - 20	PA TAP NR FAM – 33(UB) – 04 - 20	
2	Manufacturing Date: Manufacturing date should be not more than one (1) year from the date of delivery				
3	We are not blacklisted.				
<b>BIDDER’S UNDERTAKING</b>					
I/WE, the undersigned bidder, having examined the Bidding Documents including Bid Bulletins, as applicable, hereby OFFER to (supply/deliver/perform) the above described items.					
I/WE undertake, if our bid is accepted, to deliver the items in accordance with the terms and conditions contained in the bid documents, including the posting if the required performance security within ten (10) calendar days from receipt of the Notice of Award. Until a formal contract is prepared and signed, thus bid is binding on us.					

\_\_\_\_\_  
Name of Company (in print)

\_\_\_\_\_  
Signature of Company Authorized Representative

\_\_\_\_\_  
Name and Designation

\_\_\_\_\_  
Date

**TECHNICAL BID FORM**

**PROCUREMENT OF GRENADE LAUNCHER, 40MM  
FOR THE PHILIPPINE ARMY**

**BID REF NO. ORD PABAC 027-20**

**TO THE BIDDER:** Indicate “COMPLY” if Bidder’s Statement of Compliance meets the Technical Specifications (TS), Test Procedures and Acceptance (TAP) and other Project Requirements. DO NOT LEAVE ANY BLANK. A “YES” OR “NO” ENTRY WILL NOT BE ACCEPTED. FAILURE TO CONFORM WILL RESULT IN A RATING OF “FAILED”.

Line No.	Additional Requirements to be provided by the Bidder, If awarded the contract	Bidder’s Statement of Compliance
4	<p><b>DELIVERY:</b></p> <p><b>a. Delivery Period: 180 calendar days</b> after Receipt of Notice to Proceed by the supplier, which date shall not be later than seven (7) calendar days from the issuance of NTP: should the supplier fail to comply, the delivery period shall commence.</p> <p><b>b. Delivery Place:</b> Armament Company, Armament and Ammunition Battalion, Logistics Support Group, Army Support Command, Philippine Army, Camp General Emilio Aguinaldo, Quezon City, Philippines</p> <p><b>c.</b> Delivery must be done in the presence of Philippine Army authorized representatives.</p>	
<p style="text-align: center;"><b>BIDDER’S UNDERTAKING</b></p> <p>I/WE, the undersigned bidder, having examined the Bidding Documents including Bid Bulletins, as applicable, hereby OFFER to (supply/deliver/perform) the above described items.</p> <p>I/WE undertake, if our bid is accepted, to deliver the items in accordance with the terms and conditions contained in the bid documents, including the posting of the required performance security within ten (10) calendar days from receipt of the Notice of Award.</p> <p>Until a formal contract is prepared and signed, this bid is binding on us.</p>		

\_\_\_\_\_  
Name of Company (in print)

\_\_\_\_\_  
Signature of Company Authorized Representative

\_\_\_\_\_  
Name and Designation

\_\_\_\_\_  
Date

**TECHNICAL BID FORM**

**PROCUREMENT OF GRENADE LAUNCHER, 40MM  
FOR THE PHILIPPINE ARMY**

**BID REF NO. ORD PABAC 027-20**

**TO THE BIDDER:** Indicate “COMPLY” if Bidder’s Statement of Compliance meets the Technical Specifications (TS), Test Procedures and Acceptance (TAP) and other Project Requirements. DO NOT LEAVE ANY BLANK. A “YES” OR “NO” ENTRY WILL NOT BE ACCEPTED. FAILURE TO CONFORM WILL RESULT IN A RATING OF “FAILED”.

Line No.	Additional Requirements to be provided by the Bidder, If awarded the contract	Bidder’s Statement of Compliance
5	<p><i>Continuation:</i>  <b>DELIVERY:</b>  <b>d.</b> The supplier must inform the PAPC at least seven (7) calendar days prior to delivery in delivery place/site. Failure to give due notice shall be a ground for non-acceptance of delivery.  <b>e.</b> Deliveries made for “safekeeping” purposes are ALLOWED. However, the Procuring Entity is not liable of any damage/s that may be incurred while the goods are on safekeep.  <b>f.</b> Other than the delivery schedule stated above, NO PARTIAL DELIVERIES are allowed.  <b>g.</b> During delivery, the Supplier shall be responsible in unloading the items from the container to the designated warehouse of the PA. All costs related to porter services, handling and other related expenses shall be borne by the Supplier. In the absence of material handling equipment at the site, the Supplier shall provide the necessary equipment such as but not limited to: forklifts, hand pallet truck, etc. At the expense of the Supplier.</p>	
<p style="text-align: center;"><b>BIDDER’S UNDERTAKING</b></p> <p>I/WE, the undersigned bidder, having examined the Bidding Documents including Bid Bulletins, as applicable, hereby OFFER to (supply/deliver/perform) the above described items.                      I/WE undertake, if our bid is accepted, to deliver the items in accordance with the terms and conditions contained in the bid documents, including the posting if the required performance security within ten (10) calendar days from receipt of the Notice of Award.                      Until a formal contract is prepared and signed, thus bid is binding on us.</p>		

\_\_\_\_\_  
Name of Company (in print)

\_\_\_\_\_  
Signature of Company Authorized Representative

\_\_\_\_\_  
Name and Designation

\_\_\_\_\_  
Date

**Annex 4-A**  
(Page 4 of 7)

**TECHNICAL BID FORM**

**PROCUREMENT OF GRENADE LAUNCHER, 40MM  
FOR THE PHILIPPINE ARMY**

**BID REF NO. ORD PABAC 027-20**

**TO THE BIDDER: Indicate “COMPLY” if Bidder’s Statement of Compliance meets the Technical Specifications (TS), Test Procedures and Acceptance (TAP) and other Project Requirements. DO NOT LEAVE ANY BLANK. A “YES” OR “NO” ENTRY WILL NOT BE ACCEPTED. FAILURE TO CONFORM WILL RESULT IN A RATING OF “FAILED”.**

Line No.	Additional Requirements to be provided by the Bidder, If awarded the contract	Bidder’s Statement of Compliance
6	<b>Issuance of End-User Certificate:</b> Pursuant to D4 CMILD-001-2017 dated Jan 26, 2017 issued by the Office of the Deputy Chief of Staff for Logistics, J4, the deadline for submission of End-user Certificate (EUC) requirements shall be within seven (7) Calendar Days upon receipt of Contract/Notice to Proceed (NTP). The letter request shall include as an attachment important documents necessary for the issuance thereof, such as specific template/format required by the foreign government and not by the foreign supplier. Failure on the part of the supplier to submit said requirements within the specified period shall not be used and acknowledge as a valid excuse or justification to warrant the extension of the contract.	
7	Warranty Period: One (1) year after final acceptance which includes full replacement of defective items free of charge.	
8	Replacement of defective Items Noted during Pre-Delivery Inspection: Any defects noted during Pre-Delivery Inspection shall be corrected prior to shipment of the goods.	
9	Replacement of defective Items upon delivery and Testing of Items: The period for repair or replacement for the defective goods or parts thereof shall be within Ninety (90) Calendar Days (maximum) upon receipt of the Notice of Defects.  In case of rejection, the firearm shall be secured and shall remain under the custody of the PA until re-exported (if imported) at the expense of the supplier, subject to the applicable laws in the Philippines.	
<p style="text-align: center;"><b>BIDDER’S UNDERTAKING</b></p> <p>I/WE, the undersigned bidder, having examined the Bidding Documents including Bid Bulletins, as applicable, hereby OFFER to (supply/deliver/perform) the above described items.</p> <p>I/WE undertake, if our bid is accepted, to deliver the items in accordance with the terms and conditions contained in the bid documents, including the posting if the required performance security within ten (10) calendar days from receipt of the Notice of Award.</p> <p>Until a formal contract is prepared and signed, thus bid is binding on us.</p>		

\_\_\_\_\_  
Name of Company (in print)

\_\_\_\_\_  
Signature of Company Authorized Representative

\_\_\_\_\_  
Name and Designation

Date

**Annex 4-A**  
(Page 5 of 7)

**PROCUREMENT OF GRENADE LAUNCHER, 40MM  
FOR THE PHILIPPINE ARMY**

**BID REF NO. ORD PABAC 027-20**

**TO THE BIDDER: Indicate “COMPLY” if Bidder’s Statement of Compliance meets the Technical Specifications (TS), Test Procedures and Acceptance (TAP) and other Project Requirements. DO NOT LEAVE ANY BLANK. A “YES” OR “NO” ENTRY WILL NOT BE ACCEPTED. FAILURE TO CONFORM WILL RESULT IN A RATING OF “FAILED”.**

Line No.	Additional Requirements to be provided by the Bidder, If awarded the contract	Bidder’s Statement of Compliance
10	<p><b>PRE-SHIPMENT/PRE-DELIVERY INSPECTION TEST:</b> All items shall be subjected to Pre-Delivery Inspection (PDI) by the Philippine Army.</p> <p><b>FOR FOREIGN MANUFACTURERS:</b></p> <p>A. All Items shall be subjected to Pre-shipment/ Pre-delivery inspection and the test (PDI) by the Philippine Army representatives. The PDI shall be conducted no later than sixty (60) calendar days prior to the expiry of the required delivery period <b>at the foreign manufacturer’s facilities</b>. No extension of delivery period shall be allowed in case of failure or refusal of supplier to comply with said PDI period.</p> <p>B. In no case shall the Supplier be relieved from responsibility relative to the delivery of the goods in the event that the PDI is delayed for any reason including issues related to travel documents (i.e. Visa, Travel authority). Appropriate penalties for the delay shall be imposed as applicable.</p> <p>C. The Inspection Team that will attend the Pre-shipment/ Pre-delivery Inspection and Tests at the country of origin at supplier’s expenses shall be composed of atleast five (5) members of the PA Inspection team.</p> <p>D. The manufacturer shall ensure that the inspection Team will be allowed to jointly participate in the conduct of the testing procedures at the option of the inspection team.</p>	
<p style="text-align: center;"><b>BIDDER’S UNDERTAKING</b></p> <p>I/WE, the undersigned bidder, having examined the Bidding Documents including Bid Bulletins, as applicable, hereby OFFER to (supply/deliver/perform) the above described items.</p> <p>I/WE undertake, if our bid is accepted, to deliver the items in accordance with the terms and conditions contained in the bid documents, including the posting if the required performance security within ten (10) calendar days from receipt of the Notice of Award.</p> <p>Until a formal contract is prepared and signed, thus bid is binding on us.</p>		

\_\_\_\_\_  
Name of Company (in print)

\_\_\_\_\_  
Signature of Company Authorized Representative

\_\_\_\_\_  
Name and Designation

\_\_\_\_\_  
Date

**TECHNICAL BID FORM**

**PROCUREMENT OF GRENADE LAUNCHER, 40MM  
FOR THE PHILIPPINE ARMY**

**BID REF NO. ORD PABAC 027-20**

**TO THE BIDDER: Indicate “COMPLY” if Bidder’s Statement of Compliance meets the Technical Specifications (TS), Test Procedures and Acceptance (TAP) and other Project Requirements. DO NOT LEAVE ANY BLANK. A “YES” OR “NO” ENTRY WILL NOT BE ACCEPTED. FAILURE TO CONFORM WILL RESULT IN A RATING OF “FAILED”.**

Line No.	Additional Requirements to be provided by the Bidder, If awarded the contract	Bidder’s Statement of Compliance
11	<p><i>Continuation:</i> <b>PRE-SHIPMENT/PRE-DELIVERY INSPECTION TEST:</b></p> <p>E. Supplier shall shoulder all the costs and expense of travel (via/IATA member airlines in case of international travel) and accommodation including Daily Subsistence Allowance (pursuant to Section 8, EO 298) and securing visas as necessary and travel insurance of all the Inspection Team Members. In this regard, supplier is required to ISSUE the required written invitations to the Inspection team through Philippine Army relative to the PDI at least seven (7) calendar days from receipt of NTP.</p> <p>F. Supplier shall conduct product/inspection and pre-departure briefing to orient the members of the Inspection team at least one (1) week prior to departure date. Supplier shall ensure that a full time/on-board interpreter is available for non-English speaking country of manufacturer/plant site. Travel documents including insurance must be submitted to the inspection team during the pre-departure briefing.</p> <p>G. Failure to provide such invitation per C above will result in delays in release of required travel orders for the inspection team which shall be the sole responsibility of the supplier and will subject the supplier to applicable sanctions including liquidated damages due to late delivery.</p> <p>Results of the Pre -Shipment Testing Procedures duly signed by Inspection Team in attendance to be submitted for payment purposes.</p>	
<p style="text-align: center;"><b>BIDDER’S UNDERTAKING</b></p> <p>I/WE, the undersigned bidder, having examined the Bidding Documents including Bid Bulletins, as applicable, hereby OFFER to (supply/deliver/perform) the above described items.</p> <p>I/WE undertake, if our bid is accepted, to deliver the items in accordance with the terms and conditions contained in the bid documents, including the posting if the required performance security within ten (10) calendar days from receipt of the Notice of Award.</p> <p>Until a formal contract is prepared and signed, thus bid is binding on us.</p>		

\_\_\_\_\_  
Name of Company (in print)

\_\_\_\_\_  
Signature of Company Authorized Representative

\_\_\_\_\_  
Name and Designation

\_\_\_\_\_  
Date

**TECHNICAL BID FORM**

**PROCUREMENT OF GRENADE LAUNCHER, 40MM  
FOR THE PHILIPPINE ARMY**

**BID REF NO. ORD PABAC 027-20**

**TO THE BIDDER:** Indicate “COMPLY” if Bidder’s Statement of Compliance meets the Technical Specifications (TS), Test Procedures and Acceptance (TAP) and other Project Requirements. DO NOT LEAVE ANY BLANK. A “YES” OR “NO” ENTRY WILL NOT BE ACCEPTED. FAILURE TO CONFORM WILL RESULT IN A RATING OF “FAILED”.

Line No.	Additional Requirements to be provided by the Bidder, If awarded the contract	Bidder’s Statement of Compliance
12	<p><i>Continuation:</i> <b>PRE-SHIPMENT/PRE-DELIVERY INSPECTION TEST:</b></p> <p>However, final acceptance as to Physical count will be conducted in the Philippines. The PDI shall be conducted in accordance with the prescribed Test and Acceptance Procedures (<b>Annex 7- C</b>). Cost of testing including the cost of sample rounds shall be for the account of supplier. The samples rounds shall be over and above the quantity to be delivered.</p> <p><b><u>FOR LOCAL MANUFACTURERS:</u></b></p> <p>H. Pre-delivery inspection of the items to be conducted at the manufacturer’s facilities, Government Arsenal, or at an authorized third-party testing center by Philippine Army Inspection Team.</p> <p>I. All expenses relative to inspection shall be for the account of the manufacturer.</p> <p>J. Acceptance Tests to be conducted as per prescribed Test and Acceptance Procedures (<b>Annex 7- C</b>). Cost of samples rounds to be used for testing shall be for the account of the manufacturer. The samples rounds shall be over and above the quantity to be delivered.</p>	
<p style="text-align: center;"><b>BIDDER’S UNDERTAKING</b></p> <p>I/WE, the undersigned bidder, having examined the Bidding Documents including Bid Bulletins, as applicable, hereby OFFER to (supply/deliver/perform) the above described items.</p> <p>I/WE undertake, if our bid is accepted, to deliver the items in accordance with the terms and conditions contained in the bid documents, including the posting if the required performance security within ten (10) calendar days from receipt of the Notice of Award.</p> <p>Until a formal contract is prepared and signed, thus bid is binding on us.</p>		

\_\_\_\_\_  
Name of Company (in print)

\_\_\_\_\_  
Signature of Company Authorized Representative

\_\_\_\_\_  
Name and Designation

\_\_\_\_\_  
Date

## Annex 4-B

By 2028, a world-class Army that is a source of national pride

Technical Specifications for Launcher, Grenade, 40mm: Under Barrel  
PA SPECS NR FAM – 33(UB) – 08 – 20



HEADQUARTERS  
PHILIPPINE ARMY  
OFFICE OF THE ARMY CHIEF ORDNANCE AND CHEMICAL SERVICE  
Fort Andres Bonifacio, Metro Manila

PA SPECS NR FAM – 33(UB)– 08 – 20

SEP 24 2020

**TECHNICAL SPECIFICATIONS FOR  
LAUNCHER, GRENADE, 40MM: UNDER BARREL**

<b>Description:</b>	A light weight, single-shot, breach-loaded, shoulder fired weapon designed to be attached to a carbine to provide personnel with offensive and defensive capabilities to engage targets in the field
<b>Weapons Application:</b>	Carbine, 5.56mm: M4; Carbine, 5.56mm: R4A3
<b>TECHNICAL DATA</b>	<b>SPECIFICATIONS</b>
<b>PHYSICAL CHARACTERISTICS</b>	
<b>1. Caliber:</b>	40mm
<b>2. Ammunition:</b>	Ctg, 40x46mm and Ctg, 40mm (Less Lethal Rounds)
<b>3. Barrel:</b>	
3.1. Material	Manufacturer's Standard
3.2. Rifling Twist	Righthand
3.3. Finish	Manufacturer's Standard
3.4. Color	Matte Black
<b>4. Sight:</b>	Shall be provided with Leaf Sight Shall have elevation adjustment increments for ranges 50 to 400 meters
<b>5. Operating Systems:</b>	
5.1. Firing Modes	Safe, Fire
5.2. Attachment to Rifle	Shall be attached firmly to the weapon (as indicated in the weapons application) by a barrel nut adapter ( <i>see figure 1 and 2</i> ) Shall have a Quick Release Bracket Mounting compatible with M4A1 type barrel ( <i>see figure 1 and 2</i> )
5.3. Type of Loading	Breach Loading
<b>6. Accessories:</b>	
6.1. Tools	Shall be provided with installation and basic maintenance tools per launcher
6.2. Cleaning Paraphernalia	One (1) set per launcher. Shall include the following: <ul style="list-style-type: none"> <li>• Gun oil</li> <li>• Bore/Chamber brush with cleaning rod or pull cord</li> <li>• Parts brush</li> <li>• Pouch or Case (for Cleaning Paraphernalia)</li> </ul>
6.3. Operator/User Manual	One (1) manual per launcher
<b>7. Weight and Dimensions:</b>	
7.1. Overall Weight	2.5 kgs (max)

Honor. Patriotism. Duty



Page 1 of 4



Annex 4-B

By 2028, a world-class Army that is a source of national pride  
 Technical Specifications for Launcher, Grenade, 40mm: Under Barrel  
 PA SPECS NR FAM – 33(LUB) – 08 – 20

7.2. Overall Length	15.5 in (max)
7.3. Barrel Length	10 -12 in
<b>8. Packaging:</b>	
8.1. Inner	One (1) Launcher per airtight, watertight ethylene bag
8.2. Intermediate	One (1) Launcher with accessories per Carton Box
8.3. Outer	Manufacturer's Standard
<b>9. Markings:</b>	
9.1. Body	Shall bear the marking "AFP Property" etched on the body in addition to Standard Manufacturer's Markings and Serial Numbering System
9.2. Intermediate Packaging	Nomenclature
	Serial number/s
9.3. Outer Packaging	Item/s contents name
	<b>PH Government Property</b>
	<b>Philippine Army</b>
	Nomenclature
	Packing lists
	Weight of contents
	Dimension
	Manufacturer and Country of Origin
<b>PERFORMANCE CHARACTERISTICS</b>	
<b>10. Trigger Pull:</b>	Shall be free from creep Shall be within 2.3 – 5.0 kgs
<b>11. Rate of Fire:</b>	5 rounds per minute (min)
<b>12. Targeting and Accuracy:</b>	The center of impact of 20 round group shall be within targeting rectangle of 36.6 meters in range and 6.36 meters in deflection with the 200-meter aiming point as the center 20-round group shall have one range probable error of less than 4.3 meters (14 feet) and one deflection probable error of less than 0.9 meters (3 feet) when fired at 200 meters
<b>13. Maximum Range:</b>	Shall not be less than 350 meters
<b>14. Drop Safety:</b>	Weapon shall not fire upon impact on a hard ground after being dropped from a minimum height of 1.3 meter Shall be free from functional defects when fired
<b>15. Interchangeability:</b>	All parts shall be interchangeable Weapon shall be free from functional defects when fired
<b>16. Functional Test:</b>	Shall be free from functional defect after firing a total of 72 rounds
<b>17. Other Requirements:</b>	
17.1. Armorer's tool kit	As specified in the Contract
17.2. Technical manual	
17.3. Cut-away	
17.4. Certificate	The specific model of the launcher was fired with at least 1,000 rounds without any malfunction or damages

Honor. Patriotism. Duty



*[Signature]*  
 Page 2 of 4

**Conforme:**

\_\_\_\_\_

Bidder's Company Name

\_\_\_\_\_

Signature of Authorized Representative

\_\_\_\_\_

Designation

\_\_\_\_\_

Date

Annex 4-B

By 2028, a world-class Army that is a source of national pride  
Technical Specifications for Launcher, Grenade, 40mm: Under Barrel  
PA SPECS NR FAM – 33(UB) – 08 – 20

Figure 1

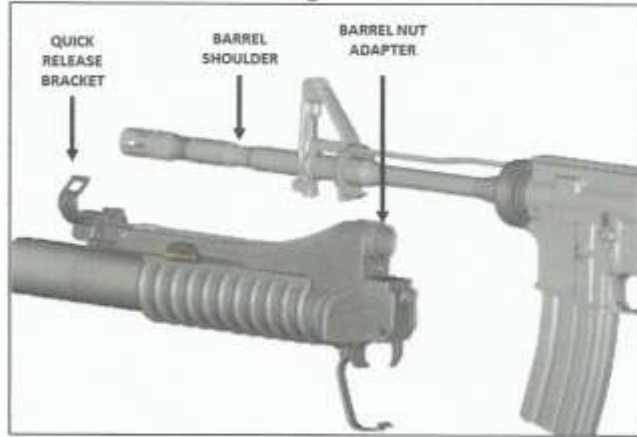

Figure 2



**Conforme:**

\_\_\_\_\_  
Bidder's Company Name

\_\_\_\_\_  
Signature of Authorized Representative

\_\_\_\_\_  
Designation

\_\_\_\_\_  
Date

\_\_\_\_\_  
Date

*[Handwritten Signature]*  
Page 3 of 4

Annex 4-B

By 2028, a world-class Army that is a source of national pride  
Technical Specifications for Launcher, Grenade, 40mm, Under Barrel  
PA SPECS NR FAM - 33(UB) - 08 - 20

PREPARED BY:

  
DARREL P MARIANO  
Major (OS) PA  
Chief, PRB

  
ROXANNE R SANTOS  
Captain (OS) PA  
Chief, FB

RECOMMENDED BY:

  
FLORANTE P SISON  
Colonel MNSA PA  
Chief

APPROVED BY:

  
CIRILITO E SOBEJANA  
Lieutenant General PA  
Commanding General



**Conforme:**

_____
Bidder's Company Name
_____
Signature of Authorized Representative
_____
Designation
_____
Date

Annex 4-C

By 2028, a world-class Army that is a source of national pride.

Test and Acceptance Procedure for Launcher, Grenade, 40mm: Under Barrel  
PA TAP NR FAM – 33(UB) – 04 – 20



HEADQUARTERS  
PHILIPPINE ARMY  
OFFICE OF THE ARMY CHIEF ORDNANCE AND CHEMICAL SERVICE  
Fort Andres Bonifacio, Metro Manila

PA TAP NR FAM – 33(UB)– 04 – 20

SEP 24 2020

**TEST AND ACCEPTANCE PROCEDURE FOR  
LAUNCHER, GRENADE, 40MM: UNDER BARREL**

**1. REFERENCES:**

- 1.1. Technical Specifications for Launcher, Grenade, 40mm: Under Barrel dated \_\_\_\_\_
- 1.2. MIL-L-45935A Military Specification for Launcher, Grenade, 40mm: Detachable, M203 dated 05 September 1974 (reactivated 21 January 2011).
- 1.3. ANSI/ASQ Z1.4-2003: Sampling Procedures and Tables for Inspection by Attributes.

**2. OBJECTIVES:**

- 2.1 To determine the functional reliability of the weapon.
- 2.2 To determine the performance of the weapon when subjected to adverse field and storage conditions.
- 2.3 To determine user safety when weapon is fired in various environmental conditions.
- 2.4 To ascertain compliance to standards and specifications.

**3. GUIDELINES:**

- 3.1 The manufacturer/supplier shall ensure that the complete quantity stated in the contract is packed/palletized prior to the inspection.
- 3.2 Technical inspection and test shall be conducted on the representative samples of the lot through visual/physical, weight and dimensional measurements to determine the over-all workmanship, markings, color and appropriate packaging of the items.
- 3.3 Functional Test will be done to determine the functional performance of the weapon.
- 3.4 Results obtained shall be recorded and evaluated to determine the compliance of the items to technical specifications and as basis for acceptance or rejection of the lot or lots.

**4. PROCEDURES:**

**4.1 COMPLETENESS INSPECTION AND RANDOM SAMPLING:**

The Technical Inspection and Acceptance Committee (TIAC) for Ordnance-Firepower/ Pre-Delivery Inspection (PDI) Team shall check the



Honor. Patriotism. Duty

Page 1 of 8

**Conforme:**

\_\_\_\_\_  
Bidder's Company Name

\_\_\_\_\_  
Signature of Authorized Representative

\_\_\_\_\_  
Designation

\_\_\_\_\_  
Date

Annex 4-C

*By 2028, a world-class Army that is a source of national pride.*  
 Test and Acceptance Procedure for Launcher, Grenade, 40m. Under Barrel  
 PA TAP NR FAM – 33(UB) – 04 – 20

completeness of the goods and conduct random sampling from the lot or lots. The samples shall be properly segregated, packed, marked and secured by the members. (See Para 4.3. – Allocation and Criteria for Representative Samples)

**4.2. TEST AND INSPECTION PARAMETERS:**

**4.2.1. PHYSICAL INSPECTION:**

**4.2.1.1. FOR THE PACKAGING:**

**4.2.1.1.1. Purpose:** This non-destructive test shall be performed to determine the overall workmanship, conformity to technical specifications of the packaging and its markings to ensure that the inspected item shall be free from defects and meet the requirements of the Philippine Army.

**4.2.1.1.2. Procedures:**

**4.2.1.1.2.1.** Visually check the packaging.

**4.2.1.1.2.2.** Inspect the presence and appropriateness of the markings.

**4.2.1.1.2.3.** Inspect for signs of deterioration, condition of handles, loose, missing or incorrect positioned parts.

**4.2.1.1.2.4.** Check for the compliance of the packaging material using appropriate instruments that will precisely identify the composition of the materials. In the absence of facility or equipment, a certification or manufacturing test result shall be provided.

**4.2.1.1.2.5.** Record all observations.

**4.2.1.1.3. Standards:** The packaging shall be free from defects as stated in the **Types and Classifications of Defects- Visual Inspection - Packaging.**

**4.2.1.2. FOR THE LAUNCHER:**

**4.2.1.2.1. Purpose:** This non-destructive test shall be performed to determine the overall workmanship, conformity to technical specifications of the launcher and to ensure that it is free from defect and meet the requirement of the Philippine Army.

**4.2.1.2.2. Procedures:**

**4.2.1.2.2.1.** The sample launcher, its parts or components shall be visually inspected for its compliance on the physical/material technical data requirement using X-Ray Fluorescence (XRF) spectrometers/analyzers or other appropriate instruments that will precisely identify the composition of the materials. In the absence of facility or equipment, a certification or manufacturing test result shall be provided.

**4.2.1.2.2.2.** Inspect for the presence and appropriateness of markings.

**4.2.1.2.2.3.** Each sample shall be examined for presence/ evidence of defect on workmanship.

**4.2.1.2.2.4.** The launcher shall be attached to the standard weapon (as indicated in the weapons application or its equivalent).



Honor. Patriotism. Duty

Page 2 of 8

**Conforme:**

---

Bidder's Company Name

---

Signature of Authorized Representative

---

Designation

---

Date

Annex 4-C

By 2028, a world-class Army that is a source of national pride.  
Test and Acceptance Procedure for Launcher, Grenade, 40m: Under Barrel  
PA TAP NR FAM – 33(LUB) – 04 – 20

4.2.1.2.2.5. Inspect for compatibility and other requirements as indicated in the technical specification.

4.2.1.2.2.6. Record all observations.

4.2.1.2.3. Standard: The launcher shall be free from defects as stated in the Types and Classifications of Defects- Physical Inspection- Launchers.

4.2.2. WEIGHT AND DIMENSIONAL INSPECTION:

4.2.2.1. Purpose: This test shall be performed to determine compliance of the launcher to the provided weight and dimensional requirement in the technical specifications of the Philippine Army.

4.2.2.2. Procedures:

4.2.2.2.1. The sample launcher, its parts or components shall be measured by using a weighing scale, go and no-go gages, vernier caliper, micrometer caliper or other appropriate measuring instruments.

4.2.2.2.2. Record the weight and dimensions.

4.2.2.3. Standard: The launcher shall be free from defects as stated in the Types and Classifications of Defects- Weight and Dimensional Inspection.

4.2.3. PERFORMANCE TESTS:

A series of tests shall be performed to ensure that the launcher will efficiently function and perform accordingly based on the established standards and specifications when subjected to various methods of actuation simulating field usage and storage conditions.

4.2.3.1. TRIGGER PULL TEST:

4.2.3.1.1. Purpose: This test shall be performed to determine conformity of the trigger pull of the launcher as required in the technical specifications.

4.2.3.1.2. Procedure:

4.2.3.1.2.1. Measure the trigger pull using force gauge or any equivalent.

4.2.3.1.2.2. Observe for creep or any irregular trigger behavior by manually pulling the trigger.

4.2.3.1.2.3. Record observations.

4.2.3.1.3. Standard: Trigger pull shall be according to specification.

4.2.3.2. RATE OF FIRE TEST:

4.2.3.2.1. Purpose: This test shall be performed to determine conformity of the launcher's rate of fire.



Honor. Patriotism. Duty

Page 3 of 8

Conforme:
Bidder's Company Name
Signature of Authorized Representative
Designation
Date

Annex 4-C

By 2028, a world-class Army that is a source of national pride.  
Test and Acceptance Procedure for Launcher, Grenade, 40m, Under Barrel  
PA TAP NR FAM - 33(UB) - 04 - 20

4.2.3.2.2. Procedures:

4.2.3.2.2.1. The launcher shall be attached to a standard weapon (as indicated in the weapons application or its equivalent).

4.2.3.2.2.2. Using appropriate type of ammunition, the handheld weapon shall be fired as many rounds as possible for a duration of one minute.

4.2.3.2.2.3. Repeat three (3) times and note the average.

4.2.3.2.3. Standard:

4.2.3.2.3.1. The average rate of fire of the launcher shall be within the specification.

4.2.3.2.3.2. The launcher shall be free from defects as stated in the **Types and Classifications of Defects - Functional Defects.**

4.2.3.3. TARGETING AND ACCURACY TEST:

4.2.3.3.1. Purpose: This test shall be performed to determine conformity of the accuracy of the launcher when fired at 200 meters.

4.2.3.3.2. Procedures:

4.2.3.3.2.1. The launcher shall be attached to a standard weapon (as indicated in the weapons application or its equivalent). Top edge of the front sight post flange of the rifle shall be set flush with or not more than .030 inch below the bottom surface of the of the front sight slot. The leaf sight shall be unfolded to the sighting position. No adjustment of the leaf sight shall be made after it has been set in the leaf sight alignment.

4.2.3.3.2.2. On benchrest position and by using appropriate type of ammunition, 20 rounds shall be fired to the target at a distance of 200 meters.

4.2.3.3.2.3. The range and deflection of each round shall be recorded.

4.2.3.3.2.4. Compute for standard deviation (range and deflection), probable error and center of impact of the 20-round group.

4.2.3.3.2.5. Wind condition during the firing shall not exceed 10 miles per hour.

4.2.3.3.3. Standard:

4.2.3.3.3.1. Targeting and accuracy of the launcher shall be according to the specification.

4.2.3.3.3.2. The launcher shall be free from defects as stated in the **Types and Classifications of Defects- Functional Defects.**

4.2.3.4. MAXIMUM RANGE TEST:

4.2.3.4.1. Purpose: This test shall be performed to determine conformity of the maximum range of the launcher as required in the specifications.



Honor. Patriotism. Duty

Page 4 of 8

Conforme:
Bidder's Company Name
Signature of Authorized Representative
Designation
Date

Annex 4-C

By 2028, a world-class Army that is a source of national pride.  
Test and Acceptance Procedure for Launcher, Grenade, 40m: Under Barrel  
PA TAP NR FAM – 33(UB) – 04 – 20

4.2.3.4.2. Procedures:

4.2.3.4.2.1. The launcher shall be attached to the standard weapon (as indicated in the weapons application or its equivalent).

4.2.3.4.2.2. Conduct any applicable or appropriate testing procedure that will properly identify the maximum range of the launcher shall be conducted.

4.2.3.4.2.3. Record observations

4.2.3.4.3. Standard:

4.2.3.4.3.1. Maximum Range of the launcher shall be according to specification.

4.2.3.4.3.2. The launcher shall be free from defects as stated in the **Types and Classifications of Defects- Functional Defects.**

4.2.3.5. DROP SAFETY TEST:

4.2.3.5.1. Purpose: To determine durability and whether the launcher will fire upon impact when dropped.

4.2.3.5.2. Procedures:

4.2.3.5.2.1. The launcher shall be attached to the standard weapon (as indicated in the weapons application or its equivalent).

4.2.3.5.2.2. Conduct any applicable or appropriate testing procedure that will properly determine safety of the launcher when dropped from a height of 1.3 meters.

4.2.3.5.2.3. Inspect the weapon and ascertain the position of the safety switch and check to see if the launcher has fired.

4.2.3.5.2.4. Conduct firing test if the serviceability of the launcher is questionable.

4.2.3.5.2.5. Record observations.

4.2.3.5.3. Standard: Performance of the launcher shall be according to specification.

4.2.3.6. INTERCHANGEABILITY TEST:

4.2.3.6.1. Purpose: To determine the interchangeability of the parts of the launcher.

4.2.3.6.2. Procedures:

4.2.3.6.2.1. Launcher shall be tested for interchangeability of parts by disassembling the launcher and interchanging the parts using appropriate procedures.

4.2.3.6.2.2. The launcher shall be re-assembled and shall be tested for trigger pull and functional firing of two (2) rounds per launcher.

4.2.3.6.3. Standard:

4.2.3.6.3.1. Performance of launcher shall be according to specification.

4.2.3.6.3.2. The launcher shall be free from defects as stated in the **Types and Classifications of Defects- Functional Defects.**



Honor. Patriotism. Duty

Page 5 of 8

Conforme:  
\_\_\_\_\_  
Bidder's Company Name  
\_\_\_\_\_  
Signature of Authorized Representative  
\_\_\_\_\_  
Designation  
\_\_\_\_\_  
Date



Annex 4-C

By 2028, a world-class Army that is a source of national pride.  
 Test and Acceptance Procedure for Launcher, Grenade, 40m: Under Barrel  
 PA TAP NR FAM – 33(LIB) – 04 – 20

**4.2.3.7. FUNCTIONAL TEST:**

**4.2.3.7.1. Purpose:** To determine if the launcher can withstand firing of 72 rounds without malfunction and damage.

**4.2.3.7.2. Procedures:**

**4.2.3.7.2.1.** The launcher cleaned and lightly oiled shall be attached to the standard weapon (as indicated in the weapons application) and set on a rifle rest.

**4.2.3.7.2.2.** Set the fire selector to Safe position then pull the trigger to check whether the launcher will fire or not

**4.2.3.7.2.3.** Using appropriate type of round, a four (4) 18-round series shall be fired from the launcher. Each series shall be fired within 4 minutes including reloading time.

**4.2.3.7.2.4.** Conduct visual, gauging and crack inspection as applicable to determine damage on the launcher after each series.

**4.2.3.7.2.5.** Record observation.

**4.2.3.7.2.6.** A 15-minute cooling period and preparation is allowed between each series.

**4.2.3.7.3. Standard:** Performance of the launcher shall be according to specification.

*Note: During the test, the proponent is allowed to clean the launcher after each test/functional firing in preparation for the next test. However, cleaning shall be done in the presence of test team members.*

**4.2. ALLOCATION AND CRITERIA FOR REPRESENTATIVE SAMPLES:**  
 (Based on the attached Sampling Plans for launcher).

TYPE OF INSPECTION/ TEST	NR OF SAMPLES	CRITERIA
<b>A. Physical Inspection:</b>		
1. For the Packaging	100% of the Quantity of samples indicated in Table 1 corresponding to the total number of packaging for lot size.	Sampling Plan for Test and Acceptance of Firearms - Small Arms – Cal .22 up to 30mm and Launchers (Attached)
2. For the Launchers	100% of the Quantity of samples indicated in Table 1 corresponding to the lot size.	Sampling Plan for Test and Acceptance of Firearms - Small Arms – Cal .22 up to 30mm and Launchers
<b>Weight and Dimensional Inspection:</b>		
3. Overall Weight 4. Overall Length 5. Barrel Length	100% of the quantity of samples indicated in Table 1 corresponding to the total number of lot size.	Sampling Plan for Test and Acceptance of Firearms - Small Arms – Cal .22 up to 30mm and Launchers
<b>B. Performance Tests: (Samples to undergo the test shall be taken from the representative samples that passed the Physical Inspection)</b>		
1. Trigger Pull Test	100% of the quantity of samples indicated in Table 2 corresponding to the total number of lot size.	Sampling Plan for Test and Acceptance of Firearms - Small Arms – Cal .22 up to 30mm and Launchers
2. Rate of Fire Test	1 Launcher	Note 1
3. Targeting and Accuracy Test	1 Launcher	Note 1



Honor, Patriotism, Duty

Page 6 of 8

**Conforme:**

\_\_\_\_\_

Bidder's Company Name

\_\_\_\_\_

Signature of Authorized Representative

\_\_\_\_\_

Designation

\_\_\_\_\_

Date

Annex 4-C

By 2028, a world-class Army that is a source of national pride.

Test and Acceptance Procedure for Launcher, Grenade, 40mm, Under Barrel  
PA TAP NR FAM – 33(UB) – 04 – 20

4. Maximum Range Test	1 Launcher	Note 1
5. Drop Safety Test	1 Launcher	Note 1
6. Interchangeability Test	4 Launcher	Note 2
7. Functional Test	1 Launcher	Note 1
<b>C. Other Requirement:</b>		
Certificate	-	Note 3

**Notes:**

- 1 – Failure of the sample to comply with the applicable requirement/s shall cause for the failure of test and rejection of the lot.
- 2 – Failure of any sample to comply with the applicable requirement/s shall cause for the failure of test subject to testing of a second sample. If any sample fails from the second test, the lot shall be rejected.
- 3 – Failure of the manufacturer to provide the requirement shall cause for the rejection of the lot.

**5. TYPES AND CLASSIFICATIONS OF DEFECTS:**

TYPES OF DEFECTS	CLASSIFICATION OF DEFECTS		
	CRIT	MAJ	MIN
<b>A. Physical Inspection:</b>			
<b>For the Packaging:</b>			
- Type or material not according to specifications		X	
- Number of item/s per packaging requirement not according to specification		X	
- Damaged, missing and incorrectly positioned parts			X
- Incorrect, missing, or illegible marking			X
- Evidence of poor workmanship			X
<b>For the Launcher:</b>			
- Caliber not according to specification		X	
- Not compatible with ammunition indicated in the specification		X	
- Scratches, burrs, and dents affecting the serviceability of launcher		X	
- Scratches, burrs, and dents not affecting the serviceability of launcher		X	
- Damaged or missing part		X	
- Incorrect, missing, or illegible marking		X	
<b>Barrel</b>			
- Barrel material composition not according to specification		X	
- Barrel rifling twist not according to specification		X	
- Barrel finish/color not according to specification		X	
<b>Sight</b>			
- Not provided with leaf sight		X	
- Elevation adjustment increment not according to specification		X	
<b>Operating Systems</b>			
- Firing modes not according to specification		X	
- Attachment to assault rifle not according to specification		X	
- GL cannot be rigidly attached to the rifle		X	
- Quick release Bracket Mounting not provided or not compatible with M4A1 type barrel		X	
- Quick release Bracket Mounting not provided		X	
- Type of loading not according to specification		X	



Honor. Patriotism. Duty

Page 7 of 8

**Conforme:**

\_\_\_\_\_

Bidder's Company Name

\_\_\_\_\_

Signature of Authorized Representative

\_\_\_\_\_

Designation

\_\_\_\_\_

Date

Annex 4-C

By 2028, a world-class Army that is a source of national pride.

Test and Acceptance Procedure for Launcher, Grenade, 40mm: Under Barrel  
PA TAP NR FAM – 33(UB) – 04 – 20

<b>Accessories</b>			
- Accessory not according to specification			X
- Damaged or missing accessory			X
<b>B. Weight and Dimensional Inspection:</b>			
- Overall weight not within specification		X	
- Overall length not within specification		X	
- Barrel Length not within specification		X	
<b>C. Performance Defects:</b>			
- Trigger pull not free from creep		X	
- Trigger pull not within the specification		X	
<b>Functional Defects</b>			
- Launcher fired while on safe mode	X		
- Rupture of the launcher during firing	X		
- Evidence of injurious defect after firing		X	
- Any other damage/defect that affect the function of the launcher		X	
- Any other damage/defect that do not affect the function of the launcher			X

**3. ACCEPTANCE AND REJECTION:**

Acceptability of lot/s shall be determined by using the Acceptance Quality Limit (AQL) indicated in the Acceptance Criteria Tables for Physical Inspection and Performance Test based on ANZI/ASQ Z1.4-2003: Sampling Procedures and Tables for Inspection by Attributes/MIL-STD 105E: Sampling Procedures and Tables for Inspection by Attributes dated 10 May 1989.

**4. RESULT:**

The result of the test based on the above criteria shall be the basis of the Philippine Army Technical Inspection and Acceptance Committee (PA-TIAC) for Ordnance-Firepower/Pre-Delivery Inspection (PDI) Team in the acceptance or rejection of the goods/items.

**PREPARED BY:**

  
**DARREL P MARIANO**  
 Major (OS) PA  
 Chief, PRB

  
**ROXANNE R SANTOS**  
 Captain (OS) PA  
 Chief, FB

**APPROVED BY:**

  
**FLORANTE P SISON**  
 Colonel, MNSA PA  
 Chief



Honor. Patriotism. Duty.

**Conforme:**

\_\_\_\_\_  
 Bidder's Company Name

\_\_\_\_\_  
 Signature of Authorized Representative

\_\_\_\_\_  
 Designation

\_\_\_\_\_  
 Date

Annex 4-C

By 2028, a world-class Army that is a source of national pride.

SAMPLING PLAN FOR THE TEST AND ACCEPTANCE OF FIREARMS  
(For Small Arms - Cal .22 up to 30mm and Launchers)



HEADQUARTERS  
PHILIPPINE ARMY  
OFFICE OF THE ARMY CHIEF ORDNANCE AND CHEMICAL SERVICE  
Fort Andres Bonifacio, Metro Manila

SEP 24 2020

**SAMPLING PLANS FOR THE TEST AND ACCEPTANCE OF FIREARMS**  
(For Small Arms – Cal .22 up to 30mm and Launchers)

**I. REFERENCES:**

- a. ANZI/ASQ Z1.4-2003: Sampling Procedures and Tables for Inspection by Attributes.
- b. Military Standard 105E dtd 10 May 89, Subject: Sampling Procedures and Tables for Inspection by Attributes.

**II. ACCEPTANCE AND REJECTION:**

Acceptability of lot/s shall be determined by using the Acceptance Quality Limit (AQL) indicated in the following Sampling Plan Tables for Visual Inspection, Dimensional Inspection, Performance Test, and Functional Test.

If the number of defects found in the first sample is equal to or less than the first **Acceptance (Ac)** number, the lot or batch shall be accepted. If the number of defects found in the first sample is equal to or greater than the first **Rejection (Re)** number, the lot or batch shall be rejected.

If the number of defects found in the first sample is between the first **Acceptance (Ac)** and **Rejection (Re)** numbers, second samples shall be inspected. The number of defects found in the first and second samples shall be accumulated. If the cumulative number of defects is equal to or less than the second acceptance number, the lot or batch shall be accepted. If the cumulative number of defects is equal to or greater than the second rejection number, the lot or batch shall be rejected.

**A. For Physical Inspection of Firearms and Packaging:** Double Sampling Plan for Normal Inspection of General Inspection Level II

Table 1

Lot Size	Sample Size Code	Sampling	Nr of Samples	Classification of Defects (AQL)			
				Major (2.5)		Minor (4.0)	
				Ac	Re	Ac	Re
2 - 8	A	1	2	0	1	0	1
		2	-	-	-	-	-
9 - 15	B	1	2	0	1	0	1
		2	-	-	-	-	-



Honor. Patriotism. Duty

Page 1 of 3

**Conforme:**

\_\_\_\_\_  
Bidder's Company Name

\_\_\_\_\_  
Signature of Authorized Representative

\_\_\_\_\_  
Designation

\_\_\_\_\_  
Date

Annex 4-C

By 2028, a world-class Army that is a source of national pride.

SAMPLING PLAN FOR THE TEST AND ACCEPTANCE OF FIREARMS  
(For Small Arms - Cal. 22 up to 30mm and Launchers)

16 - 25	C	1	3	0	1	0	1
		2	-	-	-	-	-
26 - 50	D	1	5	0	1	0	2
		2	5	-	-	1	2
51 - 90	E	1	8	0	2	0	2
		2	8	1	2	1	2
91 - 150	F	1	13	0	2	0	3
		2	13	1	2	3	4
151 - 280	G	1	20	0	3	1	4
		2	20	3	4	4	5
281 - 500	H	1	32	1	4	2	5
		2	32	4	5	6	7
501 - 1,200	J	1	50	2	5	3	7
		2	50	6	7	8	9
1,201 - 3,200	K	1	80	3	7	5	9
		2	80	8	9	12	13
3,201 - 10,000	L	1	125	5	9	7	11
		2	125	12	13	18	19
10,001 - 35000	M	1	200	7	11	11	16
		2	200	18	19	26	27
35,001 - 150,000	N	1	315	11	16	11	16
		2	315	26	27	26	27
150,001 - 500,000	P	1	500	11	16	11	16
		2	500	26	27	26	27
500,001 and over	Q	1	800	11	16	11	16
		2	800	26	27	26	27

B. For Performance and Functional Tests of Firearms: Double Sampling Plan for Normal Inspection of Special Inspection Level S3

Table 2

Lot Size	Sample Size Code	Sampling	Nr of Samples	Classification of Defects (AQL)					
				Critical (1.0)		Major (2.5)		Minor (6.5)	
				Ac	Re	Ac	Re	Ac	Re
2 - 15	A	1	2	0	1	0	1	0	1
		2	-	-	-	-	-	-	-
16 - 50	B	1	2	0	1	0	1	0	1
		2	-	-	-	-	-	-	-
51 - 150	C	1	3	0	1	0	1	0	2
		2	-	-	-	-	-	1	2
151 - 500	D	1	5	0	1	0	1	0	2
		2	5	-	-	-	-	1	2
501 - 3,200	E	1	8	0	1	0	2	0	3
		2	8	-	-	1	2	3	4



Honor. Patriotism. Duty.

*[Signature]*  
Page 2 of 3

**Conforme:**

\_\_\_\_\_

Bidder's Company Name

\_\_\_\_\_

Signature of Authorized Representative

\_\_\_\_\_

Designation

\_\_\_\_\_

Date

Annex 4-C

By 2028, a world-class Army that is a source of national pride.

SAMPLING PLAN FOR THE TEST AND ACCEPTANCE OF FIREARMS  
(For Small Arms - Cal. 22 up to 30mm and Launchers)

3,201 – 35,000	F	1	13	0	1	0	2	1	4
		2	13	-	-	1	2	4	5
35,001 – 500,000	G	1	20	0	2	0	3	2	5
		2	20	1	2	3	4	6	7
500,001 and over	H	1	32	0	2	1	4	3	7
		2	32	1	2	4	5	8	9

III. RESULT:

The result of the test based on the above criteria shall be the basis of the Philippine Army Technical Inspection and Acceptance Committee (PA-TIAC) for Ordnance-Firepower/Pre-Delivery Inspection (PDI) Team in the acceptance or rejection of the goods/items.

PREPARED BY:

  
**DARREL P. MARIANO**  
 Major, (OS) PA  
 Chief, PRB

APPROVED BY:

  
**FLORANTE P. SISON**  
 Colonel, MNSA PA  
 Chief



Honor. Patriotism. Duty.



**Conforme:**

\_\_\_\_\_  
 Bidder's Company Name

\_\_\_\_\_  
 Signature of Authorized Representative

\_\_\_\_\_  
 Designation

\_\_\_\_\_  
 Date

Annex 4-C

By 2028, a world-class Army that is a source of national pride.

HEADQUARTERS  
PHILIPPINE ARMY  
OFFICE OF THE ARMY CHIEF ORDNANCE AND CHEMICAL SERVICE  
Fort Andres Bonifacio, Metro Manila

**SAMPLE DIAGRAM FOR MARKINGS ON PACKAGING OF  
FIREARMS**

**INNER PACKAGING:** (Sample Illustration, Diagram Not in Scale)

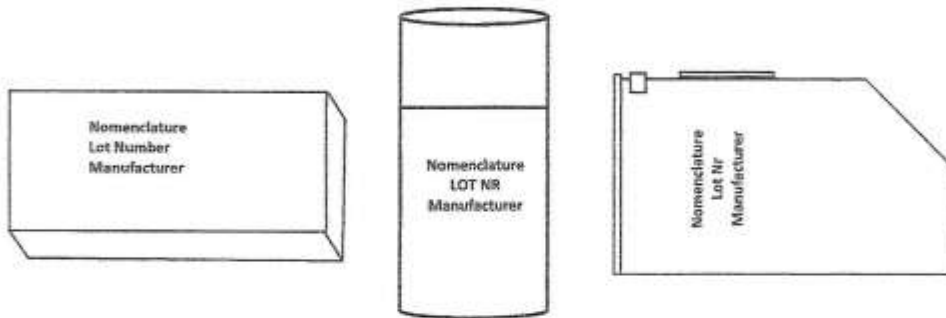

**INTERMEDIATE PACKAGING:** (Sample Illustration, Diagram Not in Scale)

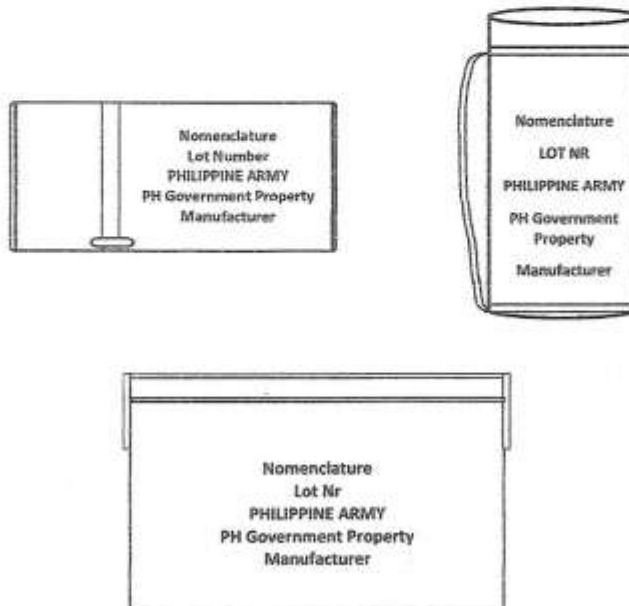

**Conforme:**

\_\_\_\_\_  
Bidder's Company Name

\_\_\_\_\_  
Signature of Authorized Representative

\_\_\_\_\_  
Designation

\_\_\_\_\_  
Date



Annex 4-C

By 2028, a world-class Army that is a source of national pride.

**OUTER PACKAGING:** (Sample Illustration, Diagram Not in Scale)

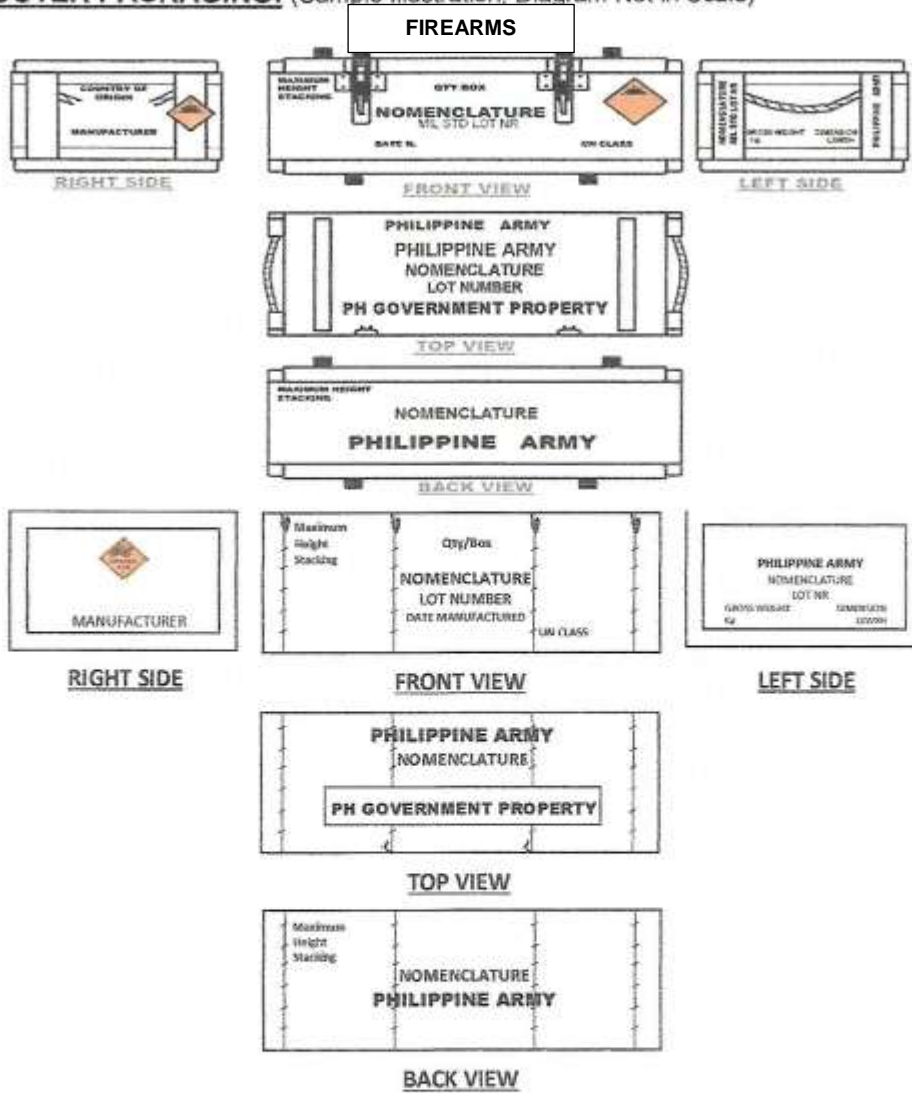

**Note:** The illustrated diagram is just an example purposely to serve as reference. Placement, font size, and font style are manufacturer's standard. Refer to Technical Specification for the minimum required markings.

PREPARED BY:

APPROVED BY:

*[Signature]*  
 DARREL P MARIANO  
 MAJ (OS) PA  
 Chief, PRB

*[Signature]*  
 FLORENTE P SISON  
 Colonel MNSA PA  
 Chief

**Conforme:**

\_\_\_\_\_  
 Bidder's Company Name

\_\_\_\_\_  
 Signature of Authorized Representative

\_\_\_\_\_  
 Designation

\_\_\_\_\_  
 Date





Annex 5

**TECHNICAL BID FORM****PROCUREMENT OF GRENADE LAUNCHER, 40MM  
FOR THE PHILIPPINE ARMY****BID REF NO. ORD PABAC 027-20****MANUFACTURER'S CERTIFICATION ON CONFORMANCE TO THE PROJECTS  
TECHNICAL SPECIFICATIONS, PACKAGING, MARKINGS, TEST AND  
ACCEPTANCE PROCEDURES AND SAMPLING PLAN**

I, \_\_\_\_\_, Production Engineer/Technical Personnel of \_\_\_\_\_ (Name of Foreign Company/Bidder) hereby certify that I have read and understood each and every page of the Technical Specifications, Test and Acceptance Procedures and its Sampling Plan and AQL, Markings, and Packaging for the project, Procurement of \_\_\_\_\_ for Philippine Army under Bid Ref Nr \_\_\_\_\_ copies of which we have acknowledged to have received on \_\_\_\_\_.

I/WE understand that having issued this Certification, we conform to the requirements of the above-stated Project as detailed in the Technical Specifications and other Technical documents and that, in the event that the Contract for the Project is awarded to us, we certify to complete and accomplish our obligations in accordance with, the term and conditions of the said project. This Certification is part of our Technical Bid for the above-mentioned project.

I/WE are executing this Certification to attest to the truth of the foregoing fact/s.

\_\_\_\_\_  
Name

\_\_\_\_\_  
Signature

**PRODUCTION ENGINEER/ TECHNICAL PERSONNEL**  
Position in the Company

\_\_\_\_\_  
Date

## Annex 6

**TECHNICAL BID FORM****PROCUREMENT OF GRENADE LAUNCHER, 40MM  
FOR THE PHILIPPINE ARMY****BID REF NO. ORD PABAC 027-20*****Section VI. Schedule of Requirements***

The delivery schedule expressed as weeks/months stipulates hereafter a delivery date which is the date of delivery to the project site.

<b>Lot</b>	<b>Description</b>	<b>Qty</b>	<b>Unit</b>	<b>Delivery Period</b>
1	Grenade Launcher, 40mm	1,024	units	<b>One Hundred Eighty (180) Calendar Days upon receipt of NTP</b> by the supplier, which date shall not be later than seven (7) calendar days from the issuance of NTP; should the supplier fail to comply, the delivery period shall commence.
2	Cut-away, Grenade Launcher, 40mm	5	units	
3	Tools for installation and basic maintenance	1,024	sets	
4	Cleaning Paraphernalia (minimum) <ul style="list-style-type: none"> <li>- Bore Brush with Cleaning Rod or Pull Cord for Breech to Muzzle Cleaning</li> <li>- Parts Brush</li> <li>- Gun Oil (25ml)</li> <li>- Case or Pouch for the cleaning paraphernalia</li> </ul>	1,024	sets	
5	User or Operator's Manual that shall include the following: <ul style="list-style-type: none"> <li>- Description and Theory of Operation</li> <li>- Operator Instructions</li> <li>- Troubleshooting Procedures</li> <li>- Maintenance Instructions</li> <li>- Additional Supporting Information</li> </ul>	1,024	pcs	

6	Technical Manual that shall include the following: <ul style="list-style-type: none"> <li>- Basic Issue Items List</li> <li>- Repair Parts</li> <li>- Special Tools List</li> <li>- Technical Data/Specifications of the weapon</li> </ul>	50	pcs	
7	Armorer's Tool Kit (minimum) <ul style="list-style-type: none"> <li>- Hammer (Ball Peen) 10oz</li> <li>- Hammer (Dead Blow) Rubber 5oz</li> <li>- Bench Block (Mechanical)</li> <li>- Hex Key Set (Allen) 0.05in–3/8in</li> <li>- File Set Tools</li> <li>- Screw Driver (Flat Tip)</li> <li>- Screw Driver (Cross Tip)</li> <li>- Roll Pin Punch Set</li> <li>- Punch Drive Pin Set</li> <li>- Brass Drift Pin 3/8 in (6 in length)</li> <li>- Armorer's Tool Kit Casing</li> </ul>	20	sets	
8	In-country Training: <ul style="list-style-type: none"> <li>- Operation and Maintenance Training</li> </ul>	47	pax	

\_\_\_\_\_  
Name of Company (in print)

\_\_\_\_\_  
Signature of Company Authorized Representative

\_\_\_\_\_  
Name and Designation

\_\_\_\_\_  
Date

---

## Omnibus Sworn Statement

---

REPUBLIC OF THE PHILIPPINES        )  
CITY/MUNICIPALITY OF \_\_\_\_\_) S.S.

### AFFIDAVIT

I, [Name of Affiant], of legal age, [Civil Status], [Nationality], and residing at [Address of Affiant], after having been duly sworn in accordance with law, do hereby depose and state that:

1. **Select one, delete the other:**

*If a sole proprietorship:* I am the sole proprietor or authorized representative of [Name of Bidder] with office address at [address of Bidder];

*If a partnership, corporation, cooperative, or joint venture:* I am the duly authorized and designated representative of [Name of Bidder] with office address at [address of Bidder];

2. **Select one, delete the other:**

*If a sole proprietorship:* As the owner and sole proprietor, or authorized representative of [Name of Bidder], I have full power and authority to do, execute and perform any and all acts necessary to participate, submit the bid, and to sign and execute the ensuing contract for [Name of the Project] of the [Name of the Procuring Entity], as shown in the attached duly notarized Special Power of Attorney;

*If a partnership, corporation, cooperative, or joint venture:* I am granted full power and authority to do, execute and perform any and all acts necessary to participate, submit the bid, and to sign and execute the ensuing contract for [Name of the Project] of the [Name of the Procuring Entity], as shown in the attached [state title of attached document showing proof of authorization (e.g., duly notarized Secretary's Certificate, Board/Partnership Resolution, or Special Power of Attorney, whichever is applicable;)];

3. [Name of Bidder] is not "blacklisted" or barred from bidding by the Government of the Philippines or any of its agencies, offices, corporations, or Local Government Units, foreign government/foreign or international financing institution whose blacklisting rules have been recognized by the Government Procurement Policy Board;

4. Each of the documents submitted in satisfaction of the bidding requirements is an authentic copy of the original, complete, and all statements and information provided therein are true and correct;

5. *[Name of Bidder]* is authorizing the Head of the Procuring Entity or its duly authorized representative(s) to verify all the documents submitted;

6. **Select one, delete the rest:**

*If a sole proprietorship:* The owner or sole proprietor is not related to the Head of the Procuring Entity, members of the Bids and Awards Committee (BAC), the Technical Working Group, and the BAC Secretariat, the head of the Project Management Office or the end-user unit, and the project consultants by consanguinity or affinity up to the third civil degree;

*If a partnership or cooperative:* None of the officers and members of *[Name of Bidder]* is related to the Head of the Procuring Entity, members of the Bids and Awards Committee (BAC), the Technical Working Group, and the BAC Secretariat, the head of the Project Management Office or the end-user unit, and the project consultants by consanguinity or affinity up to the third civil degree;

*If a corporation or joint venture:* None of the officers, directors, and controlling stockholders of *[Name of Bidder]* is related to the Head of the Procuring Entity, members of the Bids and Awards Committee (BAC), the Technical Working Group, and the BAC Secretariat, the head of the Project Management Office or the end-user unit, and the project consultants by consanguinity or affinity up to the third civil degree;

7. *[Name of Bidder]* complies with existing labor laws and standards; and
8. *[Name of Bidder]* is aware of and has undertaken the following responsibilities as a Bidder:
  - a) Carefully examine all of the Bidding Documents;
  - b) Acknowledge all conditions, local or otherwise, affecting the implementation of the Contract;
  - c) Made an estimate of the facilities available and needed for the contract to be bid, if any; and
  - d) Inquire or secure Supplemental/Bid Bulletin(s) issued for the *[Name of the Project]*.
9. *[Name of Bidder]* did not give or pay directly or indirectly, any commission, amount, fee, or any form of consideration, pecuniary or otherwise, to any person or official, personnel or representative of the government in relation to any procurement project or activity.

IN WITNESS WHEREOF, I have hereunto set my hand this \_\_\_ day of \_\_\_, 20\_\_\_ at \_\_\_\_\_, Philippines.

\_\_\_\_\_  
Bidder’s Representative/Authorized Signatory

**SUBSCRIBED AND SWORN** to before me this \_\_\_ day of *[month]* *[year]* at *[place of execution]*, Philippines. Affiant/s is/are personally known to me and was/were identified by me through competent evidence of identity as defined in the 2004 Rules on Notarial Practice (A.M. No. 02-8-13-SC). Affiant/s exhibited to me his/her *[insert type of government identification card used]*, with his/her photograph and signature appearing thereon, with no. \_\_\_\_\_ and his/her Community Tax Certificate No. \_\_\_\_\_ issued on \_\_\_ at \_\_\_\_\_.

Witness my hand and seal this \_\_\_ day of *[month]* *[year]*.

**NAME OF NOTARY PUBLIC**

Serial No. of Commission \_\_\_\_\_  
Notary Public for \_\_\_\_\_ until \_\_\_\_\_  
Roll of Attorneys No. \_\_\_\_\_  
PTR No. \_\_\_\_\_ *[date issued]*, *[place issued]*  
IBP No. \_\_\_\_\_ *[date issued]*, *[place issued]*

Doc No: \_\_\_\_\_  
Page No: \_\_\_\_\_  
Book No: \_\_\_\_\_  
Series of: \_\_\_\_\_

\* This form will not apply for WB funded projects.

(Bidder's Company Letterhead)

## **WARRANTY UNDERTAKING**

**PROCUREMENT OF GRENADE LAUNCHER, 40MM  
FOR THE PHILIPPINE ARMY**

**BID REF NO. ORD PABAC 027-20**

I/We, (Name), (Title/Capacity), the duly authorized representative of (Company/Bidder), hereby commits that should we be awarded the contract, we will issue a Warranty Certificate in favor of the Philippine Army (PA) valid for at least one (1) year from date of final acceptance.

This Undertaking shall form part of the Technical Requirements for the aforesaid procurement project

\_\_\_\_\_  
Signature of Company Representative

\_\_\_\_\_  
Name & Designation

\_\_\_\_\_  
Date

**Bidder's Company Letterhead**

**PROCUREMENT OF GRENADE LAUNCHER, 40MM  
FOR THE PHILIPPINE ARMY**

**BID REF NO. ORD PABAC 027-20**

**CERTIFICATE OF NET FINANCIAL CONTRACTING CAPACITY  
(PLS SHOW FIGURES AT HOW YOU ARRIVED AT THE NFCC)**

This is to certify that our Net Financial Contracting Capacity (NFCC) is **Philippine Pesos** \_\_\_\_\_ (**PhP** \_\_\_\_\_) which is at least equal to the total ceiling price we are bidding. The amount is computed as follows;

CA	=	Current Assets	PhP
Less:			-
CL	=	Current Liabilities	_____
		<b>Sub-total 1</b>	PhP
			X 15
		<b>Sub-total 2</b>	PhP
Less:			-
C	=	Value of all outstanding or uncompleted portions of the projects under on-going contracts, including awarded contracts yet to be started coinciding with the contract for this project.	PhP
<b>NFCC</b>			<b>PhP</b>

Issued this \_\_\_\_\_ day of \_\_\_\_\_, 20\_\_\_\_\_.

**CERTIFIED CORRECT:**

\_\_\_\_\_  
Name and Signature of Authorized Representative

\_\_\_\_\_  
Position

\_\_\_\_\_  
Date



**(NAME OF BANK)**  
**COMMITTED LINE OF CREDIT**

Date: \_\_\_\_\_

Philippine Army Bids and Awards Committee  
Fort Andres Bonifacio, Metro Manila

CONTRACT/PROJECT : \_\_\_\_\_  
COMPANY FIRM : \_\_\_\_\_  
ADDRESS : \_\_\_\_\_  
BANK/FINANCING INSTITUTION : \_\_\_\_\_  
ADDRESS : \_\_\_\_\_  
AMOUNT : \_\_\_\_\_

This is to certify that the above Bank/Financing Institution with Business address indicated above, commits to provide the (Supplier/Distributor/Manufacturer/Contractor), if awarded the above-mentioned Contract, a credit line in the amount specified above which shall be exclusively used to finance the performance of the above-mentioned contract subject to the terms, conditions and requirements.

The credit line shall be available within fifteen (15) calendar days after receipt by the Supplier/Distributor/Manufacturer/Contractor of the Notice of Award and such line of credit shall be maintained until issuance of the Certificate of Acceptance.

This Certification is being issued in favor of said (Supplier/Distributor/Manufacturer/Contractor) in connection with the bidding requirement of (Name of Procuring Entity) for the above-mentioned Contract. We are aware that any false statement issued by us make us liable for perjury.

This Committed line of credit cannot be terminated or cancelled without the prior written approval of the Philippine Army.

\_\_\_\_\_  
Name and Signature of Authorized Financing Institution Office

\_\_\_\_\_  
Official Designation

Concurred by:

\_\_\_\_\_  
Name and Signature of Supplier/Distributor/Manufacturer/Contractor authorized representative

\_\_\_\_\_  
Official Designation

SUBSCRIBED AND SWORN TO BEFORE ME this \_\_\_\_\_ day of \_\_\_\_\_ at \_\_\_\_\_, Philippines. Affiant exhibited to me his/her competent Evidence of identity (as defined by the 2004 Rules on Notarial Practice \_\_\_\_\_ issued \_\_\_\_\_ at \_\_\_\_\_, Philippines.

Doc No: \_\_\_\_\_  
Page No: \_\_\_\_\_  
Book No: \_\_\_\_\_  
Series of: \_\_\_\_\_

NOTARY PUBLIC

**Amount should be machine validated**

**Annex 11-A**

**PROTOCOL/UNDERTAKING OF AGREEMENT TO ENTER INTO JOINT VENTURE**

This **PROTOCOL/UNDERTAKING OF AGREEMENT TO ENTER INTO JOINT VENTURE** executed by: \_\_\_\_\_, A sole proprietorship/corporation duly organized and existing under and by virtue of the laws of the Philippines, with offices located at \_\_\_\_\_, represented herein by its \_\_\_\_\_, hereinafter referred to as \_\_\_\_\_.,

-and-

\_\_\_\_\_ A sole proprietorship/corporation duly organized and existing under and by virtue of the laws of the Philippines, with offices located at \_\_\_\_\_, represented herein by its \_\_\_\_\_, hereinafter referred to as \_\_\_\_\_.,

For submission to the **Philippine Army Bids and Awards Committee (PABAC)**, pursuant to Section 23.1 (b) of the Revised Implementing Rules and Regulations (IRR) of Republic Act (RA) No 9184.

**WITNESSETH That:**

WHEREAS, the parties desire to participate as a joint venture in the public bidding that will be conducted by the PABAC pursuant to Republic Act (RA) No 9184 and its Revised Implementing Rules and Regulations (IRR) with the following particulars:

Bid Reference No.	
Name/Title of Procurement Project	
Approved Budget for the Contract	

NOW THETREFORE, in consideration of the foregoing, the Parties undertake to enter into a JOINT VENTURE and sign a Joint Venture Agreement relative to their joint cooperation for this bid project, in the event that their bid is successful, furnishing the PABAC a duly signed and notarized copy thereof within ten (10) calendar days from receipt of Notice from the BAC that our bid has the lowest calculated responsive bid or highest rated responsive bid (as the case may be).

For purposes of this bid project, and unless modified by the terms of the Joint Venture Agreement, the following party shall be the authorized representative of the JV:

**JV Partner (Name of Company)**

**Authorized Rep of the JV Partner: (Per attached Secretary's Certificate)**

\_\_\_\_\_  
**Name**

\_\_\_\_\_  
**Designation**

That furthermore, the parties agree to be bound jointly and severally under the said Joint Venture Agreement;

THAT Finally, failure on our part to enter into the Joint Venture and/or sign the Joint Venture Agreement for any reason after the Notice of Award has been issued by shall be a ground for non-issuance by PABAC of the Notice to Proceed, forfeiture of our bid security and such other administrative and/or civil liabilities as may be imposed by PABAC under the provisions of Republic Act (RA) No 9184 and its Revised Implementing Rules and Regulations (IRR) , without any liability on the part of PABAC.

This undertaking shall form an integral part of our Eligibility documents for the above-cited project.

IN WITNESS WHEREOF, the parties have signed this Protocol/Undertaking on the date first above-written.

[JURAT]

SUBSCRIBED AND SWORN TO BEFORE ME this \_\_\_\_\_ day of \_\_\_\_\_ at \_\_\_\_\_, Philippines. Affiant exhibited to me his/her competent Evidence of identity (as defined by the 2004 Rules on Notarial Practice \_\_\_\_\_ issued \_\_\_\_\_ at \_\_\_\_\_, Philippines.

Doc No: \_\_\_\_\_  
Page No: \_\_\_\_\_  
Book No: \_\_\_\_\_  
Series of: \_\_\_\_\_

NOTARY PUBLIC

**Bidder's Company Letterhead****PROCUREMENT OF GRENADE LAUNCHER, 40MM  
FOR THE PHILIPPINE ARMY****BID REF NO. ORD PABAC 027-20****PABAC Chairperson**

Office of the PA Bids and Awards Committee  
Fort Andres Bonifacio, Metro Manila

Subject: **Statement of Inapplicability of Joint Venture Agreement**

Dear PABAC Chairperson,

This is to inform you that *[insert name of supplier or bidder]* is not joining as a Joint Venture for this project, thus, the Joint Venture Agreement is not applicable.

Thank you and more power.

Truly Yours,

Name and Signature of Authorized Representative

**CERTIFIED CORRECT:**

\_\_\_\_\_  
Name and Signature of Authorized Representative

\_\_\_\_\_  
Position

\_\_\_\_\_  
Date

## Annex 12-A1

(Bidder's Company Letterhead)

**PROCUREMENT OF GRENADE LAUNCHER, 40MM  
FOR THE PHILIPPINE ARMY**

**BID REF NO. ORD PABAC 027-20**

**FINANCIAL BID FORM**

Description	Qty	ABC Price		Bidder's Proposal	
		U/P	Total Price	U/P	Total Price
<b>TOTAL BID PRICE</b>					
<b>Total Bid Price (Amount in Words):</b>					
<b>BIDDER'S UNDERTAKING</b>					
I/We, the undersigned bidder, having examined the Bidding Documents including Bid Bulletins, as applicable, hereby OFFER to (supply/deliver/perform) the above-described items.					
I/We undertake, if our bid is accepted, to deliver the items in accordance with the terms and conditions contained in the bid documents, including the posting of the required performance security within ten (10) calendar days from receipt of Notice of Award.					
Until a formal contract/order confirmation is prepared and signed, this Bid is binding on us.					

Note: If the particular column is not applicable indicate **N/A**.

\_\_\_\_\_  
Name of Company (in print)

\_\_\_\_\_  
Signature of Company Representative

\_\_\_\_\_  
Name & Designation (in print)

\_\_\_\_\_  
Date

(Bidder's Company Letterhead)

PROCUREMENT OF GRENADE LAUNCHER, 40MM  
FOR THE PHILIPPINE ARMY

BID REF NO. ORD PABAC 027-20

For Goods Offered from Abroad

Name of Bidder \_\_\_\_\_ Invitation to Bid<sup>2</sup> Number \_\_\_\_ Page  
\_\_\_\_\_ of \_\_\_\_.

1	2	3	4	5	6	7	8	9
Item	Description	Country of origin	Qty	Unit price CIF port of entry (specify port) or CIF named place (specify border point or place of destination)	Total CIF or CIF price per item (col. 4 x 5)	Unit Price Delivered at Place (DAP)	Unit price Delivered Duty Paid (DDP)	Total Price -(if DAP col 4X7) -(If DDP col 4X8)

Note: If the particular column is not applicable indicate **dash (-)** or **zero (0)**, as applicable.

\_\_\_\_\_  
[signature]

\_\_\_\_\_  
[in the capacity of]

Duly authorized to sign Bid for and on behalf of \_\_\_\_\_

\_\_\_\_\_

<sup>2</sup> If ADB, JICA and WB funded projects, use IFB.

**Annex 12-A2**  
**FORM NO. 2**

**(Bidder's Company Letterhead)**

**PROCUREMENT OF GRENADE LAUNCHER, 40MM  
FOR THE PHILIPPINE ARMY**

**BID REF NO. ORD PABAC 027-20**

**For Goods Offered From Within the Philippines**

Name of Bidder \_\_\_\_\_ Invitation to Bid<sup>3</sup> Number \_\_\_\_ Page  
\_\_\_\_\_ of \_\_\_\_.

1	2	3	4	5	6	7	8	9	10
Item	Description	Country of origin	Quantity	Unit price EXW per item	Transportation and Insurance and all other costs incidental to delivery, per item	Sales and other taxes payable if Contract is awarded, per item	Cost of Incidental Services, if applicable, per item	Total Price, per unit (col 5+6+7+8)	Total Price delivered Final Destination (col 9) x (col 4)

Note: If the particular column is not applicable indicate **dash (-)** or **zero (0)**, as applicable.

\_\_\_\_\_  
*[signature]*

\_\_\_\_\_  
*[in the capacity of]*

Duly authorized to sign Bid for and on behalf of \_\_\_\_\_

<sup>3</sup> If ADB, JICA and WB funded projects, use IFB.

