



HEADQUARTERS
ARMED FORCES OF THE PHILIPPINES BIDS AND AWARDS COMMITTEE
OFFICE OF THE PHILIPPINE ARMY BIDS AND AWARDS COMMITTEE 1
Fort Andres Bonifacio, Taguig City

BIDDING DOCUMENTS

for the

Procurement of Various Tires

QM PABAC1 001-25

ABC: PhP182,638,904.00

DESCRIPTION	QUANTITY	TOTAL PRICE (PhP)
Tire, 36x12.5 R16.5 LT	8,663 each	166,398,904.00
Tire, 425x65 R22.5	80 each	6,272,000.00
Tire, 315x80 R22.5	100 each	9,968,000.00
TOTAL ABC		182,638,904.00

Table of Contents

Glossary of Acronyms, Terms, and Abbreviations	2
Section I. Invitation to Bid.....	5
Section II. Instructions to Bidders.....	7
1. Scope of Bid	7
2. Funding Information.....	7
3. Bidding Requirements	7
4. Corrupt, Fraudulent, Collusive, and Coercive Practices	7
5. Eligible Bidders.....	8
6. Origin of Goods	8
7. Subcontracts	8
8. Pre-Bid Conference	8
9. Clarification and Amendment of Bidding Documents	8
10. Documents comprising the Bid: Eligibility and Technical Components	9
11. Documents comprising the Bid: Financial Component	9
12. Bid Prices	9
13. Bid and Payment Currencies	10
14. Bid Security	10
15. Sealing and Marking of Bids	10
16. Deadline for Submission of Bids	11
17. Opening and Preliminary Examination of Bids	11
18. Domestic Preference	11
19. Detailed Evaluation and Comparison of Bids	11
20. Post-Qualification	12
21. Signing of the Contract	12
Section III. Bid Data Sheet	13
Section IV. General Conditions of Contract.....	17
1. Scope of Contract	17
2. Advance Payment and Terms of Payment	17
3. Performance Security	17
4. Inspection and Tests	17
5. Warranty	18
6. Liability of the Supplier	18
Section V. Special Conditions of Contract	19
Section VI. Schedule of Requirements	26
Section VII. Technical Specifications	27
Section VIII. Checklist of Technical and Financial Documents	39

Glossary of Acronyms, Terms, and Abbreviations

ABC – Approved Budget for the Contract.

BAC – Bids and Awards Committee.

Bid – A signed offer or proposal to undertake a contract submitted by a bidder in response to and in consonance with the requirements of the bidding documents. Also referred to as *Proposal* and *Tender*. (2016 revised IRR, Section 5[c])

Bidder – Refers to a contractor, manufacturer, supplier, distributor and/or consultant who submits a bid in response to the requirements of the Bidding Documents. (2016 revised IRR, Section 5[d])

Bidding Documents – The documents issued by the Procuring Entity as the bases for bids, furnishing all information necessary for a prospective bidder to prepare a bid for the Goods, Infrastructure Projects, and/or Consulting Services required by the Procuring Entity. (2016 revised IRR, Section 5[e])

BIR – Bureau of Internal Revenue.

BSP – Bangko Sentral ng Pilipinas.

Consulting Services – Refer to services for Infrastructure Projects and other types of projects or activities of the GOP requiring adequate external technical and professional expertise that are beyond the capability and/or capacity of the GOP to undertake such as, but not limited to: (i) advisory and review services; (ii) pre-investment or feasibility studies; (iii) design; (iv) construction supervision; (v) management and related services; and (vi) other technical services or special studies. (2016 revised IRR, Section 5[i])

CDA - Cooperative Development Authority.

Contract – Refers to the agreement entered into between the Procuring Entity and the Supplier or Manufacturer or Distributor or Service Provider for procurement of Goods and Services; Contractor for Procurement of Infrastructure Projects; or Consultant or Consulting Firm for Procurement of Consulting Services; as the case may be, as recorded in the Contract Form signed by the parties, including all attachments and appendices thereto and all documents incorporated by reference therein.

CIF – Cost Insurance and Freight.

CIP – Carriage and Insurance Paid.

CPI – Consumer Price Index.

DDP – Refers to the quoted price of the Goods, which means “delivered duty paid.”

DTI – Department of Trade and Industry.

EXW – Ex works.

FCA – “Free Carrier” shipping point.

FOB – “Free on Board” shipping point.

Foreign-funded Procurement or Foreign-Assisted Project–Refers to procurement whose funding source is from a foreign government, foreign or international financing institution as specified in the Treaty or International or Executive Agreement. (2016 revised IRR, Section 5[b]).

Framework Agreement – Refers to a written agreement between a procuring entity and a supplier or service provider that identifies the terms and conditions, under which specific purchases, otherwise known as “Call-Offs,” are made for the duration of the agreement. It is in the nature of an option contract between the procuring entity and the bidder(s) granting the procuring entity the option to either place an order for any of the goods or services identified in the Framework Agreement List or not buy at all, within a minimum period of one (1) year to a maximum period of three (3) years. (GPPB Resolution No. 27-2019)

GFI – Government Financial Institution.

GOCC –Government-owned and/or –controlled corporation.

Goods – Refer to all items, supplies, materials and general support services, except Consulting Services and Infrastructure Projects, which may be needed in the transaction of public businesses or in the pursuit of any government undertaking, project or activity, whether in the nature of equipment, furniture, stationery, materials for construction, or personal property of any kind, including non-personal or contractual services such as the repair and maintenance of equipment and furniture, as well as trucking, hauling, janitorial, security, and related or analogous services, as well as procurement of materials and supplies provided by the Procuring Entity for such services. The term “related” or “analogous services” shall include, but is not limited to, lease or purchase of office space, media advertisements, health maintenance services, and other services essential to the operation of the Procuring Entity. (2016 revised IRR, Section 5[r])

GOP – Government of the Philippines.

GPPB –Government Procurement Policy Board.

INCOTERMS – International Commercial Terms.

Infrastructure Projects – Include the construction, improvement, rehabilitation, demolition, repair, restoration or maintenance of roads and bridges, railways, airports, seaports, communication facilities, civil works components of information technology projects, irrigation, flood control and drainage, water supply, sanitation, sewerage and solid waste management systems, shore protection, energy/power and electrification facilities, national

buildings, school buildings, hospital buildings, and other related construction projects of the government. Also referred to as *civil works or works*. (2016 revised IRR, Section 5[u])

LGUs – Local Government Units.

NFCC – Net Financial Contracting Capacity.

NGA – National Government Agency.

PhilGEPS - Philippine Government Electronic Procurement System.

Procurement Project – refers to a specific or identified procurement covering goods, infrastructure project or consulting services. A Procurement Project shall be described, detailed, and scheduled in the Project Procurement Management Plan prepared by the agency which shall be consolidated in the procuring entity's Annual Procurement Plan. (GPPB Circular No. 06-2019 dated 17 July 2019)

PSA – Philippine Statistics Authority.

SEC – Securities and Exchange Commission.

SLCC – Single Largest Completed Contract.

Supplier – refers to a citizen, or any corporate body or commercial company duly organized and registered under the laws where it is established, habitually established in business and engaged in the manufacture or sale of the merchandise or performance of the general services covered by his bid. (Item 3.8 of GPPB Resolution No. 13-2019, dated 23 May 2019). Supplier as used in these Bidding Documents may likewise refer to a distributor, manufacturer, contractor, or consultant.

UN – United Nations.

Section I. Invitation to Bid

HEADQUARTERS
ARMED FORCES OF THE PHILIPPINES BIDS AND AWARDS COMMITTEE
OFFICE OF THE PHILIPPINE ARMY BIDS AND AWARDS COMMITTEE 1
Fort Andres Bonifacio, Metro Manila

INVITATION TO BID FOR THE PROCUREMENT OF VARIOUS TIRES

1. The Philippine Army, through the **Philippine Army Appropriation CY 2025 with OG10 Certification dated 02 August 2024 valid until 31 December 2026**, intends to apply the sum of the following amounts being the ABC to payments under the contract for the **Procurement of Various tires under QM PABAC1 001-25**. Bids received in excess of the ABC shall be automatically rejected at bid opening.

DESCRIPTION	QUANTITY	TOTAL PRICE (PhP)
Tire, 36x12.5 R16.5 LT	8,663 each	166,398,904.00
Tire, 425x65 R22.5	80 each	6,272,000.00
Tire, 315x80 R22.5	100 each	9,968,000.00
TOTAL ABC		182,638,904.00

2. The Philippine Army now invites bids for the above Procurement Project. Delivery of the Goods is required **Two Hundred Fifty (250) calendar days from the receipt of Notice to Proceed (NTP)** by the supplier, which date shall not be later than seven (7) days from the issuance of NTP. Bidders should have completed, within five (5) years from the date of submission and receipt of bids, a contract similar to the Project. The description of an eligible bidder is contained in the Bidding Documents, particularly, in Section II (Instructions to Bidders).
3. Bidding will be conducted through open competitive bidding procedures using a non-discretionary “*pass/fail*” criterion as specified in the 2016 revised Implementing Rules and Regulations (IRR) of Republic Act (RA) No. 9184.

Bidding is open to all interested bidders, whether local or foreign, subject to the conditions for eligibility provided in the 2016 revised IRR of RA No. 9184.

4. Prospective Bidders may obtain further information from the Philippine Army and inspect the Bidding Documents at the address given below office hours (8:00AM to 4:00PM) on weekdays only.
5. A complete set of Bidding Documents may be acquired by interested Bidders on October 2, 2024 from the given address and website(s) below and upon payment of the applicable fee for the Bidding Documents, pursuant to the latest Guidelines issued by the GPPB in the amount of **Fifty Thousand Pesos (PhP50,000.00)**. The Procuring Entity shall allow the bidder to present its proof of payment for the fees in person, by facsimile, or through electronic means.
6. The Philippine Army through PABAC1 will hold a Pre-Bid Conference on the time and date as specified below at the Office of the PABAC1, Fort Andres Bonifacio, Taguig, and/or through video conferencing or webcasting via Zoom, which shall be open to prospective bidders.

7. Bids must be duly received by the BAC Secretariat through manual submission at the office address indicated below, on or before the date of submission. Late bids shall not be accepted.
8. All Bids must be accompanied by a bid security in any of the acceptable forms and in the amount stated in **ITB** Clause 14.
9. Bid opening shall be on the date as specified below and at the given address below and/or through video conferencing or webcasting. Bids will be opened in the presence of the bidders’ representatives who choose to attend the activity.

The schedule of the bidding activities shall be as follows:

ACTIVITIES	TIME and DATE	VENUE
1. Sale and Issuance of Bidding Documents	8:00AM to 4:00PM Mondays to Fridays only starting on October 2, 2024	Office of the PABAC1 Secretariat/Conference Room, PABAC Building, Fort Andres Bonifacio, Taguig City
2. Pre-Bid Conference	October 9, 2024 @ 8:30 A.M (Wed)	
3. Deadline of Submission of Bids	On or before October 22, 2024 @ 9:00 A.M (Tue)	
4. Opening of Bids and Evaluation	October 22, 2024 @ 9:00 A.M (Tue) Onwards	

10. The Philippine Army reserves the right to reject any and all bids, declare a failure of bidding, or not award the contract at any time prior to contract award in accordance with Sections 35.6 and 41 of the 2016 revised IRR of RA No. 9184, without thereby incurring any liability to the affected bidder or bidders.

Tie breaking method shall be non-discretionary and non-discriminatory. The same shall be based on sheer luck or chance (Toss Coin) and in chronological order based on the submission of bids.

11. For further information, please refer to:

Office of the PA Bids and Awards Committee 1
 Fort Andres Bonifacio, Taguig City
MGEN LEONEL M NICOLAS PA
PABAC1 Chairperson
 Contact Nr. +63999-321-1164/+63977-488-0012
 Telephone Nr. 845-9555 local 6891
 Email address: pabacsec@gmail.com

12. You may visit the following websites:
 For downloading of Bidding Documents:
 - *philgeps.gov.ph*
 - *army.mil.ph*

Date of issue: _____



MGEN LEONEL M NICOLAS
PABAC1 Chairperson

Section II. Instructions to Bidders

1. Scope of Bid

The Procuring Entity, Philippine Army wishes to receive Bids for the **Procurement of Various tires under QM PABAC1 001-25.**

The Procurement Project (referred to herein as “Project”) is composed of **one lot, the details of which are described in Section VII (Technical Specifications).**

2. Funding Information

2.1. The GOP through the source of funding as indicated below for 2025 in the amount of:

DESCRIPTION	QUANTITY	TOTAL PRICE (PhP)
Tire, 36x12.5 R16.5 LT	8,663 each	166,398,904.00
Tire, 425x65 R22.5	80 each	6,272,000.00
Tire, 315x80 R22.5	100 each	9,968,000.00
TOTAL ABC		182,638,904.00

2.2. The source of funding is: NGA, National Expenditure Program (NEP).

3. Bidding Requirements

The Bidding for the Project shall be governed by all the provisions of RA No. 9184 and its 2016 revised IRR, including its Generic Procurement Manuals and associated policies, rules and regulations as the primary source thereof, while the herein clauses shall serve as the secondary source thereof.

Any amendments made to the IRR and other GPPB issuances shall be applicable only to the ongoing posting, advertisement, or **IB** by the BAC through the issuance of a supplemental or bid bulletin.

The Bidder, by the act of submitting its Bid, shall be deemed to have verified and accepted the general requirements of this Project, including other factors that may affect the cost, duration and execution or implementation of the contract, project, or work and examine all instructions, forms, terms, and project requirements in the Bidding Documents.

4. Corrupt, Fraudulent, Collusive, and Coercive Practices

The Procuring Entity, as well as the Bidders and Suppliers, shall observe the highest standard of ethics during the procurement and execution of the contract. They or through an agent shall not engage in corrupt, fraudulent, collusive, coercive, and obstructive practices defined under Annex “I” of the 2016 revised IRR of RA No. 9184 or other integrity violations in competing for the Project.

5. Eligible Bidders

- 5.1. Only Bids of Bidders found to be legally, technically, and financially capable will be evaluated.
- 5.2. Foreign ownership exceeding those allowed under the rules may participate pursuant to:
 - i. When a Treaty or International or Executive Agreement as provided in Section 4 of the RA No. 9184 and its 2016 revised IRR allow foreign bidders to participate;
 - ii. Citizens, corporations, or associations of a country, included in the list issued by the GPPB, the laws or regulations of which grant reciprocal rights or privileges to citizens, corporations, or associations of the Philippines;
 - iii. When the Goods sought to be procured are not available from local suppliers; or
 - iv. When there is a need to prevent situations that defeat competition or restrain trade.
- 5.3. Pursuant to Section 23.4.1.3 of the 2016 revised IRR of RA No.9184, the Bidder shall have an SLCC that is at least one (1) contract similar to the Project the value of which, adjusted to current prices using the PSA's CPI, must be at least equivalent to at least twenty-five percent (25%) of the ABC (Expendable Supplies)
- 5.4. The Bidders shall comply with the eligibility criteria under Section 23.4.1 of the 2016 IRR of RA No. 9184.

6. Origin of Goods

There is no restriction on the origin of goods other than those prohibited by a decision of the UN Security Council taken under Chapter VII of the Charter of the UN, subject to Domestic Preference requirements under **ITB** Clause 18.

7. Subcontracts

7.1. The Procuring Entity has prescribed that: **Subcontracting is not allowed.**

8. Pre-Bid Conference

The Procuring Entity will hold a pre-bid conference for this Project on the specified date and time and either at its physical address and/or through videoconferencing/webcasting as indicated in paragraph 6 of the **IB**.

9. Clarification and Amendment of Bidding Documents

Prospective bidders may request for clarification on and/or interpretation of any part of the Bidding Documents. Such requests must be in writing and received by the

Procuring Entity, either at its given address or through electronic mail indicated in the **IB**, at least ten (10) calendar days before the deadline set for the submission and receipt of Bids.

10. Documents comprising the Bid: Eligibility and Technical Components

10.1. The first envelope shall contain the eligibility and technical documents of the Bid as specified in **Section VIII (Checklist of Technical and Financial Documents)**.

10.2. The Bidder's SLCC as indicated in **ITB Clause 5.3** should have been completed within five (5) years prior to the deadline for the submission and receipt of bids.

10.3. If the eligibility requirements or statements, the bids, and all other documents for submission to the BAC are in foreign language other than English, it must be accompanied by a translation in English, which shall be authenticated by the appropriate Philippine foreign service establishment, post, or the equivalent office having jurisdiction over the foreign bidder's affairs in the Philippines. Similar to the required authentication above, for Contracting Parties to the Apostille Convention, only the translated documents shall be authenticated through an apostille pursuant to GPPB Resolution No. 13-2019 dated 23 May 2019. The English translation shall govern, for purposes of interpretation of the bid.

11. Documents comprising the Bid: Financial Component

11.1. The second bid envelope shall contain the financial documents for the Bid as specified in **Section VIII (Checklist of Technical and Financial Documents)**.

11.2. If the Bidder claims preference as a Domestic Bidder or Domestic Entity, a certification issued by DTI shall be provided by the Bidder in accordance with Section 43.1.3 of the 2016 revised IRR of RA No. 9184.

11.3. Any bid exceeding the ABC indicated in paragraph 1 of the **IB** shall not be accepted.

11.4. For Foreign-funded Procurement, a ceiling may be applied to bid prices provided the conditions are met under Section 31.2 of the 2016 revised IRR of RA No. 9184.

12. Bid Prices

12.1. Prices indicated on the Price Schedule shall be entered separately in the following manner:

- a. For Goods offered from within the Procuring Entity's country:

- i. The price of the Goods quoted EXW (ex-works, ex-factory, ex-warehouse, ex-showroom, or off-the-shelf, as applicable);
 - ii. The cost of all customs duties and sales and other taxes already paid or payable;
 - iii. The cost of transportation, insurance, and other costs incidental to delivery of the Goods to their final destination; and
 - iv. The price of other (incidental) services, if any, listed in e.
- b. For Goods offered from abroad:
- i. Unless otherwise stated in the **BDS**, the price of the Goods shall be quoted delivered duty paid (DDP) with the place of destination in the Philippines as specified in the **BDS**. In quoting the price, the Bidder shall be free to use transportation through carriers registered in any eligible country. Similarly, the Bidder may obtain insurance services from any eligible source country.
 - ii. The price of other (incidental) services, if any, as listed in **Section VII (Technical Specifications)**.

13. Bid and Payment Currencies

- 13.1. For Goods that the Bidder will supply from outside the Philippines, the bid prices may be quoted in the local currency or tradeable currency accepted by the BSP at the discretion of the Bidder. However, for purposes of bid evaluation, Bids denominated in foreign currencies, shall be converted to Philippine currency based on the exchange rate as published in the BSP reference rate bulletin on the day of the bid opening.

13.2. Payment of the contract price shall be made in Philippine Peso.

14. Bid Security

- 14.1. The Bidder shall submit a Bid Securing Declaration or any form of Bid Security in the amount indicated in the **BDS**, which shall be not less than the percentage of the ABC in accordance with the schedule in the **BDS**.
- 14.2. The Bid and bid security shall be valid within one hundred twenty (120) calendar days from the date of the opening of bids. Any Bid not accompanied by an acceptable bid security shall be rejected by the Procuring Entity as non-responsive.

15. Sealing and Marking of Bids

Each Bidder shall submit one copy of the first and second components of its Bid.

The Procuring Entity may request additional hard copies and/or electronic copies of the Bid. However, failure of the Bidders to comply with the said request shall not be a ground for disqualification.

If the Procuring Entity allows the submission of bids through online submission or any other electronic means, the Bidder shall submit an electronic copy of its Bid, which must be digitally signed. An electronic copy that cannot be opened or is corrupted shall be considered non-responsive and, thus, automatically disqualified.

16. Deadline for Submission of Bids

16.1. The Bidders shall submit on the specified date and time and either at its physical address or through online submission as indicated in paragraph 7 of the **IB**.

17. Opening and Preliminary Examination of Bids

17.1. The BAC shall open the Bids in public at the time, on the date, and at the place specified in paragraph 9 of the **IB**. The Bidders' representatives who are present shall sign a register evidencing their attendance. In case videoconferencing, webcasting or other similar technologies will be used, attendance of participants shall likewise be recorded by the BAC Secretariat.

In case the Bids cannot be opened as scheduled due to justifiable reasons, the rescheduling requirements under Section 29 of the 2016 revised IRR of RA No. 9184 shall prevail.

17.2. The preliminary examination of bids shall be governed by Section 30 of the 2016 revised IRR of RA No. 9184.

18. Domestic Preference

18.1. The Procuring Entity will grant a margin of preference for the purpose of comparison of Bids in accordance with Section 43.1.2 of the 2016 revised IRR of RA No. 9184.

19. Detailed Evaluation and Comparison of Bids

19.1. The Procuring BAC shall immediately conduct a detailed evaluation of all Bids rated "*passed*," using non-discretionary pass/fail criteria. The BAC shall consider the conditions in the evaluation of Bids under Section 32.2 of the 2016 revised IRR of RA No. 9184.

19.2. If the Project allows partial bids, bidders may submit a proposal on any of the lots or items, and evaluation will be undertaken on a per lot or item basis, as the case maybe. In this case, the Bid Security as required by **ITB** Clause 15 shall be submitted for each lot or item separately.

19.3. The descriptions of the lots or items shall be indicated in **Section VII (Technical Specifications)**, although the ABCs of these lots or items are

indicated in the **BDS** for purposes of the NFCC computation pursuant to Section 23.4.2.6 of the 2016 revised IRR of RA No. 9184. The NFCC must be sufficient for the total of the ABCs for all the lots or items participated in by the prospective Bidder.

19.4. The Project shall be awarded as follows:

One Project having several items shall be awarded as one contract.

19.5. Except for bidders submitting a committed Line of Credit from a Universal or Commercial Bank in lieu of its NFCC computation, all Bids must include the NFCC computation pursuant to Section 23.4.1.4 of the 2016 revised IRR of RA No. 9184, which must be sufficient for the total of the ABCs for all the lots or items participated in by the prospective Bidder. For bidders submitting the committed Line of Credit, it must be at least equal to ten percent (10%) of the ABCs for all the lots or items participated in by the prospective Bidder.

20. Post-Qualification

20.2. Within a non-extendible period of five (5) calendar days from receipt by the Bidder of the notice from the BAC that it submitted the Lowest Calculated Bid, the Bidder shall submit its latest income and business tax returns filed and paid through the BIR Electronic Filing and Payment System (eFPS) and other appropriate licenses and permits required by law and stated in the **BDS**.

21. Signing of the Contract

21.1. The documents required in Section 37.2 of the 2016 revised IRR of RA No. 9184 shall form part of the Contract. Additional Contract documents are indicated in the **BDS**.

Section III. Bid Data Sheet

ITB Clause	
5.3	<p>For this purpose, contracts similar to the Project shall be:</p> <p style="margin-left: 40px;">a. Supply and Delivery of “any pneumatic tires”; and</p> <p style="margin-left: 40px;">b. Completed within five (5) years prior to the deadline for the submission and receipt of bids.</p>
7.1	No portion of the contract or project shall be sub-contracted.
10	<p>For foreign bidders, the equivalent document/s issued by the appropriate authority in the country of origin of the bidder concerned must be presented. If said document has no appropriate equivalent, a Certificate of Inexistence of Appropriate Foreign Equivalent may be submitted.</p> <p>The local representative of Foreign Bidders shall also submit PhilGEPS Certificate of Registration (Platinum Membership), or a Valid and Current Proof of Authority issued by the foreign bidder (in case the authorized local representative is an individual).</p> <p>In case of a Joint Venture, each JV partner shall submit the required Legal Documents.</p>
12	For the given scope of work in this Contract as awarded, all bid prices are considered fixed prices, and therefore not subject to price escalation during contract implementation, except under extraordinary circumstances and upon prior approval of the GPPB in accordance with Section 61 of R.A. 9184 and its IRR.
12.1	The price of the Goods shall be quoted DDP <i>GS Warehouse 1LSG, Army Support Command, PA, Camp General Servillano Aquino, San Miguel, Tarlac City and 10FSSU, 2LSG, ASCOM, PA, Camp Evangelista, Patag, Cagayan de Oro City</i> the applicable International Commercial Terms (INCOTERMS) for this Project.
14.1	<p>The bid security shall be in the form of a Bid Securing Declaration, or any of the following forms and amounts:</p> <p style="margin-left: 40px;">a. The amount of not less than PhP3,652,778.08 two percent (2%) of the ABC, if bid security is in cash, cashier’s/manager’s check, bank draft/guarantee or irrevocable letter of credit; or</p> <p style="margin-left: 40px;">b. The amount of not less than PhP9,131,945.20 five percent (5%) of the ABC, if bid security is in Surety Bond.</p> <p>Note: The bid security shall be payable to the Procuring Entity, however, if it is in the form of a manager’s check, it shall be payable to the Collecting Officer, Finance Center, PA.</p>

15	<p>Each Bidder shall submit one (1) original and two (2) photocopies of the first and second components of its bid with proper tabbing.</p> <p>Note:</p> <ul style="list-style-type: none"> Unsealed and unsigned Bid Envelope and failure to submit the required original copy shall be grounds for disqualification 																							
18	Certification from the DTI if the Bidder claims preference as a Domestic Bidder or Domestic Entity.																							
19.3	<p>The Project shall be awarded as one contract.</p> <table border="1"> <thead> <tr> <th>Description</th> <th>Qty</th> <th>U/P (PhP)</th> <th>TOTAL PRICE (PhP)</th> <th>END USER</th> </tr> </thead> <tbody> <tr> <td>Tire, 36x12.5 R16.5 LT</td> <td>8,663 ea</td> <td>19,208.00</td> <td>166,398,904.00</td> <td rowspan="3">PAMUs</td> </tr> <tr> <td>Tire, 425x65 R22.5</td> <td>80 ea</td> <td>78,400.00</td> <td>6,272,000.00</td> </tr> <tr> <td>Tire, 315x80 R22.5</td> <td>100 ea</td> <td>99,680.00</td> <td>9,968,000.00</td> </tr> <tr> <td colspan="3" style="text-align: center;">TOTAL ABC</td> <td>182,638,904.00</td> <td></td> </tr> </tbody> </table>	Description	Qty	U/P (PhP)	TOTAL PRICE (PhP)	END USER	Tire, 36x12.5 R16.5 LT	8,663 ea	19,208.00	166,398,904.00	PAMUs	Tire, 425x65 R22.5	80 ea	78,400.00	6,272,000.00	Tire, 315x80 R22.5	100 ea	99,680.00	9,968,000.00	TOTAL ABC			182,638,904.00	
Description	Qty	U/P (PhP)	TOTAL PRICE (PhP)	END USER																				
Tire, 36x12.5 R16.5 LT	8,663 ea	19,208.00	166,398,904.00	PAMUs																				
Tire, 425x65 R22.5	80 ea	78,400.00	6,272,000.00																					
Tire, 315x80 R22.5	100 ea	99,680.00	9,968,000.00																					
TOTAL ABC			182,638,904.00																					
20.2	<p>Post-Qualification Requirements:</p> <table border="1"> <thead> <tr> <th>TAB</th> <th>Additional Post Qualification Requirements</th> <th>Legal Basis</th> </tr> </thead> <tbody> <tr> <td>A</td> <td>Registration Certificate from Securities and Exchange Commission (SEC) for corporations, Department of Trade and Industry (DTI) for sole proprietorship, or Cooperative Development Authority (CDA) for cooperatives or its equivalent document</td> <td>2016 Revised IRR of RA No 9184</td> </tr> <tr> <td>B</td> <td>Current and valid Mayor's Permit or Business Permit issued by the local government where the principal place of business of the bidder is located</td> <td>2016 Revised IRR of RA No 9184</td> </tr> <tr> <td>C</td> <td>Tax Clearance Certificate per Executive Order 398, Series of 2005</td> <td>2016 Revised IRR of RA No 9184</td> </tr> <tr> <td>D</td> <td>Latest Income and Business Tax Returns filed and paid through the BIR Electronic Filing and Payment System (eFPS). The latest income and business tax returns are those within the last six (6) months preceding the date of bid submission.</td> <td>2016 Revised IRR of RA No 9184</td> </tr> <tr> <td>E</td> <td>Latest Audited Financial Statement showing, among others, the prospective bidder's total and current assets and liabilities stamped "received" if manually filed or "attachment of system generated Transaction Reference Number and email to the system user" if electronically filed issued by the Bureau of Internal Revenue or its duly accredited and authorized institutions, for</td> <td>2016 Revised IRR of RA No 9184</td> </tr> </tbody> </table>	TAB	Additional Post Qualification Requirements	Legal Basis	A	Registration Certificate from Securities and Exchange Commission (SEC) for corporations, Department of Trade and Industry (DTI) for sole proprietorship, or Cooperative Development Authority (CDA) for cooperatives or its equivalent document	2016 Revised IRR of RA No 9184	B	Current and valid Mayor's Permit or Business Permit issued by the local government where the principal place of business of the bidder is located	2016 Revised IRR of RA No 9184	C	Tax Clearance Certificate per Executive Order 398, Series of 2005	2016 Revised IRR of RA No 9184	D	Latest Income and Business Tax Returns filed and paid through the BIR Electronic Filing and Payment System (eFPS). The latest income and business tax returns are those within the last six (6) months preceding the date of bid submission.	2016 Revised IRR of RA No 9184	E	Latest Audited Financial Statement showing, among others, the prospective bidder's total and current assets and liabilities stamped " received " if manually filed or " attachment of system generated Transaction Reference Number and email to the system user " if electronically filed issued by the Bureau of Internal Revenue or its duly accredited and authorized institutions, for	2016 Revised IRR of RA No 9184					
TAB	Additional Post Qualification Requirements	Legal Basis																						
A	Registration Certificate from Securities and Exchange Commission (SEC) for corporations, Department of Trade and Industry (DTI) for sole proprietorship, or Cooperative Development Authority (CDA) for cooperatives or its equivalent document	2016 Revised IRR of RA No 9184																						
B	Current and valid Mayor's Permit or Business Permit issued by the local government where the principal place of business of the bidder is located	2016 Revised IRR of RA No 9184																						
C	Tax Clearance Certificate per Executive Order 398, Series of 2005	2016 Revised IRR of RA No 9184																						
D	Latest Income and Business Tax Returns filed and paid through the BIR Electronic Filing and Payment System (eFPS). The latest income and business tax returns are those within the last six (6) months preceding the date of bid submission.	2016 Revised IRR of RA No 9184																						
E	Latest Audited Financial Statement showing, among others, the prospective bidder's total and current assets and liabilities stamped " received " if manually filed or " attachment of system generated Transaction Reference Number and email to the system user " if electronically filed issued by the Bureau of Internal Revenue or its duly accredited and authorized institutions, for	2016 Revised IRR of RA No 9184																						

		the preceding calendar year which should not be earlier than two (2) years from the date of bid submission.	
F		Submitted Prototype samples for testing during SOBE will be the final sample	Required samples for Test and Evaluation Procedure under QM SPEC NR OE-23T36R165 dated 30 May 2017; QM SPEC NR OE-23T425x65 R22.5 dated 09 Aug 2019; and QM SPEC NR OE-23T315x80 R22.5 dated 09 Aug 2019
G		Certificate from AFPPS that the bidder is not Blacklisted if not submitted during bid opening	2016 Revised IRR of RA No 9184
H		Certificate of Notarial Commission of the lawyer who notarized the documents submitted by the bidder	2016 Revised IRR of RA No 9184
I		Supporting documents for the Ongoing Government/Private Contracts and the Single Largest Completed Contract: 1. Notice of Award, AND/OR Notice to Proceed, AND/OR Purchase Orders AND/OR Contracts for all Ongoing Contracts as listed per submitted Annex 1; 2. Notice of Award, Notice to Proceed, Purchase Orders OR Contracts relative to Single Largest Completed Contract per submitted Annex 2 3. Certificate of Completion OR Technical Inspection and Acceptance Committee (TIAC) Report OR Official Receipt (duplicate or triplicate copy) OR Sales Invoice with Collection Receipt (duplicate or triplicate copy) OR End-User's Acceptance relative to the Single Largest Completed Contract per submitted Annex 2	2016 Revised IRR of RA No 9184
J		Company Profile (Organization, Affiliated Companies, Production Capability – if applicable)	
K		Vicinity map/location of the business	

FOR FOREIGN MANUFACTURER/BIDDER:

- **The equivalent to the above-enumerated Class “A” documents issued by country or place of business, in English shall be submitted.** If not in English, it must be accompanied by a translation in English, which shall be authenticated by the appropriate Philippine foreign service establishment, post, or the equivalent office having jurisdiction over the foreign bidder’s affairs in the Philippines. Similar to the required authentication above, for Contracting Parties to the Apostille Convention, all said documents shall be authenticated through an apostille pursuant to GPPB Resolution No. 13-2019 dated 23 May 2019. The English translation shall govern, for purposes of interpretation of the bid; AND

Note: *For the Local representative of the foreign bidder: It must likewise submit and present **Registration Certificate** from the Securities and Exchange Commission (SEC), Department of Trade and Industry (DTI) for sole proprietorship, or CDA for cooperatives; and, its Valid and current **Mayor’s/Business permit** issued by the local government where the principal place of business of the bidder is located.*

In case of Joint Venture (both local and foreign manufacturers), both partners must present/submit the above documents.

Section IV. General Conditions of Contract

1. Scope of Contract

This Contract shall include all such items, although not specifically mentioned, that can be reasonably inferred as being required for its completion as if such items were expressly mentioned herein. All the provisions of RA No. 9184 and its 2016 revised IRR, including the Generic Procurement Manual, and associated issuances, constitute the primary source for the terms and conditions of the Contract, and thus, applicable in contract implementation. Herein clauses shall serve as the secondary source for the terms and conditions of the Contract.

This is without prejudice to Sections 74.1 and 74.2 of the 2016 revised IRR of RA No. 9184 allowing the GPPB to amend the IRR, which shall be applied to all procurement activities, the advertisement, posting, or invitation of which were issued after the effectivity of the said amendment.

Additional requirements for the completion of this Contract shall be provided in the **Special Conditions of Contract (SCC)**.

2. Advance Payment and Terms of Payment

- 2.1. Advance payment of the contract amount is provided under Annex “D” of the revised 2016 IRR of RA No. 9184.
- 2.2. The Procuring Entity is allowed to determine the terms of payment on the partial or staggered delivery of the Goods procured, provided such partial payment shall correspond to the value of the goods delivered and accepted in accordance with prevailing accounting and auditing rules and regulations. The terms of payment are indicated in the **SCC**.

3. Performance Security

Within ten (10) calendar days from receipt of the Notice of Award by the Bidder from the Procuring Entity but in no case later than prior to the signing of the Contract by both parties, the successful Bidder shall furnish the performance security in any of the forms prescribed in Section 39 of the 2016 revised IRR of RA No. 9184.

4. Inspection and Tests

The Procuring Entity or its representative shall have the right to inspect and/or to test the Goods to confirm their conformity to the specifications at no extra cost to the Procuring Entity in accordance with the Generic Procurement Manual. In addition to tests in the **SCC**, **Section IV (Technical Specifications)** shall specify what inspections and/or tests the Procuring Entity requires, and where they are to be conducted. The Procuring Entity shall notify the Supplier in writing, in a timely manner, of the identity of any representatives retained for these purposes.

All reasonable facilities and assistance for the inspection and testing of Goods, including access to drawings and production data, shall be provided by the Supplier to the authorized inspectors at no charge to the Procuring Entity.

5. Warranty

- 5.1 In order to assure that manufacturing defects shall be corrected by the Supplier, a warranty shall be required from the Supplier as provided under Section 62.1 of the 2016 revised IRR of RA No. 9184.
- 5.2 The Procuring Entity shall promptly notify the Supplier in writing of any claims arising under this warranty. Upon receipt of such notice, the Supplier shall, repair or replace the defective Goods or parts thereof without cost to the Procuring Entity, pursuant to the Generic Procurement Manual.

6. Liability of the Supplier

The Supplier's liability under this Contract shall be as provided by the laws of the Republic of the Philippines.

If the Supplier is a joint venture, all partners to the joint venture shall be jointly and severally liable to the Procuring Entity.

Section V. Special Conditions of Contract

GCC Clause	
1	<p>Delivery and Documents –</p> <p>For purposes of the Contract, “EXW,” “FOB,” “FCA,” “CIF,” “CIP,” “DDP” and other trade terms used to describe the obligations of the parties shall have the meanings assigned to them by the current edition of INCOTERMS published by the International Chamber of Commerce, Paris. The Delivery terms of this Contract shall be as follows:</p> <p><i>For Goods supplied from abroad: “The delivery terms applicable to the Contract is DDP delivered at GS Warehouse 1LSG, Army Support Command, PA, Camp General Servillano Aquino, San Miguel, Tarlac City and 10FSSU, 2LSG, ASCOM, PA, Camp Evangelista, Patag, Cagayan de Oro City in accordance with INCOTERMS.”</i></p> <p><i>For Goods supplied from within the Philippines: “The delivery terms applicable to this Contract is DDP delivered at GS Warehouse 1LSG, Army Support Command, PA, Camp General Servillano Aquino, San Miguel, Tarlac City and 10FSSU, 2LSG, ASCOM, PA, Camp Evangelista, Patag, Cagayan de Oro City. Risk and title will pass from the Supplier to the Procuring Entity upon receipt and final acceptance of the Goods at their final destination.”</i></p> <p>Delivery of the Goods shall be made by the Supplier in accordance with the terms specified in Section VI (Schedule of Requirements).</p> <p>For purposes of this Clause the Procuring Entity’s Representative at the Project Site is: PA TIAC, APAO, PA, and G10, PA.</p> <p>Incidental Services –(if applicable)</p> <p>The Supplier is required to provide all of the following services, including additional services, if any, specified in Section VI. Schedule of Requirements:</p> <ol style="list-style-type: none"> a. performance or supervision of on-site assembly and/or start-up of the supplied Goods; b. furnishing of tools required for assembly and/or maintenance of the supplied Goods; c. furnishing of a detailed operations and maintenance manual for each appropriate unit of the supplied Goods; d. performance or supervision or maintenance and/or repair of the supplied Goods, for a period of time agreed by the parties, provided that this service shall not relieve the Supplier of any warranty obligations under this Contract; and

	<p>e. training of the Procuring Entity’s personnel, at the Supplier’s plant and/or on-site, in assembly, start-up, operation, maintenance, and/or repair of the supplied Goods.</p> <p>The Contract price for the Goods shall include the prices charged by the Supplier for incidental services and shall not exceed the prevailing rates charged to other parties by the Supplier for similar services.</p>
	<p>Packaging –(if applicable)</p> <p>The Supplier shall provide such packaging of the Goods as is required to prevent their damage or deterioration during transit to their final destination, as indicated in this Contract. The packaging shall be sufficient to withstand, without limitation, rough handling during transit and exposure to extreme temperatures, salt and precipitation during transit, and open storage. Packaging case size and weights shall take into consideration, where appropriate, the remoteness of the Goods’ final destination and the absence of heavy handling facilities at all points in transit.</p> <p>The packaging, marking, and documentation within and outside the packages shall comply strictly with such special requirements as shall be expressly provided for in the Contract, including additional requirements, if any, specified below, and in any subsequent instructions ordered by the Procuring Entity.</p> <p>The outer packaging must be clearly marked as specified in Packaging and Packing of the Technical Specification for this Project.</p>
	<p>A packaging list identifying the contents and quantities of the package is to be placed on an accessible point of the outer packaging if practical. If not practical the packaging list is to be placed inside the outer packaging but outside the secondary packaging.</p> <p>Transportation –</p> <p>Where the Supplier is required under Contract to deliver the Goods CIF, CIP, or DDP, transport of the Goods to the port of destination or such other named place of destination in the Philippines, as shall be specified in this Contract, shall be arranged and paid for by the Supplier, and the cost thereof shall be included in the Contract Price.</p> <p>Where the Supplier is required under this Contract to transport the Goods to a specified place of destination within the Philippines, defined as the Project Site, transport to such place of destination in the Philippines, including insurance and storage, as shall be specified in this Contract, shall be arranged by the Supplier, and related costs shall be included in the contract price.</p>

	<p>Where the Supplier is required under Contract to deliver the Goods CIF, CIP or DDP, Goods are to be transported on carriers of Philippine registry. In the event that no carrier of Philippine registry is available, Goods may be shipped by a carrier which is not of Philippine registry provided that the Supplier obtains and presents to the Procuring Entity certification to this effect from the nearest Philippine consulate to the port of dispatch. In the event that carriers of Philippine registry are available but their schedule delays the Supplier in its performance of this Contract the period from when the Goods were first ready for shipment and the actual date of shipment the period of delay will be considered force majeure.</p> <p>The Procuring Entity accepts no liability for the damage of Goods during transit other than those prescribed by INCOTERMS for DDP deliveries. In the case of Goods supplied from within the Philippines or supplied by domestic suppliers' risk and title will not be deemed to have passed to the Procuring Entity until their receipt and final acceptance at the final destination.</p> <p>Intellectual Property Rights –</p> <p>The Supplier shall indemnify the Procuring Entity against all third-party claims of infringement of patent, trademark, or industrial design rights arising from use of the Goods or any part thereof.</p>
2.2	<p>Payment shall be made by Check for local Supplier, or through irrevocable Letter of Credit (LC) in case of foreign supplier/manufacturer.</p> <p>In case payment shall be made by LC, the Procuring Entity shall open the irrevocable LC in favor of the Supplier in accordance with the terms provided below in an Authorized Government Depository Bank after the approval of the Contract by the HOPE and cash transfer from the PA to the Authorized Government Depository Bank, to wit:</p> <ol style="list-style-type: none"> a. Mode of Transmission: Full cable telex/S.W.I.F.T; b. Advising and/or Confirmation: LC may be advised and/or confirmed by any bank to be identified by the Supplier, at the latter's sole expense; c. Payee Bank: The LC draft (if any) shall be drawn on the confirming bank; d. Beneficiary: [Insert name and address of Supplier with Point of Contact]; e. Currency and Amount of LC: LC shall be in Philippine Peso, in an amount equivalent to the Total Contract Price. The 95% of the amount of LC shall be released upon completion of all the required documents enumerated in SCC Clause 2.2 (f) of the Bidding Documents and the 5% shall be released upon expiration of the warranty period provided in SCC Clause 5.1 in the Bidding

	<p>Documents;</p> <p>f. Expiration Date: Two Hundred Eighty (280) calendar days from issue date of the L/C;</p> <p>g. The terms of payment shall be as follows: “Partial Payment” to the Supplier at the time of the partial delivery and final acceptance of the Goods by the Procuring Entity made in accordance with Section VI. Schedule of Requirements, and the submission or presentation of the following documents:</p> <ul style="list-style-type: none"> i. Supplier’s invoice showing Goods’ description, quantity, unit price, and total amount; ii. Negotiable, clean shipped on-board Bill of Lading marked “Freight Pre-Paid” and/or “Non-Negotiable Bill of Lading” or “Airway Bill”; iii. Pre-shipment inspection report by PA TIAC; iv. Manufacturer’s and/or Supplier’s warranty certificate; v. Certificate of Origin (for imported GOODS); vi. Delivery Receipt detailing number and description of items received signed by the Procuring Entity’s representative at the Delivery Site; vii. Certificate of Acceptance by the PA Technical Inspection and Acceptance Committee (PA TIAC).
<p>3</p>	<p>If the Performance Security is in the form of a Surety Bond, it must be in the name of the Philippine Army/AFP, and its validity must be until the issuance by the Procuring Entity of the Certificate of Final Acceptance. The Surety Bond must be duly notarized and signed by the Supplier's authorized representative indicating therein his/her full name.</p>
<p>4</p>	<p>The inspections and tests that will be conducted are:</p> <p>a. Post-Qualification involving documents validation, testing and/or manufacturer’s plant visit and inspection shall be conducted by the Procuring Entity or its designated representatives (PQ Team) in order to determine the compliance to the requirements of the end-user as required in the bidding documents. Expenses incurred related hereto particularly travel and board and lodging expenses shall be borne by the Procuring Entity.</p> <p>Submitted prototype/finished samples and swatches duly tested and evaluated as compliant/passed shall be the property and proper disposition of the Procuring Entity while those that were tested and evaluated as non-compliant or Post Disqualified can be retrieved by the Bidder, through an official letter request addressed to PABAC1 (Attn: Chairman, TWG), within three (3) months upon receipt of notice from PABAC1 that such Bidder was Post-Disqualified on said project, otherwise, subject prototype/finished samples and swatches shall be the property and proper disposition of the</p>

Procuring Entity.

All test that cannot be conducted in the Philippines, the Supplier shall provide a test result from reputable third-party testing facility from the country of origin.

All cost related to the testing, including the samples for random testing, shall be for the account of the bidder/supplier.

b. **Pre-Shipment/Pre-Delivery Inspection and Test:**

All Items shall be subjected to pre-shipment/ pre-delivery inspection and the test (PDI) by the Philippine Army.

1) For Goods Sourced from Abroad

i. All Items shall be subjected to pre-shipment/ pre-delivery inspection and the test (PDI) by the Philippine Army representatives. The PDI shall be conducted not later than sixty (60) days prior to the expiry of the required delivery period at the goods' country of origin.

ii. The Inspection Team to attend the pre-shipment/pre-delivery test at the country of origin at supplier's expenses shall be composed of a maximum of three (3) members who have technical knowledge to the project.

iii. The Manufacturer shall ensure that the Inspection Team will be allowed to jointly participate in the conduct of the testing procedures.

iv. All functional test should be conducted by a reputable independent third-party entity recommended by the supplier, the supplier should provide at least three (3) independent reputable third party testing centers or facilities for consideration.

v. Supplier shall shoulder all the costs and expense of travel (via/IATA member airlines in case of international travel) and accommodation including Daily Subsistence Allowance (pursuant to Section 8, EO 298) and securing visas as necessary and travel insurance of all the Inspection Team Members. In this regard, supplier is required to issue the required written invitations to the Inspection team through Philippine Army relative to the PDI within seven (7) calendar days from receipt of NTP.

vi. Supplier shall conduct product/inspection and pre-departure briefing to orient the members of the Inspection team at least one (1) week prior to departure date. Supplier shall ensure that a full time/on-board interpreter is available for non-English speaking country of manufacturer/plant site. Travel documents including insurance must be submitted to the inspection team during the pre-departure briefing.

vii. Failure to provide such invitation per paragraph *d* above may result in delays in release of required travel orders for the inspection team and may subject the supplier to applicable sanctions including liquidated damages due to late delivery.

viii. Items/Goods must comply with the required Technical Specification.

ix. All cost related to the testing, including the samples for random testing, shall be for the account of the bidder/supplier.

x. Item/s subject for destructive testing shall be included

	<p>during delivery, but shall not be counted as part of the quantity being delivered.</p> <p>2) For Goods sourced Locally:</p> <p>i. Pre-delivery inspection of the items to be conducted by Philippine Army Inspection Team at the Manufacturer’s local facilities, or at an authorized third-party testing facility.</p> <p>ii. Supplier shall shoulder all the costs and expense of travel and accommodation including Daily Subsistence Allowance and travel insurance, as necessary, of all the Inspection Team Members. In this regard, supplier is required to issue the required written invitations to the Inspection team through Philippine Army relative to the PDI within seven (7) calendar days from receipt of NTP.</p> <p>iii. All incidental and related expenses relative to inspection shall be for the account of the manufacturer/supplier.</p> <p>iv. Acceptance Tests to be conducted as per prescribed Test and Acceptance Procedures.</p> <p>v. Items/Goods must comply with the required Technical Specification.</p> <p>vi. All cost related to the testing, including the samples for random testing, shall be for the account of the bidder/supplier.</p> <p>vii. Item/s subject for destructive testing shall be included during delivery, but shall not be counted as part of the quantity being delivered.</p> <p>*Cost of testing including the cost of sample shall be for the account of the supplier. The samples shall be over and above the quantity to be delivered.</p> <p>*The PDI shall be conducted in accordance with the prescribed PA Test and Acceptance Procedures.</p> <p>c. Final Inspection and Acceptance at the Delivery Site. Completeness and appropriateness of the delivered goods shall be conducted by the Procuring Entity’s representative (PATIAC) at the delivery site. Expenses incurred related hereto particularly travel and board and lodging expenses shall be borne by the Procuring Entity.</p> <p>d. Non-Acceptance of Items - In case items are rejected, Philippine Army Technical Inspection and Acceptance Committee (PATIAC) shall issue Certificate of Non-Acceptance on the cause of non-compliance of the item. A corresponding Notice of Non-Acceptance shall then be issued by Philippine Army Procurement Center (PAPC) to the supplier further advising that the period for replacement of defective item is within thirty (30) calendar days from receipt thereof.</p> <p>Once the allowable period of replacement exceeds, the contract shall be terminated. Supplier shall be subjected to blacklisting due to termination for default.</p>
5.1	The warranty shall be covered by, either retention money or a special bank guarantee in favor of the Philippine Army equivalent to five percent (5%) of the

	<p>Contract Price. The Obligation for the warranty shall only be released after the lapse of the warranty period.</p> <p>The warranty period shall be six (6) months after acceptance by the Procuring Entity of the delivered Goods.</p> <p>The goods to be delivered must have been manufactured not more than one (1) year from the date of delivery.</p>
5.2	<p>The period for correction of defective items in the warranty period is within thirty (30) calendar days upon receipt of notice from the Procuring Entity of any claim arising from the warranty obligation of the supplier. The Procuring Entity through the TIAC may invoke for warranty claims for the Goods or any part thereof that fail to conform to the specifications within the warranty period. The Supplier shall either rectify or replace such defective Goods or parts thereof or make alterations necessary to meet the specifications at no cost to the Procuring Entity, and shall inspect the rectified/replaced goods, at no cost to the Procuring Entity, upon giving a notice pursuant to GCC Clause 5.2</p>
6	<p>If the Supplier fails to satisfactorily deliver any or all of the Goods and/or to perform the Services within the period(s) specified in this Contract inclusive of duly granted time extensions if any, the Procuring Entity shall, without prejudice to its other remedies under this Contract and under the applicable law, deduct from the Contract Price, as liquidated damages, the applicable rate of one tenth (1/10) of one (1) percent of the cost of the unperformed portion for every day of delay until actual delivery or performance. In case the total sum of liquidated damages reaches ten percent (10%) of the total contract price, the Procuring Entity concerned may rescind the contract and impose appropriate sanctions over and above the liquidated damages to be paid</p>

Section VI. Schedule of Requirements

The delivery schedule expressed as weeks/months stipulates hereafter a delivery date which is the date of delivery to the project site.

Description	Quantity	Delivery Period	Delivery Place
Tire, 425x65 R22.5	80 each	Full Delivery within two hundred fifty (250) Calendar Days upon Receipt of NTP	GS Warehouse, 1LSG, Army Support Command, PA, Camp General Servillano Aquino, San Miguel, Tarlac City
Tire, 315x80 R22.5	100 each		
Tire, 36x12.5 R16.5 LT	5,563 each		10FSSU, 2LSG, ASCOM, PA, Camp Evangelista, Patag, Cagayan de Oro City
	3,100 each		

Section VII. Technical Specifications

Army Vision: By 2028, a world-class Army that is a source of national pride.

HEADQUARTERS
PHILIPPINE ARMY
OFFICE OF THE ARMY QUARTERMASTER
Fort Andres Bonifacio, Metro Manila

PA SPECIFICATION

QM SPEC NR OE-23T36R165

MAY 30 2017
(Interim)
Supersede
SPEC NR MT06-14
Dated 03 September 2014

TIRE, 36x12.5 R16.5 LT

Application: Intended for use in Truck Light, Cargo/Troop Carrier, 1 ¼ Ton KM450, (military tactical vehicle).	
Technical Data	Requirements
Visual	
1. Type/Construction	Tubeless/Radial
2. Brand name or trade name	Identifiable
3. Nominal size including ply rating and load range	Identifiable
Tire size	36x12.5 R16.5LT
Ply rating/Load range	10PR/E (minimum)
4. Maximum air pressure	Identifiable
5. The words "Made in the Philippines" or country of origin if imported.	Identifiable
6. Maximum load capacity (kgs)	At least 1,850 @ 450 KPa
7. Manufacturing date	Identifiable
Dimensional	
8. Outer Diameter (mm)	916 ± 6
9. Sectional Width (mm)	305 ± 6
10. Tread Width (mm)	250 ± 6
Tire Strength	Must pass the plunger rod test

Note: The measuring rim width to be used during testing is 228-254mm (9" - 10").

AURELIO T BADAJOS
Colonel, QMS (GSC) PA
Chief

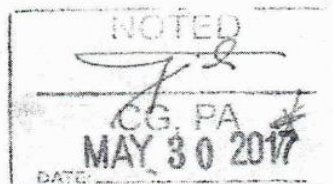

Army Core Purpose: Serving the people. Securing the land.

By 2028, a world-class Army that is a source of national pride.

HEADQUARTERS
PHILIPPINE ARMY
OFFICE OF THE ARMY CHIEF QUARTERMASTER
Fort Andres Bonifacio, Metro Manila

TEST AND EVALUATION PROCEDURE
TIRE, 36 X 12.5 R16.5 LT with QM SPEC NR OE-23T36R165 dated 30 May 2017

A. POST QUALIFICATION INSPECTION

SECTION 1A – GENERAL

1.1. **AUTHORITY:** The Test and Evaluation (T&E) is being conducted in line with the provisions of the RA 9184.

1.2. **OBJECTIVES:** The objective of this T&E is to determine the responsiveness of the Bidder with the Single/Lowest Calculated Bid (SCB/LCB) to the technical specification as endorsed by the Bids and Awards Committee (BAC).

1.3. **SCOPE:** This T&E Procedure will be conducted on the samples of TIRE, 36 X 12.5 R16.5 LT, test reports, certification and brochures submitted by the Bidder with the SCB/LCB as part of the post qualification procedure by the BAC.

1.4. **METHODOLOGY:** The tests include physical inspection and evaluation of documents that will support the compliance of the TIRE, 36 X 12.5 R16.5 LT to the specification. Records check will also be conducted as appropriate including third party publications.

1.5. **REFERENCES:**

1.5.1. Philippine National Standard for Pneumatic Tires, PNS25: 1994

1.5.2. ISO 4209-1:2001 International Standard (minimum) – Truck and Bus Tires and Rims (Metric Series)

1.6. **POST QUALIFICATION CRITERIA:** Post Qualification evaluation shall be based on a Pass (P) or Fail (F) criteria. Any major defect found shall be evaluated as "Failed" and two (2) or more minor defects found shall be evaluated as "Failed".

SECTION 2A – PROCEDURES

1. Allocation Of Samples

One (1) sample shall be submitted to undergo physical, dimensional and tire strength. Previous test results on visual, dimensional and plunger test that is within the period of three (3) years and evaluated as passed can be used in lieu of submission of required samples.

2. Physical Inspection

2.1 **Purpose:** To determine the conformance of the physical characteristics, external workmanship of the Tires to the minimum requirements of the specifications.

Page 1 of 6

Honor. Patriotism. Duty.



60
/

By 2028, a world-class Army that is a source of national pride.

2.2 Procedure:

2.2.1 Visually inspect the completeness, overall appearance and presence of the required symbols or markings on the tire sample/s.

2.2.2 Standard:

- 2.2.2.1 With the required Type/Construction
- 2.2.2.2 With the required Traction Design (Lug Type/Mud Terrain)
- 2.2.2.3 With PS or ICC Quality Mark or Certificate of Exemption from DTI in case the product offered are beyond the minimum standard of DTI
- 2.2.2.4 With Brand Name or Trade Name.
- 2.2.2.5 Tire Designation Markings: Manufacturer's Standard for Tire, 36 x 12.5 R16.5 LT. (Tire Size and Ply Rating, Load Index/Rating).
- 2.2.2.6 With Maximum Air Pressure Markings.
- 2.2.2.7 With identifiable markings for country of origin if imported
- 2.2.2.8 With Maximum Load Capacity markings.
- 2.2.2.9 With Manufacturing Date Code (within 1 year prior to delivery date)
- 2.2.2.10 No evident damage on tread, sidewall, ply, cord, inner liner and including damage on flap or tube/tube valve. No bead separation, chunking, broken cords, cracking or open splices.

3. Dimensional Test

3.1 Purpose: To determine the actual dimensions of the tire sample/s.

3.2 Procedure:

3.2.1 The tire set sample/s shall be mounted on its corresponding rim (228mm to 254mm width) and inflated to the indicated maximum permissible inflation pressure at maximum load as labeled on the tire sidewall. The tire shall be allowed to stand for a minimum of 24 hours at room temperature. The pressure thereafter should be measured and adjusted to within 10kPa of the pressure specified for the tire type, being the ideal condition for measurement of the tire. Measure the Overall Diameter, Overall Width and Size Factor by hanging the tire to avoid any obstruction from any external factor which may affect the dimensional test.

3.2.2 Outer Diameter shall be determined to the nearest millimeter by measuring the outside circumference by a tape and then divide the value by constant 3.1416 (π). or by means of a measuring device calibrated to show directly the diameter of the tire.

3.2.3 Sectional Width is the average of maximum widths including the sidewalls, side ribs, bars decorations, letters or numerals. The width shall be measured by nearest millimeters at four different points equally distributed around the tire and the result averaged.

3.2.4 Thread Width shall be measured in the internationally accepted "Thread Design Guide" or if not indicated, it is the distance between the two outer edges of a tire's thread.

Page 2 of 6

Honor. Patriotism. Duty.



60

r

By 2028, a world-class Army that is a source of national pride.

3.2.5 Standard:

Parameters	Traction Design
Overall Diameter (mm)	916 (± 6)
Section Width (mm)	305 (± 6)
Thread Width (mm)	250(± 6)

4. Tire Strength Test

4.1 Purpose: To determine the strength of the tire

4.2 Procedure:

4.2.1 To be conducted by Philippine Geo Analytics Inc. (PGAI) if done in-Country or equivalent government recognized testing center at the country of origin.

4.2.2 Force a required cylindrical steel plunger rod with a hemispherical end at 5 equally distributed points perpendicularly into the tread rib as near to the centerline as possible, avoiding penetration into the groove, at the rate of 50 mm/min±10 mm/min.

4.2.3 The plunger is stopped before reaching the rim or the standard required tire strength value is reached without the tire breaking.

4.2.4 Standard: Tire Strength requirement based on PNS 25:1994 standards if done in-Country or its equivalent standard used at the country of origin if conducted thereat.

B. PRE-DELIVERY INSPECTION

SECTION 1B – GENERAL

1.1. AUTHORITY: The Test and Evaluation (T&E) is being conducted in line with the provisions of the RA 9184.

1.2. OBJECTIVES: The objective of this T&E is to determine the compliances to the technical specification of the samples selected at random during Pre-delivery Inspection (PDI).

1.3. SCOPE: This T&E Procedure will be conducted on the samples of TIRE, 36 X 12.5 R16.5 LT taken at random by the PDI Team.

1.4. METHODOLOGY: The tests include physical inspection, dimensional, strength test and evaluation of documents that will support the compliance of the TIRE, 36 X 12.5 R16.5 LT to the specification. Records check will also be conducted as appropriate including third party publications.

SECTION 2B – PROCEDURES

2.1. The Pre-Delivery Inspection (PDI) Team or its representatives shall ensure that the complete quantity stated in the contract is packed/palletized prior to inspection.



6a

By 2028, a world-class Army that is a source of national pride.

- 2.2. The PDI team shall conduct random sampling from the lot or lots. The samples shall be properly segregated, packed, marked and secured by the members/representatives of the committee.
- 2.3. Technical inspection and test shall be conducted on the representative samples of the lot by visual, dimensional and functional test to determine the over-all workmanship, markings, size and appropriate packaging of the items.
- 2.4. Functional Test will be done to determine the functional performance of the tire.
- 2.5. Results obtained shall be recorded and evaluated to determine the compliance of the items to Technical Specifications and as basis for acceptance or rejection of the lot or lots.

SECTION 3B - TEST PARAMETERS

1. Allocation Of Samples

Two (2) samples shall be picked at random from the delivery to undergo tire strength. If one (1) tire fails on the strength test, the other one may be substituted to the failed tire. Number of samples to be selected for Visual Inspection shall be based on Mil Std 105E dated 10 May 1989.

2. Physical Inspection

2.1 Purpose: To determine the conformance of the physical characteristics, external workmanship of the Tires to the minimum requirements of the specifications.

2.2 Procedure:

2.2.1 Visually inspect the completeness, overall appearance and presence of required symbols or markings of the on the tire sample/s.

2.2.2 Standard

- 2.2.2.1 With the required Traction Design (Lug Type/Mud Terrain)
- 2.2.2.2 With Brand Name or Trade Name.
- 2.2.2.3 Tire Designation Markings: Manufacturer's Standard for Tire, 36 x 12.5 R16.5 LT. (Tire Size and Ply Rating, Load Index/Rating).
- 2.2.2.4 With Maximum Air Pressure Markings.
- 2.2.2.5 With identifiable markings for country of origin if imported
- 2.2.2.6 With Manufacturing Date Code (within 1 year prior to delivery date)
- 2.2.2.7 No evident damage on tread, sidewall, ply, cord, inner liner and including damage on flap or tube/tube valve. No bead separation, chunking, broken cords, cracking or open splices.

3. Dimensional Test

3.1 Purpose: To determine the actual dimensions of the tire sample/s

Page 4 of 6

Honor. Patriotism. Duty.



6a

[Handwritten signature]

By 2028, a world-class Army that is a source of national pride.

3.2 Procedure:

3.2.1 The tire set sample/s shall be mounted on its corresponding rim (228mm to 254mm width) and inflated to the indicated maximum permissible inflation pressure at maximum load as labeled on the tire sidewall. The tire shall be allowed to stand for a minimum of 24 hours at room temperature. The pressure thereafter should be measured and adjusted to within 10kPa of the pressure specified for the tire type, being the ideal condition for measurement of the tire. Measure the Overall Diameter, Overall Width and Size Factor by hanging the tire to avoid any obstruction from any external factor which may affect the dimensional test.

3.2.2 Outer Diameter shall be determined to the nearest millimeter by measuring the outside circumference by a tape and then divide the value by constant 3.1416 (π), or by means of a measuring device calibrated to show directly the diameter of the tire.

3.2.3 Sectional Width is the average of maximum widths including the sidewalls, side ribs, bars decorations, letters or numerals. The width shall be measured by nearest millimeters at four different points equally distributed around the tire and the result averaged.

3.2.4 Thread Width shall be measured in the internationally accepted "Thread Design Guide" or if not indicated, it is the distance between the two outer edges of a tire's thread.

3.2.5 Standard:

Parameters	Traction Design
Overall Diameter (mm)	916 (± 6)
Section Width (mm)	305 (± 6)
Thread Width (mm)	250 (± 6)

4. Tire Strength Test

4.1 Purpose: To determine the strength of the tire

4.2 Procedure:

4.2.1 To be conducted by Philippine Geo Analytics Inc (PGAI) if done in-Country or equivalent government recognized testing center at the country of origin.

4.2.2 Force a required cylindrical steel plunger rod with a hemispherical end at 5 equally distributed points perpendicularly into the tread rib as near to the centerline as possible, avoiding penetration into the groove, at the rate of 50 mm/min \pm 10 mm/min.

4.2.3 The plunger is stopped before reaching the rim or the standard required tire strength value is reached without the tire breaking.

4.2.4 Standard: Tire Strength requirement based on PNS 25:1994 standards if done in-Country or its equivalent standard used at the country of origin if conducted thereat.



ba

By 2028, a world-class Army that is a source of national pride.

C. FINAL INSPECTION

SECTION 1C - GENERAL

- 1.1. **AUTHORITY:** The Test and Evaluation (T&E) is being conducted in line with the provisions of the RA 9184.
- 1.2. **OBJECTIVES:** The objective of this procedure is to ensure the completeness of the delivery site and that the items delivered are the one and the same from those that were inspected during the Pre-delivery inspection.
- 1.3. **SCOPE:** This procedure will be conducted on the delivered TIRES, 36 X 12.5 R16.5 LT which were previously inspected during the Pre-delivery inspection.
- 1.4. **METHODOLOGY:** The procedure will involve visual inspection and accounting of the completeness of the item delivered.
- 1.5. **Samples:** 100% of items delivered
- 1.6. The result of the test based on the above criteria shall be the basis for evaluation of the Acceptance Committee in the acceptance/rejection of the above item for use of the PA.

SECTION 2C – PROCEDURES

1. Physical Count

To determine the completeness of the items delivered, its consistency of the items inspected during Pre-Delivery Inspection vis-à-vis the actual tires delivered, and physical state of the delivered items.

2. Procedure:

- 2.1. Account for the completeness (quantity) of the tires delivered including its required size of flaps and tubes.
- 2.2. Visually inspect the physical state of the delivered items.
- 2.3. With PS or ICC Quality Mark or Certificate of Exemption from DTI in case the product offered are beyond the minimum standard of DTI

3. Standard

- 3.1. The total tires delivered shall be complete in quantity based on the contract.
- 3.2. There shall be no damaged that could affect the functionality and appearance of the delivered items.

Prepared by:

GENERAL C. CONTILLO
 Major (QMS) PA
 Plans & Research Branch

Approved by:

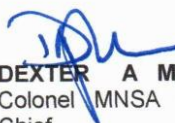
DEXTER A. MACASAET
 Colonel MNSA (QMS) PA
 Chief

Page 6 of 6

Honor. Patriotism. Duty.



TEST PARAMETERS
TECHNICAL SPECIFICATIONS FOR
TIRE, 36x12.5 R16.5 LT

DEFECTS	CLASSIFICATION OF DEFECTS	
	MAJOR	MINOR
Visual		
1. Without the Tire's Flap and Tube as required	x	
2. Not the required Traction Design (Directional/Rib or Lug Type as appropriate)	x	
3. Without PS or ICC Quality Mark or DTI Exemption Certificate	x	
4. Without Brand Name or Trade Name markings	x	
5. Without Manufacturer's Tire Designation Markings for 36x12.5 R16.5 LT.	x	
6. Not within the Minimum Load Range and/or Ply Rating and Type/Construction requirements	x	
7. Without Maximum Air Pressure Markings	x	
8. Without the words "Made in the Philippines" or country of origin if imported.	x	
9. Without Manufacturing Date Mark/Symbol	x	
10. Not within the Manufacturing Period requirement	x	
11. Without Maximum Load Capacity Markings	x	
12. Not within the Maximum Load Capacity Requirement	x	
13. Evident damage on Tread or Sidewall or Ply or Cord or Inner liner	x	
14. Evident damage on Flap or Tube/Tube valve	x	
15. Bead Separation	x	
16. Chunking or Cracking or Open Splices on tire surface	x	
Dimensional Test		
17. Dimensions (Diameter or Width or Tread Depth) is not within the standard requirement		x
18. Size Factor is not within the standard requirement	x	
Workmanship		
19. Does not affect appearance		x
20. Affect appearance	x	
Tire Strength		
21. Did not meet the required tire strength	x	
Total test point	19	2

 AURELIO T. BADAJOS
 Colonel, QMS (GSC) PA
 Chief

Army Vision: By 2028, a world-class Army that is a source of national pride.

HEADQUARTERS
PHILIPPINE ARMY
OFFICE OF THE ARMY CHIEF QUARTERMASTER
Fort Andres Bonifacio, Metro Manila

PA SPECIFICATION

SPEC NR OE-23T425x65 R22.5

09 AUG 2019
(Interim)**TIRE, 425x65 R22.5**

Application: Intended for use in Trucks and Trailers	
Technical Data	Requirements
Design:	
1. Traction Design	Rib Type
2. Type/ Construction	Tubeless/Radial
Construction:	Bead, Inner Liner, 1 st Ply, 2 nd Ply, Tread, 1 st Belt, 2 nd Belt and Side Wall
Composition:	Natural Rubber
	Synthetic Rubber
	Carbon Black
	Steel
Fibre, Fillers, Accelerators, antiozonants, etc	
Markings:	
1. Manufacturer's Tire Designation Markings	425x65 R22.5
2. Minimum ply rating/Load range	20 ply/Load Range L
3. Country of origin if imported	Philippines/Country of origin
4. Manufacturing date/Symbol	Coded by Week/Year
5. Manufacturing Period requirement	Date covered is within six (6) month prior to delivery period
Maximum load capacity (at 827 kPa):	
Maximum load single (kgs)	At least 5150
Dimensional Test:	
1. Section Width (mm)	430 (maximum)
2. Overall Diameter (mm)	1150 (maximum)
3. Overall Width (mm)	16 (maximum)
Tire strength:	Min 2203J @ 50mm/min ± 10mm/min
Workmanship manufacturing standard:	Tech Specs Compliant
Packaging:	Each tire shall be packed in transparent plastic or manufacturer standard.

EDMUNDO S. SUFICIENCIA
Colonel, GSC (QMS) PA
Chief

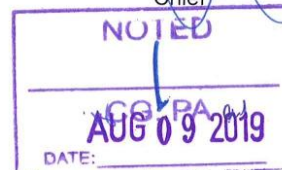

Army Core Purpose: Serving the people. Securing the land.

2028, a world-class Army is a source of national pride.

HEADQUARTERS
PHILIPPINE ARMY
OFFICE OF THE ARMY CHIEF QUARTERMASTER

PA SPECIFICATION

SPEC NR OE-23T425x65 R22.5
09 AUG 2019
(Interim)

TIRE, 425x65 R22.5

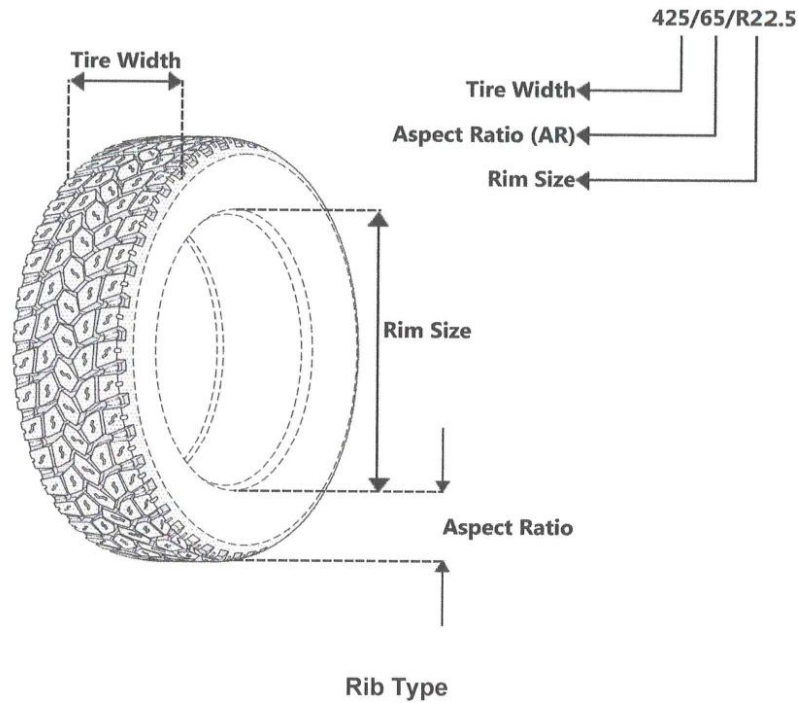

FIGURE 1

Honor. Patriotism. Duty.



Army Vision: By 2028, a world-class Army that is a source of national pride.

HEADQUARTERS
PHILIPPINE ARMY
OFFICE OF THE ARMY CHIEF QUARTERMASTER
Fort Andres Bonifacio, Metro Manila

TEST AND ACCEPTANCE PROCEDURE
TIRE, 425x65 R22.5

1. GENERAL

1.1. Scope: This Test and Acceptance Procedure shall apply to 425x65 R22.5 Tires intended for Trucks and Trailers vehicles.

1.2. Objective: To ascertain compliance of tires with standards and specifications in consonance with the need of the end user.

1.3. References:

- a. Philippine National Standard for Pneumatic Tires, PNS 25: 1994.
- b. ISO 4209-1:2001 International Standard – Truck and Bus Tires and Rims (Metric Series)

2. PROCEDURES

2.1. The Technical Inspection and Acceptance Committee (TIAC) for Quartermaster Items or its representatives shall ensure that the complete quantity stated in the contract is packed/palletized prior to inspection.

2.2. The TIAC shall conduct random sampling from the lot or lots. The samples shall be properly segregated, packed, marked and secured by the members/representatives of the committee.

2.3. Technical inspection and test shall be conducted on the representative samples of the lot by visual, dimensional and functional test to determine the over-all workmanship, markings, size and appropriate packaging of the items.

2.4. Functional Test will be done to determine the functional performance of the tire.

2.5. Results obtained shall be recorded and evaluated to determine the compliance of the items to Technical Specifications and as basis for acceptance or rejection of the lot or lots.

3. PHYSICAL INSPECTION

3.3. Visual Inspection

3.3.1. Purpose: To determine the completeness, overall external workmanship, symbols, codes and markings of the tire set sample/s.

3.3.2. Procedure: Visually inspect the completeness, overall appearance and presence of required symbols or markings of the tire set.

Page 1 of 4

Army Core Purpose: Serving the people. Securing the land.

Army Vision: By 2028, a world-class Army that is a source of national pride.

3.3.3. Standard:

- 3.3.3.1. With the Tires required appropriate size of Flap and Tube.
- 3.3.3.2. With the required Traction Design (Rib Type as appropriate)
- 3.3.3.3. With PS or ICC Quality Mark or Certificate of Exemption from DTI in case the product offered are beyond the minimum standard of DTI.
- 3.3.3.4. With Brand Name or Trade Name.
- 3.3.3.5. Tire Designation Markings: Manufacturer's Standard for Tire, 425x65 R22.5 (Tire Size, Minimum Ply Rating/Load Range and Type/Construction).
- 3.3.3.6. With Maximum Air Pressure Markings.
- 3.3.3.7. With the words "Made in the Philippines" or country of origin if imported.
- 3.3.3.8. With Manufacturing Date Markings.
- 3.3.3.9. With Maximum Load Capacity Markings.
- 3.3.3.10. No evident damage on tread, sidewall, ply, cord, inner liner and including damage on flap and tube/tube valve. No bead separation, chunking, broken cords, cracking or open splices.

3.4. Dimensional Test

3.4.1. Purpose: To determine the actual dimensions of the tire sample/s.

3.4.2. Procedure:

3.4.2.1. The tire set sample/s shall be mounted on its corresponding rim and inflated to the indicated maximum permissible inflation pressure (827kPa) at maximum load as labeled on the tire sidewall. The tire shall be allowed to stand for a minimum of 24 hours at room temperature. The pressure thereafter should be measured and adjusted to within 10kPa of the pressure specified for the tire type, being the ideal condition for measurement of the tire. Measure the Overall Diameter, Overall Width and Size Factor by hanging the tire to avoid any obstruction from any external factor which may affect the dimensional test.

3.4.2.2. Overall Diameter shall be determined to the nearest millimeter by measuring the outside circumference by a tape and then divide the value by constant 3.1416 (π). or by means of a measuring device calibrated to show directly the diameter of the tire. Figure 1, 2 and 3.

3.4.2.3. Overall Width is the average of maximum widths including the sidewalls, side ribs, bars decorations, letters or numerals. The width shall be measured by nearest millimeters at four different points equally distributed around the tire and the result averaged.

Page 2 of 4

Army Core Purpose: Serving the people. Securing the land.

Army Vision: By 2028, a world-class Army that is a source of national pride.

3.4.2.4. Size Factor shall be the sum of overall diameter and overall width.

3.4.3. Standard:

Parameters	Traction Design
Size Factor (mm)	1515 (minimum)
Overall Tire Width (mm)	430 (maximum)
Overall Diameter (mm)	1150 (maximum)
Thread Depth (mm)	Rib Type 16 (minimum)

3.5. Tire Strength Test

3.3.1 Purpose: To determine the strength of the tire.

3.3.2 Allocation of samples

3.3.2.1 Post Qualification: One (1) sample shall be submitted to undergo the plunger test. Previous test result of plunger test that is within the period of one (1) year and evaluated as passed can be used in lieu of submission of required samples.

3.3.2.2 Pre Delivery/Final Acceptance: One (1) sample shall be subjected to plunger test that will be taken at random from the delivery which had already undergone the physical inspection and dimensional test. Additional sample for plunger test will be provided when prescribed in the contract which will be determined by procuring entity's representative.

3.3.3 Procedure:

3.3.3.2 To be conducted by Philippine GeoAnalytics Inc (PGAI) if done in-Country or equivalent government recognized testing center at the country of origin.

3.3.3.3 Force a 38mm diameter cylindrical steel plunger rod with a hemispherical end at 5 equally distributed points perpendicularly into the tread rib as near to the centerline as possible, avoiding penetration into the groove, at the rate of 50 mm/min \pm 10 mm/min.

3.3.3.4 The plunger is stopped before reaching the rim or the required tire strength value of 2203J is reached without the tire breaking.

3.3.3.5 Should there be a Pre Delivery Inspection at the country of origin, all the required Functional Tests and Inspections shall be conducted through a capable independent third party entity or that host country/government accredited test facility or in the absence thereof, at the manufacturer's test facilities. The Manufacturer shall issue a document certifying that the tested tire came from the lots delivered and have passed the Tire Strength Test.

3.3.4 Standard: Tire Strength requirement based on PNS 25:1994 standards if done in-Country or its equivalent standard used at the country of origin if conducted thereat.

Page 3 of 4

Army Core Purpose: Serving the people. Securing the land.

Army Vision: By 2028, a world-class Army that is a source of national pride.

3.3.4.1 All tire samples must pass the test. Any samples that fail the tire strength test shall cause the rejection of the lot.

4. ACCEPTABILITY

4.1 The result of the test based on the above criteria shall be the basis for evaluation of the Acceptance Committee in the acceptance/rejection of the above item for use of the PA.

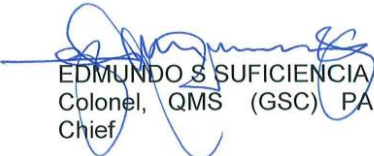
EDMUNDO S. SUFICIENCIA
Colonel, QMS (GSC) PA
Chief

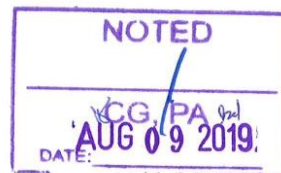

Page 4 of 4

Army Core Purpose: Serving the people. Securing the land.

**TABLE OF CLASSIFICATION OF DEFECTS
TIRE, 425x85 R21**

DEFECTS	CLASSIFICATION OF DEFECTS	
	Major	Minor
Visual		
1. Without the required Flap and Tube	x	
2. Not an All-Terrain Tire	x	
3. Construction is not Radial	x	
4. Not Lug Type (Tread Pattern)	x	
5. Without PS or ICC Quality Mark or Certificate of Exemption from DTI in case the product offered are beyond the minimum standard of DTI	x	
6. Does not have Brand Name or Trade Name markings	x	
7. Does not have Manufacturer's Tire Designation Markings: 425x85 R21	x	
8. Not within the Minimum Load Index/Rating	x	
9. Not within the Minimum Speed Rating of "G" or "J" that is 100km/h equivalent	x	
10. Not within the Minimum Ply Rating	x	
11. Does not have Maximum Air Pressure Markings	x	
12. Does not have country of origin markings	x	
13. Does not have Manufacturing Date Code	x	
14. Not within the manufacturing period requirement	x	
Dimensional Test		
15. Dimensions (Diameter or Width or Tread Depth) is not within the standard requirement	x	
Workmanship		
16. Presence of dirt and stains:		
a. Does not affect appearance		x
b. Affect over-all appearance	x	
17. The tire does not suit and fit to the intended application, with obstruction, and hampers the operational function of the vehicle, like:		
a. Evident damage on Tread or Sidewall or Ply or Cord or Inner liner	x	
b. Evident damage on Flap or Tube/Tube valve	x	
c. Bead Separation	x	
d. Chunking, Broken Cords, Cracking or Open Splices on tire surface	x	
Tire Strength		
18. Failed to meet the required tire strength	x	
Packing and Packaging:		
19. Each Tire shall be packed in plastic transparent or manufacturer's standard		x
Total test point	21	2

Army Vision: By 2028, a world-class Army that is a source of national pride.

CORRECTED COPY DESTROY ALL OTHERS

HEADQUARTERS
PHILIPPINE ARMY
OFFICE OF THE ARMY CHIEF QUARTERMASTER
Fort Andres Bonifacio, Metro Manila

PA SPECIFICATION

SPEC NR OE-23T315x80 R22.5

09 AUG 2019
(Interim)

TIRE, 315x80 R22.5

Application: Intended for use in Trucks, Buses and Trailers	
Technical Data	Requirements
Design:	
1. Traction Design	Directional/Rib/Lug type
2. Type/ Construction	Tubeless/Radial
Construction:	
	Bead, Inner Liner, 1 st Ply, 2 nd Ply, Tread, 1 st Belt, 2 nd Belt and Side Wall
Composition:	
	Natural Rubber
	Synthetic Rubber
	Carbon Black
	Steel
	Fibre, Fillers, Accelerators, antiozonants, etc
Markings:	
1. Manufacturer's Tire Designation Markings	315x80 R22.5
2. Minimum ply rating/Load range	18 ply/Load Range J
3. Country of origin if imported	Philippines/Country of origin
4. Manufacturing date/Symbol	Coded by Week/Year
5. Manufacturing Period requirement	Date covered is within six (6) month prior to delivery period
Maximum load capacity (at 896 kPa):	
Maximum load single (kgs)	At least 4125
Maximum load double (kgs)	At least 3750
Dimensional Test:	
1. Section Width (mm)	325 (maximum)
2. Overall Diameter (mm)	1115 (maximum)
3. Overall Width (mm)	
	Directional Type 15 (maximum)
	Lug Type 20 (maximum)
Tire strength:	
	Min 2203J @ 50mm/min ± 10mm/min
Workmanship manufacturing standard:	
	Tech Specs Compliant
Packaging:	
	Each tire shall be packed in transparent plastic or manufacturer standard.

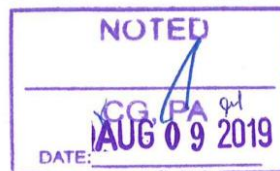

EDMUNDO S SUFICIENCIA
Colonel, GSC (QMS) PA
Chief



Honor. Patriotism. Duty.

By 2028, a world-class Army is a source of national pride.

HEADQUARTERS
PHILIPPINE ARMY
OFFICE OF THE ARMY CHIEF QUARTERMASTER

PA SPECIFICATION

SPEC NR OF-23T315x80 R22.5
09 AUG 2019
(Interim)

TIRE, 315x80 R22.5

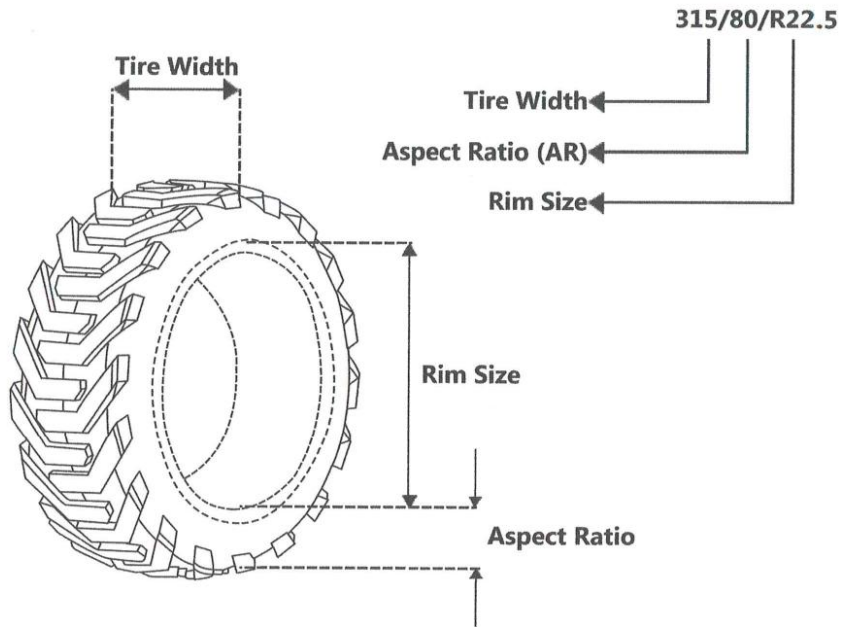

Lug Type

FIGURE 1

Page 1 of 2
Honor. Patriotism. Duty.



2028, a world-class Army is a source of national pride.

HEADQUARTERS
PHILIPPINE ARMY
OFFICE OF THE ARMY CHIEF QUARTERMASTER

PA SPECIFICATION

SPEC NR OE-23T315x80 R22.5
09 AUG 2019
(Interim)

TIRE, 315x80 R22.5

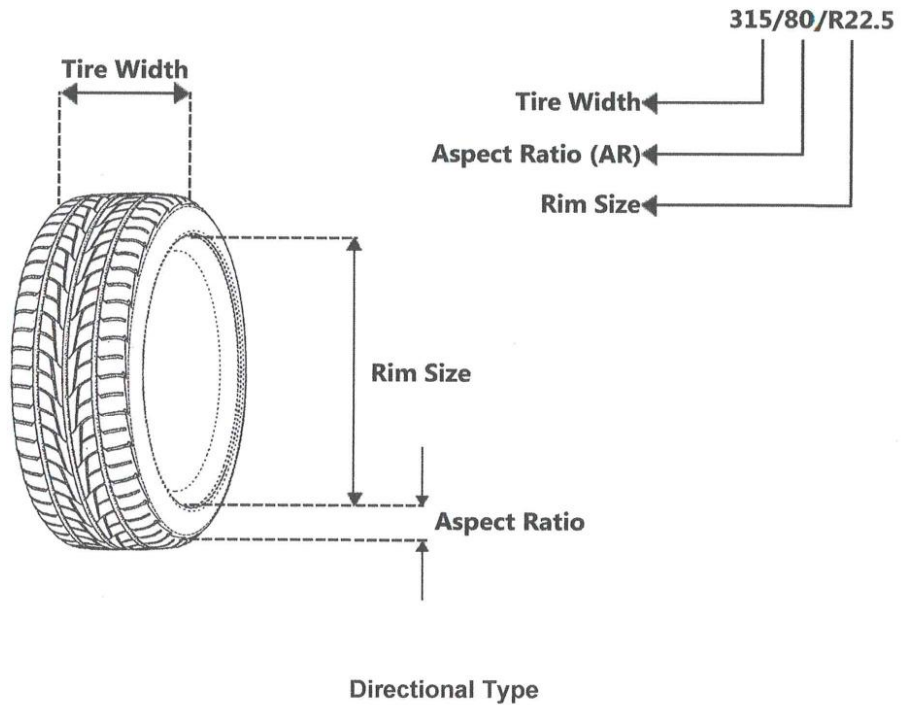

FIGURE 2



2028, a world-class Army is a source of national pride.

HEADQUARTERS
PHILIPPINE ARMY
OFFICE OF THE ARMY CHIEF QUARTERMASTER

PA SPECIFICATION

SPEC NR OE-23T315x80 R22.5

09 AUG 2019

(Interim)

TIRE, 315x80 R22.5

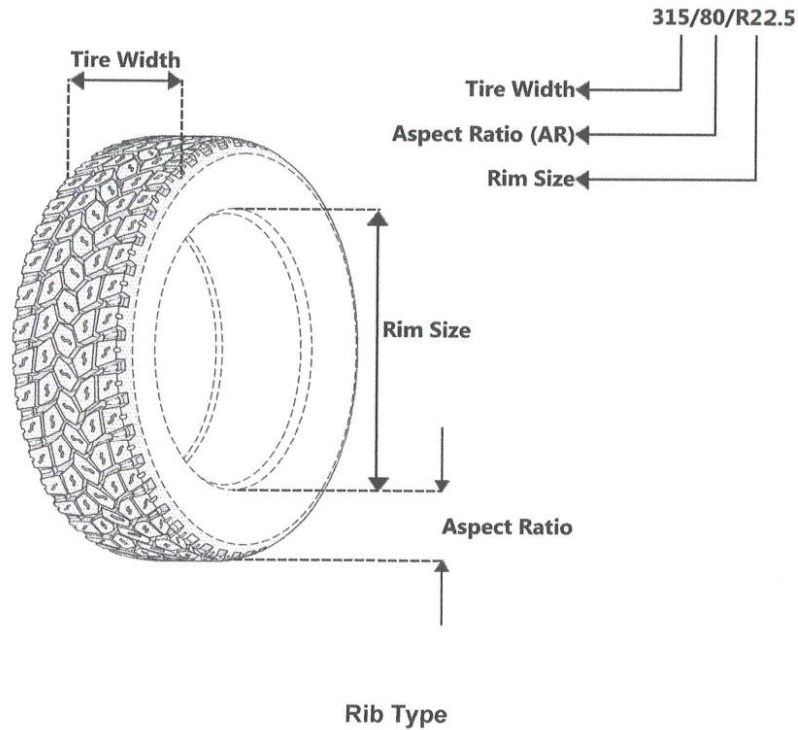

FIGURE 3



Army Vision: By 2028, a world-class Army that is a source of national pride.

HEADQUARTERS
PHILIPPINE ARMY
OFFICE OF THE ARMY CHIEF QUARTERMASTER
Fort Andres Bonifacio, Metro Manila

TEST AND ACCEPTANCE PROCEDURE
TIRE, 315x80 R22.5

1. GENERAL

1.1. Scope: This Test and Acceptance Procedure shall apply to 315x80 R22.5 Tires intended for Trucks, Buses and Trailers vehicles.

1.2. Objective: To ascertain compliance of tires with standards and specifications in consonance with the need of the end user.

1.3. References:

- a. Philippine National Standard for Pneumatic Tires, PNS 25: 1994.
- b. ISO 4209-1:2001 International Standard – Truck and Bus Tires and Rims (Metric Series)

2. PROCEDURES

2.1. The Technical Inspection and Acceptance Committee (TIAC) for Quartermaster Items or its representatives shall ensure that the complete quantity stated in the contract is packed/palletized prior to inspection.

2.2. The TIAC shall conduct random sampling from the lot or lots. The samples shall be properly segregated, packed, marked and secured by the members/representatives of the committee.

2.3. Technical inspection and test shall be conducted on the representative samples of the lot by visual, dimensional and functional test to determine the over-all workmanship, markings, size and appropriate packaging of the items.

2.4. Functional Test will be done to determine the functional performance of the tire.

2.5. Results obtained shall be recorded and evaluated to determine the compliance of the items to Technical Specifications and as basis for acceptance or rejection of the lot or lots.

3. PHYSICAL INSPECTION

3.3. Visual Inspection

3.3.1. Purpose: To determine the completeness, overall external workmanship, symbols, codes and markings of the tire set sample/s.

3.3.2. Procedure: Visually inspect the completeness, overall appearance and presence of required symbols or markings of the tire set.

Page 1 of 4

Army Core Purpose: Serving the people. Securing the land.

Army Vision: By 2028, a world-class Army that is a source of national pride.

3.3.3. Standard:

- 3.3.3.1. With the Tires required appropriate size of Flap and Tube.
- 3.3.3.2. With the required Traction Design (Directional/Rib/Lug Type as appropriate)
- 3.3.3.3. With PS or ICC Quality Mark or Certificate of Exemption from DTI in case the product offered are beyond the minimum standard of DTI.
- 3.3.3.4. With Brand Name or Trade Name.
- 3.3.3.5. Tire Designation Markings: Manufacturer's Standard for Tire, 315x80 R22.5 (Tire Size, Minimum Ply Rating/Load Range and Type/Construction).
- 3.3.3.6. With Maximum Air Pressure Markings.
- 3.3.3.7. With the words "Made in the Philippines" or country of origin if imported.
- 3.3.3.8. With Manufacturing Date Markings.
- 3.3.3.9. With Maximum Load Capacity Markings.
- 3.3.3.10. No evident damage on tread, sidewall, ply, cord, inner liner and including damage on flap and tube/tube valve. No bead separation, chunking, broken cords, cracking or open splices.

3.4. Dimensional Test

- 3.4.1. Purpose: To determine the actual dimensions of the tire sample/s.
- 3.4.2. Procedure:
 - 3.4.2.1. The tire set sample/s shall be mounted on its corresponding rim and inflated to the indicated maximum permissible inflation pressure (896kPa) at maximum load as labeled on the tire sidewall. The tire shall be allowed to stand for a minimum of 24 hours at room temperature. The pressure thereafter should be measured and adjusted to within 10kPa of the pressure specified for the tire type, being the ideal condition for measurement of the tire. Measure the Overall Diameter, Overall Width and Size Factor by hanging the tire to avoid any obstruction from any external factor which may affect the dimensional test.
 - 3.4.2.2. Overall Diameter shall be determined to the nearest millimeter by measuring the outside circumference by a tape and then divide the value by constant 3.1416 (π), or by means of a measuring device calibrated to show directly the diameter of the tire. Figure 1, 2 and 3.
 - 3.4.2.3. Overall Width is the average of maximum widths including the sidewalls, side ribs, bars decorations, letters or numerals. The width shall be measured by nearest millimeters at four different points equally distributed around the tire and the result averaged.

Page 2 of 4

Army Core Purpose: Serving the people. Securing the land.

Army Vision: By 2028, a world-class Army that is a source of national pride.

3.4.2.4. Size Factor shall be the sum of overall diameter and overall width.

3.4.3. Standard:

Parameters	Traction Design
Size Factor (mm)	1350 (minimum)
Overall Tire Width (mm)	325 (maximum)
Overall Diameter (mm)	1115 (maximum)
Thread Depth (mm)	Directional/Rib Type 15 (minimum) Lug Type 20 (minimum)

3.5. Tire Strength Test

3.3.1 Purpose: To determine the strength of the tire.

3.3.2 Allocation of samples

3.3.2.1 Post Qualification: One (1) sample shall be submitted to undergo the plunger test. Previous test result of plunger test that is within the period of one (1) year and evaluated as passed can be used in lieu of submission of required samples.

3.3.2.2 Pre Delivery/Final Acceptance: One (1) sample shall be subjected to plunger test that will be taken at random from the delivery which had already undergone the physical inspection and dimensional test. Additional sample for plunger test will be provided when prescribed in the contract which will be determined by procuring entity's representative.

3.3.3 Procedure:

3.3.3.2 To be conducted by Philippine GeoAnalytics Inc (PGAI) if done in-Country or equivalent government recognized testing center at the country of origin.

3.3.3.3 Force a 38mm diameter cylindrical steel plunger rod with a hemispherical end at 5 equally distributed points perpendicularly into the tread rib as near to the centerline as possible, avoiding penetration into the groove, at the rate of 50 mm/min±10 mm/min.

3.3.3.4 The plunger is stopped before reaching the rim or the required tire strength value of 2203J is reached without the tire breaking.

3.3.3.5 Should there be a Pre Delivery Inspection at the country of origin, all the required Functional Tests and Inspections shall be conducted through a capable independent third party entity or that host country/government accredited test facility or in the absence thereof, at the manufacturer's test facilities. The Manufacturer shall issue a document certifying that the tested tire came from the lots delivered and have passed the Tire Strength Test.

3.3.4 Standard: Tire Strength requirement based on PNS 25:1994 standards if done in-Country or its equivalent standard used at the country of origin if conducted thereat.

Army Vision: By 2028, a world-class Army that is a source of national pride.

3.3.4.1 All tire samples must pass the test. Any samples that fail the tire strength test shall cause the rejection of the lot.

4. ACCEPTABILITY

4.1 The result of the test based on the above criteria shall be the basis for evaluation of the Acceptance Committee in the acceptance/rejection of the above item for use of the PA.

EDMUNDO S SUFICIENCIA
Colonel, QMS (GSC) PA
Chief

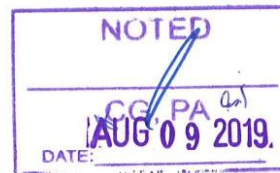

Page 4 of 4

Army Core Purpose: Serving the people. Securing the land.

DEFECTS	CLASSIFICATION OF DEFECTS	
	Major	Minor
Visual		
1. Each Tires required appropriate size Flap and Tube	x	
2. Required Traction Design (Directional/Rib or Lug Type as appropriate)	x	
3. With PS or ICC Quality Mark or Certificate of Exemption from DTI in case the product offered are beyond the minimum standard of DTI.	x	
4. Shall have Brand Name or Trade Name markings	x	
5. Manufacturer's Tire Designation Markings is 315x80 R22.5	x	
6. Not within the Minimum Load Range and/or Ply Rating and Type/Construction requirements	x	
7. Shall have Maximum Air Pressure Markings	x	
8. Shall have the words "Made in the Philippines" or country of origin if imported.	x	
9. Shall have Manufacturing Date Markings/Symbol	x	
10. Not within the Manufacturing Period requirement	x	
11. Each Tires shall have Maximum Load Capacity Markings	x	
12. Not within the Maximum Load Capacity Requirement	x	
13. Evident damage on Tread or Sidewall or Ply or Cord or Inner liner	x	
14. Evident damage on Flap or Tube/Tube valve	x	
15. Bead Separation	x	
16. Chunking, Broken Cords, Cracking or Open Splices on tire surface	x	
Dimensional Test		
17. Dimensions (Diameter or Width or Tread Depth) is not within the standard requirement		x
18. Size Factor is not within the standard requirement	x	
Workmanship		
19. Presence of dirt, stains and other defects:		
a. Does not affect appearance		x
b. Affect appearance	x	
Tire Strength		
20. Did not meet the required tire strength	x	
Packing and Packaging:		
21. Each Tire shall be packed in plastic transparent or manufacturer's standard	x	
Total test point	20	2

Section VIII. Checklist of Technical and Financial Documents

I. TECHNICAL COMPONENT ENVELOPE	
<i>Class "A" Documents</i>	
TAB	<i>Legal Documents</i>
A	<p>Valid and updated PhilGEPS Registration Certificate (Platinum Membership) in accordance with Section 8.5.2 of the revised IRR of RA No. 9184 (updated 19 July 2024) and GPPB Resolution 15 - 2021 dated 14 October 2021.</p>
<i>Technical Documents</i>	
B	<p>Duly signed Statement of the prospective bidder of all its ongoing government and private contracts, including contracts awarded but not yet started, if any, whether similar or not similar in nature and complexity to the contract to be bid. (Annex 1)</p> <p>*The bidder may make a reservation under oath in a notarized document not to disclose the name of its client on the ground of an existing confidentiality agreement but must disclose the amount, status, and name of the project for purposes of validating the NFCC, subject to the full disclosure during post-qualification. In this connection, the bidder may keep the name of the client from the statement of ongoing contracts.</p>
C	<p>Statement of the bidder's Single Largest Completed Contract (SLCC) of similar nature within the last five (5) years from the date of the Receipt and Opening of Bid Envelope.</p> <p>Pursuant to Section 23.4.1.3 of the 2016 revised IRR of RA No.9184, the Bidder shall have an SLCC that is at least one (1) contract similar to the Project the value of which, adjusted to current prices using the PSA's CPI, must be at least equivalent to at least twenty-five percent (25%) of the ABC (Expendable Supplies).</p> <p>* For this project, "similar contract or project" shall pertain to the Supply and Delivery of "any pneumatic tires".</p>
<i>Financial Documents</i>	
D	<p>The prospective bidder's computation of Net Financial Contracting Capacity (NFCC)(Annex 3-A); or</p> <p>A Committed Line of Credit from a Universal or Commercial Bank in lieu of its NFCC computation (Annex 3-B).</p> <p>* Should the bidder opt to submit NFCC, computation must be at least equal to the ABC to be bid, calculated as follows.</p> <p>NFCC = [(Current assets minus current liabilities) (15)] minus the value of all ongoing contracts, including awarded contracts yet to be started.</p>

	<p>* The values of the domestic bidder's current assets and current liabilities shall be based on the latest Annual Income Tax Return and Audited Financial Statements filed thru eFPS.</p> <p>* For foreign bidders, the value of the current assets and current liabilities shall be based on their latest Audited Financial Statements (AFS) prepared in accordance with international reporting standards. The NFCC computation shall be expressed in Philippine Peso based on the prevailing exchange rate as published in the BSP reference rate bulletin on the date of preparation of the AFS.</p> <p>* If the prospective bidder opts to submit a Committed Line of Credit, it must be at least equal to ten percent (10%) of the ABC of the project issued by local universal or commercial bank. The amount of Committed Line of Credit must be Machine Validated.</p>
Class "B" Documents	
E	<p>Duly signed Joint Venture Agreement (JVA) in case the joint venture is already in existence;or</p> <p>In the absence of a JVA, duly Notarized Statement/s from all the potential joint venture partners stating that they will enter into and abide by the provisions of the JVA in the instance that the bid is successful. Failure to enter into a joint venture in the event of a contract award shall be ground for the forfeiture of the bid security; or</p> <p>In case JVA is not applicable, the bidder must submit a duly signed Statement stating that JVA is not applicable in lieu of the foregoing(Annex 4).</p> <p>*Note:</p> <ul style="list-style-type: none"> The JVA should be specific to the project including the purpose and all supporting documents related thereto.
F	Bid security in the prescribed form, amount and validity period; or a Notarized Bid Securing Declaration(Annex 5) .
G	Conformity with the Schedule of Requirements (Annex 6-A) .
	Duly signed statement of compliance to Technical Specifications (Annex 6-B) .
	Warranty Undertaking (Annex 6-C) .
	Certificate of Replacement for Defective Items(Annex 6-D) .
	Prototype samples required for testing during post-qualification in conformance with the technical specification and Test and Acceptance Procedure under QM SPEC NR OE-23T36R165 dated 30 May 2017; QM SPEC NR OE-23T425x65 R22.5 dated 09 Aug 2019; and QM SPEC NR OE-23T315x80 R22.5 dated 09 Aug 2019
	*Note: Failure to pay the testing fee within two (2) calendar days from notice (which can be via email, call, or text) shall be tantamount to non-compliance with

	this requirement and shall be a ground for disqualification.
H	<p>Certificate from Armed Forces of the Philippines Procurement Service (AFPPS) that the Bidder is not Blacklisted; or</p> <p>In the absence of the said Certificate, the Bidder shall submit proof of application of the same stamped received by AFPPS if manually filed, or acknowledged received by the AFPPS through its official email address:afppsthree@gmail.com if electronically filed.</p> <p>*Note:</p> <ul style="list-style-type: none"> • In case of Joint Venture, each JV partner shall submit the Certificate.
I	Notarized Omnibus Sworn Statement(Annex 7).
J	<p>Proof of Authority of the designated representative/s for purposes of the bidding</p> <p><u>For Local Bidder:</u></p> <ol style="list-style-type: none"> Duly notarized Special Power of Attorney – For Sole Proprietorship if owner opts to designate a representative/s; OR Duly notarized Secretary’s Certificate evidencing the authority of the designated representative/s, issued by the corporation, cooperative or the members of the joint venture. <p><u>For Foreign Bidder:</u></p> <ol style="list-style-type: none"> Valid and Current Written Appointment of the Philippine based company (as local representative of foreign manufacturer) issued by the foreign bidder. The written appointment must include detailed scope of responsibility of the local representative. A Certified True Copy of the Written Appointment may be submitted subject to the presentation of the original document during post qualification; AND Duly Notarized authorization of the duly registered Philippine-based company representative(e.g. Secretary’s Certificate for Corporation, Special Power of Attorney for Sole Proprietor) with specimen signature of the authorized representative to transact with PA/AFP including address, telephone number, fax number and email address; <p>OR</p> <ol style="list-style-type: none"> <i>In case the authorized local representative is an individual (citizen of the Philippines), a Valid and Current Written Appointment of the said individual as the local representative issued by the foreign bidder</i> must be submitted. The written appointment must include detailed scope of responsibility of the local representative. A Certified True Copy of the Written Appointment may be submitted subject to the presentation of the original document during post

qualification.

Note 1 (for both local and foreign bidders): Provided that in the case of unincorporated joint venture, each member shall submit their respective Special Power of Attorney and/or Secretary's Certificate evidencing the authority of the designated representatives for purposes of this bidding

Note 2 (for both local and foreign bidders): The Secretary's Certificate, Board Resolution or Special Power of Attorney, or its equivalent document/proof of authority of the designated representative/s for purposes of the bidding, must have a specimen signature of the bidder or its authorized representative; it must indicate in the said document the authority to transact with the Philippine Army/AFP; it must be specific to the project; and it must indicate in the same document the address, telephone number, mobile phone number, and email address of the bidder or its authorized representative.

Note 3 (for both local and foreign bidders): In case of Joint Venture, bidder must submit an Original Special Power of Attorney wherein all members of the Joint Venture are signatories, giving full power and authority to the designated representative of the Joint Venture to sign the OSS and to do acts to represent the bidder.

II. FINANCIAL COMPONENT ENVELOPE	
TAB	<i>Financial Documents</i>
A	Bid Form for the Procurement of Goods(Annex 8-A)
	Duly signed and accomplished Financial Bid Form (Annex 8-B)
B	Duly signed and accomplished Price Schedule(s) (Annex 9)

Bidding Forms

Bidding Forms	Annex Nr
Statement of All On-going Government and Private Contracts including Contracts Awarded but not yet started, if any.	Annex 1
Statement of Single Largest Similar Completed Contract within the last five (5) years from date of submission and receipt of bids equivalent to at least twenty-five (25%) of the ABC	Annex 2
Certificate of Net Financial Contracting Capacity (NFCC)	Annex 3-A
Sample Form for Committed Line of Credit	Annex 3-B
Statement that JVA is not applicable	Annex 4
Bid Securing Declaration	Annex 5
Conformity with the Schedule of Requirements	Annex 6-A
Duly signed statement of compliance to Technical Specifications and Test and Evaluation Procedures	Annex 6-B
Warranty Undertaking	Annex 6-C
Certificate of Replacement for Defective Items	Annex 6-D
Omnibus Sworn Statement	Annex 7
Bid Form for the Procurement of Goods	Annex 8-A
Duly signed and Accomplished Financial Bid Form	Annex 8-B
Bid Prices and applicable Price Schedules	Annex 9

Annex 1

(COMPANY LETTERHEAD)

Procurement of Various Tires
Bid Ref. No. QM PABAC1 001-25
Approved Budget Contract: PhP182,638,904.00

Statement of All On-going Government and Private Contracts including Contracts Awarded but not yet started, if any. In case the supplier has no on-going government or private contract, indicate none on the space provided.

1. All On-going Government Contracts

Name of Contract	Date of Contract	Kinds of Goods	Value of Contract	Status of Contract	Date of Delivery	Purchase Order, Notice to Proceed or Contract	Value of Outstanding Contract
TOTAL							

Total Value of Contract: _____

Name of Contract	Date of Contract	Kinds of Goods	Value of Contract	Status of Contract	Date of Delivery	Purchase Order, Notice to Proceed or Contract	Value of Outstanding Contract
TOTAL							

2. All On-going Private Contracts

Total Value of Contract: _____

CERTIFIED CORRECT:

Name & Signature of Authorized Representative

Position

Date

Annex 2

(Company Letterhead)

Procurement of Various Tires
Bid Ref. No. QM PABAC1 001-25
Approved Budget Contract: PhP182,638,904.00

Statement of Single Largest Similar Completed Contract within the last five (5) years from date of submission and receipt of bids equivalent to at least twenty-five (25%) of the ABC

Name of Contract	Date of Contract	Kinds of Goods	Value of Contract	Date of Delivery	End-User's Acceptance or Official Receipts

CERTIFIED CORRECT:

Name & Signature of Authorized Representative

Position

Date

Annex 3-A

CERTIFICATE OF NET FINANCIAL CONTRACTING CAPACITY*(Please show figures at how you arrived at the NFCC)*

This is to certify that our **Net Financial Contracting Capacity (NFCC)** is **Philippine Pesos** _____ (P _____) which is at least equal to the total ceiling price we are bidding.

The amount is computed as follows: $NFCC = (CA - CL) (K) - C$

Where:

CA = Current Assets

CL = Current Liabilities

K = 15

C = value of all outstanding or uncompleted portions of the projects under ongoing contracts, including awarded contracts yet to be started coinciding with the contract for this Project

Issued this _____ day of _____, 2025.

CERTIFIED CORRECT:

Name & Signature of Authorized Representative

Position

Date

Annex 3-B

(Name of Bank)
COMMITTED LINE OF CREDIT

Date: _____

ARMED FORCES OF THE PHILIPPINES
OFFICE OF THE PHILIPPINE ARMY BIDS AND AWARDS COMMITTEE
Fort Andres Bonifacio, Metro Manila

PROJECT : _____
 COMPANY/FIRM : _____
 ADDRESS : _____
 BANK/FINANCING INSTITUTION : _____
 ADDRESS : _____
 AMOUNT : _____

This is to certify that the above Bank/Financing Institution with business address indicated above, commits to provide the (Supplier/Distributor/Manufacturer), if awarded the above-mentioned Contract, a credit line in the amount specified above which shall be exclusively used to finance the performance of the above-mentioned contract subject to our terms, conditions and requirements.

The credit line shall be available on the date of the submission and opening of bids and such line of credit shall be maintained until the project is completed by the Contractor.

This certification is being issued in favor of said (Supplier/Distributor/Manufacturer) in connection with the bidding requirement of (Name of Procuring Entity) for the above-mentioned Contract. We are aware that any false statements issued by us make us liable for perjury.

The committed line of credit cannot be terminated or cancelled without the prior written approval of the OFFICE OF THE PHILIPPINE ARMY BIDS AND AWARDS COMMITTEE.

Name and Signature of Authorized Financing Institution Office

Official Designation

Concurred By:

Name & Signature of (Supplier/Distributor/Manufacturer's) Authorized Representative

Official Designation

SUBSCRIBED AND SWORN TO BEFORE ME this _____ day of _____ at _____, Philippines. Affiant exhibited to me his/her competent Evidence of identity as defined by the 2004 Rules on Notarial Practice (A.M. No. 02-8-13-SC), issued on _____ at _____.

NOTARY PUBLIC

Doc No: _____
Page No: _____
Book No: _____
Series of: _____

Annex 4

(Company Letterhead)

Procurement of Various Tires
Bid Ref. No. QM PABAC1 001-25
Approved Budget Contract: PhP182,638,904.00

This is to certify that _____ (name of bidder) _____ will be participating **without a joint venture partner** in the procurement of _____ (name of project) _____.

Further, the undersigned acknowledges that **Joint Venture Agreement is Not Applicable** for the above-mentioned project.

CERTIFIED CORRECT:

Name & Signature of Authorized Representative

Position

Date

Annex 5

Name of Project: _____
 Public Bidding Nr: _____
 ABC: _____

BID-SECURING DECLARATION

REPUBLIC OF THE PHILIPPINES)
 CITY OF

BID-SECURING DECLARATION

Invitation to Bid/Request for Expression of Interest No. 1: (Insert reference number)

To: (Insert name and address of the Procuring Entity)

I/We, the undersigned, declare that:

1. I/We understand that, according to your conditions, bids must be supported by a Bid Security, which may be in the form of a Bid-Securing Declaration.
2. I/We accept that: (a) I/We will be automatically disqualified from bidding for any contract with any procuring entity for a period of two (2) years upon receipt of your Blacklisting Order; and (b) I/We will pay the applicable fine provided under Section 6 of the Guidelines on the Use of Bid Securing Declarations, within fifteen (15) days from receipt of the written demand by the procuring entity for the commission of acts resulting to the enforcement of the bid securing declaration under Sections 23.1 (b), 34.2, 40.1 and 69.1, except 69.1 (f) of the IRR of RA 9184; without prejudice to other legal action the government may undertake.
3. I/We understand that this Bid-Securing Declaration shall cease to be valid on the following circumstances:
 - a) Upon expiration of the bid validity period, or any extension thereof pursuant to your request;
 - b) I am/we are declared ineligible or post-disqualified upon receipt of your notice to such effect, and (i) I/We failed to timely file a request for consideration or (ii) I/We filed a waiver to avail of said right;
 - c) I am/were declared as the bidder with the Lowest Calculated and Responsive Bid/Highest Rated and Responsive Bids, and I/We have furnished the performance security and signed the Contract.

IN WITNESS WHEREOF, I/We hereunto set my/our hand/s this _____ day of
 (Month) (Year) at (Place of Execution).

NAME OF BIDDERS AUTHORIZED REPRESENTATIVE

(Insert signatory's legal capacity)

AFFIANT

SUBSCRIBED AND SWORN TO BEFORE ME this _____ day of _____ at _____, Philippines. Affiant exhibited to me his/her competent Evidence of identity as defined by the 2004 Rules on Notarial Practice (A.M. No. 02-8-13-SC), issued on _____ at _____.

NOTARY PUBLIC

Doc No: _____
Page No: _____
Book No: _____
Series of: _____

Annex 6-A

SCHEDULE OF REQUIREMENTS

Procurement of Various Tires
Bid Ref. No. QM PABAC1 001-25
Approved Budget Contract: PhP182,638,904.00

TO THE BIDDER: Indicate "COMPLY" If proposal meets the technical specifications and project requirements. DO NOT LEAVE ANY BLANK. A "YES OR NO" ENTRY WILL NOT BE ACCEPTED. FAILURE TO CONFORM WILL RESULT IN A RATING OF "FAILED".				
Description	Qty/Unit	Full Delivery within;	Delivery Place	Bidders Proposal
Tire, 425x65 R22.5	80 each	Full Delivery within two hundred fifty (250) Calendar Days upon Receipt of NTP	GS Warehouse, 1LSG, Army Support Command, PA, Camp General Servillano Aquino, San Miguel, Tarlac City	
Tire, 315x80 R22.5	100 each			
	5,563 each			
Tire, 36x12.5 R16.5 LT	3,100 each		10FSSU, 2LSG, ASCOM, PA, Camp Evangelista, Patag, Cagayan de Oro City	

CERTIFIED CORRECT:

Name & Signature of Authorized Representative

Position

Date

Annex 6-B

COMPLIANCE TO TECHNICAL SPECIFICATION

Procurement of Various Tires
Bid Ref. No. QM PABAC1 001-25
Approved Budget Contract: PhP182,638,904.00

TO THE BIDDER: Indicate “COMPLY” If proposal meets the technical specifications and project requirements. **DO NOT LEAVE ANY BLANK. A “YES OR NO” ENTRY WILL NOT BE ACCEPTED. FAILURE TO CONFORM WILL RESULT IN A RATING OF “FAILED”.**

Quantity/Item Description	Required Technical Specifications/Test Parameters	Bidder's Proposal
Tire, 425x65 R22.5	QM SPEC NR OE-23T425X65 R22.5 date 09 Aug 2019	
Tire, 315x80 R22.5	QM SPEC NR OE-23T315X80 R22.5 date 09 Aug 2019	
Tire, 36x12.5 R16.5 LT	QM SPEC NR OE-23T36R165 date 30 May 2017	

I/WE, the undersigned bidder, have examined the Bidding Documents including Bid Bulletins, as applicable, hereby OFFER to (supply/deliver/perform) the above-described items.

I/WE undertake, if our bid is accepted, to deliver the items in accordance with the terms and conditions contained in the bid documents, including the posting of the required performance security **within ten (10) calendar days** from receipt of the Notice of Award.

Until a formal contract/order confirmation is prepared and signed, this Bid is binding on us.

Name of Company

Signature of Company Representative

Name & Designation

Date

Annex 6-C

(Bidder's Company Letterhead)

WARRANTY UNDERTAKING**Procurement of Various Tires
Bid Ref. No. QM PABAC1 001-25
Approved Budget Contract: PhP182,638,904.00**

I/We, _____ (Name) _____, _____ (Title/Capacity) _____, the duly authorized representative of _____ (Company/Bidder) _____, hereby commits that should we be awarded the contract, we will issue a Warranty Certificate in favor of the Philippine Army (PA) valid for **six (6) months** from date of final acceptance.

This Undertaking shall form part of the Technical Requirements for the aforesaid procurement project

Signature of Company Representative

Name & Designation

Date

Annex 6-D

(Bidder's Company Letterhead)

**CERTIFICATE OF REPLACEMENT FOR DEFECTIVE
ITEMS****Procurement of Various Tires
Bid Ref. No. QM PABAC1 001-25
Approved Budget Contract: PhP182,638,904.00**

I/We, _____ (Name) _____, _____ (Title/Capacity) _____, the duly authorized representative of (Company/Bidder) _____, hereby commits that should we be awarded the contract, we will replace all defective items **within thirty (30) calendar days** upon receipt of Notice of Defects from the Philippine Army.

Supplier further certifies that the goods to be delivered have been manufactured **not more than one (1) year** from the date of delivery.

This Certification shall form part of the Technical Requirements for the aforesaid procurement project.

Issued this _____ day of _____ 2025 in _____, Philippines

Name of Company (Bidder)

Full Name of Authorized Representative

Address

Signature of Authorized Representative

Tel. No./Fax

E-mail Address

Annex 7

Omnibus Sworn Statement (Revised)
[shall be submitted with the Bid]

REPUBLIC OF THE PHILIPPINES)
 CITY/MUNICIPALITY OF _____) S.S.

AFFIDAVIT

I, [Name of Affiant], of legal age, [Civil Status], [Nationality], and residing at [Address of Affiant], after having been duly sworn in accordance with law, do hereby depose and state that:

1. *[Select one, delete the other:]*

[If a sole proprietorship:] I am the sole proprietor or authorized representative of [Name of Bidder] with office address at [address of Bidder];

[If a partnership, corporation, cooperative, or joint venture:] I am the duly authorized and designated representative of [Name of Bidder] with office address at [address of Bidder];

2. *[Select one, delete the other:]*

[If a sole proprietorship:] As the owner and sole proprietor, or authorized representative of [Name of Bidder], I have full power and authority to do, execute and perform any and all acts necessary to participate, submit the bid, and to sign and execute the ensuing contract for [Name of the Project] of the [Name of the Procuring Entity], as shown in the attached duly notarized Special Power of Attorney;

[If a partnership, corporation, cooperative, or joint venture:] I am granted full power and authority to do, execute and perform any and all acts necessary to participate, submit the bid, and to sign and execute the ensuing contract for [Name of the Project] of the [Name of the Procuring Entity], as shown in the attached [state title of attached document showing proof of authorization (e.g., duly notarized Secretary's Certificate, Board/Partnership Resolution, or Special Power of Attorney, whichever is applicable)];

3. [Name of Bidder] is not "blacklisted" or barred from bidding by the Government of the Philippines or any of its agencies, offices, corporations, or Local Government Units, foreign government/foreign or international financing institution whose blacklisting rules have been recognized by the Government Procurement Policy Board, **by itself or by relation, membership, association, affiliation, or controlling interest with another blacklisted person or entity as defined and provided for in the Uniform Guidelines on Blacklisting;**

4. Each of the documents submitted in satisfaction of the bidding requirements is an authentic copy of the original, complete, and all statements and information provided

therein are true and correct;

5. [Name of Bidder] is authorizing the Head of the Procuring Entity or its duly authorized representative(s) to verify all the documents submitted;
6. *[Select one, delete the rest:]*

[If a sole proprietorship:] The owner or sole proprietor is not related to the Head of the Procuring Entity, members of the Bids and Awards Committee (BAC), the Technical Working Group, and the BAC Secretariat, the head of the Project Management Office or the end-user unit, and the project consultants by consanguinity or affinity up to the third civil degree;

[If a partnership or cooperative:] None of the officers and members of *[Name of Bidder]* is related to the Head of the Procuring Entity, members of the Bids and Awards Committee (BAC), the Technical Working Group, and the BAC Secretariat, the head of the Project Management Office or the end-user unit, and the project consultants by consanguinity or affinity up to the third civil degree;

[If a corporation or joint venture:] None of the officers, directors, and controlling stockholders of *[Name of Bidder]* is related to the Head of the Procuring Entity, members of the Bids and Awards Committee (BAC), the Technical Working Group, and the BAC Secretariat, the head of the Project Management Office or the end-user unit, and the project consultants by consanguinity or affinity up to the third civil degree;

7. *[Name of Bidder]* complies with existing labor laws and standards; and
8. *[Name of Bidder]* is aware of and has undertaken the responsibilities as a Bidder in compliance with the Philippine Bidding Documents, which includes:
 - a. Carefully examining all of the Bidding Documents;
 - b. Acknowledging all conditions, local or otherwise, affecting the implementation of the Contract;
 - c. Making an estimate of the facilities available and needed for the contract to be bid, if any; and
 - d. Inquiring or securing Supplemental/Bid Bulletin(s) issued for the *[Name of the Project]*.
9. *[Name of Bidder]* did not give or pay directly or indirectly, any commission, amount, fee, or any form of consideration, pecuniary or otherwise, to any person or official, personnel or representative of the government in relation to any procurement project or activity.

10. **In case advance payment was made or given, failure to perform or deliver any of the obligations and undertakings in the contract shall be sufficient grounds to constitute criminal liability for Swindling (Estafa) or the commission of fraud with unfaithfulness or abuse of confidence through misappropriating or converting any payment received by a person or entity under an obligation involving the duty to deliver certain goods or services, to the prejudice of the public and the government of the Philippines pursuant to Article 315 of Act No. 3815 s. 1930, as amended, or the Revised Penal Code.**

IN WITNESS WHEREOF, I have hereunto set my hand this ___ day of ___, 20___
at _____, Philippines.

Bidder's Representative/Authorized Signatory
[Insert signatory's legal capacity]
Affiant

[Jurat]

[Format shall be based on the latest Rules on Notarial Practice]

SUBSCRIBED AND SWORN TO BEFORE ME this _____ day of
_____ at _____, Philippines. Affiant exhibited to me his/her competent Evidence of
identity as defined by the 2004 Rules on Notarial Practice (A.M. No. 02-8-13-SC), issued on
_____ at _____.

NOTARY PUBLIC

Doc No: _____
Page No: _____
Book No: _____
Series of: _____

Annex 8-A

Bid Form for the Procurement of Goods
[shall be submitted with the Bid]

BID FORM

Date: _____

Project Identification No.: _____

To: *[name and address of Procuring Entity]*

Having examined the Philippine Bidding Documents (PBDs) including the Supplemental or Bid Bulletin Numbers *[insert numbers]*, the receipt of which is hereby duly acknowledged, we, the undersigned, offer to *[supply/deliver/perform]* *[description of the Goods]* in conformity with the said PBDs for the sum of *[total Bid amount in words and figures]* or the total calculated bid price, as evaluated and corrected for computational errors, and other bid modifications in accordance with the Price Schedules attached herewith and made part of this Bid. The total bid price includes the cost of all taxes, such as, but not limited to: *[specify the applicable taxes, e.g. (i) value added tax (VAT), (ii) income tax, (iii) local taxes, and (iv) other fiscal levies and duties]*, which are itemized herein or in the Price Schedules, If our Bid is accepted, we undertake:

- a. to deliver the goods in accordance with the delivery schedule specified in the Schedule of Requirements of the Philippine Bidding Documents (PBDs);
- b. to provide a performance security in the form, amounts, and within the times prescribed in the PBDs;
- c. to abide by the Bid Validity Period specified in the PBDs and it shall remain binding upon us at any time before the expiration of that period.

[Insert this paragraph if Foreign-Assisted Project with the Development Partner:

Commissions or gratuities, if any, paid or to be paid by us to agents relating to this Bid, and to contract execution if we are awarded the contract, are listed below:

Name and address of agent	Amount	Purpose
Currency	Commission or gratuity	

(if none, state "None")]

Until a formal Contract is prepared and executed, this Bid, together with your written acceptance thereof and your Notice of Award, shall be binding upon us.

We understand that you are not bound to accept the Lowest Calculated Bid or any Bid you may receive.

We certify/confirm that we comply with the eligibility requirements pursuant to the PBDs.

The undersigned is authorized to submit the bid on behalf of *[name of the bidder]* as evidenced by the attached *[state the written authority]*.

We acknowledge that failure to sign each and every page of this Bid Form, including the attached Schedule of Prices, shall be a ground for the rejection of our bid.

Name: _____ Legal capacity: _____ Signature: _____
Duly authorized to sign the Bid for and behalf of: _____ Date: _____

Annex 8-B

(Bidder's Company Letterhead)

Procurement of Various Tires
Bid Ref. No. QM PABAC1 001-25
Approved Budget Contract: PhP182,638,904.00

FINANCIAL BID FORM

Description	Qty	ABC Price		Bidder's Proposal	
		U/P	Total Price	U/P	Total Price
Tire, 425x65 R22.5	80 each	78,400.00	6,272,000.00		
Tire, 315x80 R22.5	100 each	99,680.00	9,968,000.00		
Tire, 36x12.5 R16.5 LT	8,663 each	19,208.00	166,398,904.00		

TOTAL BID PRICE**Total Bid Price (Amount in Words):****BIDDER'S UNDERTAKING**

I/We, the undersigned bidder, having examined the Bidding Documents including Bid Bulletins, as applicable, hereby OFFER to (supply/deliver/perform) the above-described items.

I/We undertake, if our bid is accepted, to deliver the items in accordance with the terms and conditions contained in the bid documents, including the posting of the required performance security within ten (10) calendar days from receipt of Notice of Award.

Until a formal contract/order confirmation is prepared and signed, this Bid is binding on us.

 Name of Company (in print)

 Signature of Company Representative

 Name & Designation (in print)

 Date

Annex 9
FORM NO. 1

(Bidder's Company Letterhead)

Procurement of Various Tires
Bid Ref. No. QM PABAC1 001-25
Approved Budget Contract: PhP182,638,904.00

For Goods Offered From Abroad

Name of Bidder _____ Invitation to Bid¹ Number ___. Page ____ of _____.

1	2	3	4	5	6	7	8	9
Item	Description	Country of origin	Qty	Unit price CIF port of entry (specify port) or CIP named place (specify border point or place of destination)	Total CIF or CIP price per item (col. 4 x 5)	Unit Price Delivered at Place (DAP)	Unit price Delivered Duty Paid (DDP)	Total Price -(if DAP col 4X7) -(If DDP col 4X8)

Note: If the particular column is not applicable indicate **dash (-)** or **zero (0)**, as applicable.

[signature]

[in the capacity of]

Duly authorized to sign Bid for and

¹ If ADB, JICA and WB funded projects, use IFB.

**Annex 9
FORM NO. 2**

(Bidder's Company Letterhead)

**Procurement of Various Tires
Bid Ref. No. QM PABAC1 001-25
Approved Budget Contract: PhP182,638,904.00**

For Goods Offered From Within the Philippines

Name of Bidder _____ . Invitation to Bid² Number _ . Page _ of ____ .

1	2	3	4	5	6	7	8	9	10
Item	Description	Country of origin	Quantity	Unit price EXW per item	Transportation and Insurance and all other costs incidental to delivery, per item	Sales and other taxes payable if Contract is awarded, per item	Cost of Incidental Services, if applicable, per item	Total Price, per unit (col 5+6+7+8)	Total Price delivered Final Destination (col 9) x (col 4)

Note: If the particular column is not applicable indicate **dash (-)** or **zero (0)**, as applicable.

_____ *[signature]*

_____ *[in the capacity of]*

Duly authorized to sign Bid for and on behalf of _____

² If ADB, JICA and WB funded projects, use IFB.

