



HEADQUARTERS  
ARMED FORCES OF THE PHILIPPINES BIDS AND AWARDS COMMITTEE  
OFFICE OF THE PHILIPPINE ARMY BIDS AND AWARDS COMMITTEE 1  
Fort Andres Bonifacio, Taguig City

# **BIDDING DOCUMENTS**

for the

**Procurement of 29,366 each  
Backpack, Tactical, MOLLE, PHILARPAT**

**QM PABAC1 011-25**

	<b>QTY/UNIT</b>	<b>ABC</b>
<b>OG1, PA</b>	<b>10,000 each</b>	<b>PhP25,000,000.00</b>
<b>OG9, PA</b>	<b>19,366 each</b>	<b>PhP48,415,000.00</b>
<b>TOTAL</b>	<b>29,366 each</b>	<b>PhP73,415,000.00</b>



## Table of Contents

<b>Glossary of Acronyms, Terms, and Abbreviations .....</b>	<b>2</b>
<b>Section I. Invitation to Bid.....</b>	<b>5</b>
<b>Section II. Instructions to Bidders.....</b>	<b>8</b>
1. Scope of Bid .....	8
2. Funding Information.....	8
3. Bidding Requirements .....	8
4. Corrupt, Fraudulent, Collusive, and Coercive Practices .....	8
5. Eligible Bidders.....	8
6. Origin of Goods .....	9
7. Subcontracts .....	9
8. Pre-Bid Conference .....	9
9. Clarification and Amendment of Bidding Documents .....	9
10. Documents comprising the Bid: Eligibility and Technical Components .....	10
11. Documents comprising the Bid: Financial Component .....	10
12. Bid Prices .....	10
13. Bid and Payment Currencies .....	11
14. Bid Security .....	11
15. Sealing and Marking of Bids .....	11
16. Deadline for Submission of Bids .....	12
17. Opening and Preliminary Examination of Bids .....	12
18. Domestic Preference .....	12
19. Detailed Evaluation and Comparison of Bids .....	12
20. Post-Qualification .....	13
21. Signing of the Contract .....	13
<b>Section III. Bid Data Sheet .....</b>	<b>14</b>
<b>Section IV. General Conditions of Contract.....</b>	<b>18</b>
1. Scope of Contract .....	18
2. Advance Payment and Terms of Payment .....	18
3. Performance Security .....	18
4. Inspection and Tests .....	18
5. Warranty .....	19
6. Liability of the Supplier .....	19
<b>Section V. Special Conditions of Contract .....</b>	<b>20</b>
<b>Section VI. Schedule of Requirements .....</b>	<b>26</b>
<b>Section VII. Technical Specifications .....</b>	<b>27</b>
<b>Section VIII. Checklist of Technical and Financial Documents .....</b>	<b>50</b>

## *Glossary of Acronyms, Terms, and Abbreviations*

**ABC** – Approved Budget for the Contract.

**BAC** – Bids and Awards Committee.

**Bid** – A signed offer or proposal to undertake a contract submitted by a bidder in response to and in consonance with the requirements of the bidding documents. Also referred to as *Proposal* and *Tender*. (2016 revised IRR, Section 5[c])

**Bidder** – Refers to a contractor, manufacturer, supplier, distributor and/or consultant who submits a bid in response to the requirements of the Bidding Documents. (2016 revised IRR, Section 5[d])

**Bidding Documents** – The documents issued by the Procuring Entity as the bases for bids, furnishing all information necessary for a prospective bidder to prepare a bid for the Goods, Infrastructure Projects, and/or Consulting Services required by the Procuring Entity. (2016 revised IRR, Section 5[e])

**BIR** – Bureau of Internal Revenue.

**BSP** – Bangko Sentral ng Pilipinas.

**Consulting Services** – Refer to services for Infrastructure Projects and other types of projects or activities of the GOP requiring adequate external technical and professional expertise that are beyond the capability and/or capacity of the GOP to undertake such as, but not limited to: (i) advisory and review services; (ii) pre-investment or feasibility studies; (iii) design; (iv) construction supervision; (v) management and related services; and (vi) other technical services or special studies. (2016 revised IRR, Section 5[i])

**CDA** - Cooperative Development Authority.

**Contract** – Refers to the agreement entered into between the Procuring Entity and the Supplier or Manufacturer or Distributor or Service Provider for procurement of Goods and Services; Contractor for Procurement of Infrastructure Projects; or Consultant or Consulting Firm for Procurement of Consulting Services; as the case may be, as recorded in the Contract Form signed by the parties, including all attachments and appendices thereto and all documents incorporated by reference therein.

**CIF** – Cost Insurance and Freight.

**CIP** – Carriage and Insurance Paid.

**CPI** – Consumer Price Index.

**DDP** – Refers to the quoted price of the Goods, which means “delivered duty paid.”

**DTI** – Department of Trade and Industry.

**EXW** – Ex works.

**FCA** – “Free Carrier” shipping point.

**FOB** – “Free on Board” shipping point.

**Foreign-funded Procurement or Foreign-Assisted Project**–Refers to procurement whose funding source is from a foreign government, foreign or international financing institution as specified in the Treaty or International or Executive Agreement. (2016 revised IRR, Section 5[b]).

**Framework Agreement** – Refers to a written agreement between a procuring entity and a supplier or service provider that identifies the terms and conditions, under which specific purchases, otherwise known as “Call-Offs,” are made for the duration of the agreement. It is in the nature of an option contract between the procuring entity and the bidder(s) granting the procuring entity the option to either place an order for any of the goods or services identified in the Framework Agreement List or not buy at all, within a minimum period of one (1) year to a maximum period of three (3) years. (GPPB Resolution No. 27-2019)

**GFI** – Government Financial Institution.

**GOCC** –Government-owned and/or –controlled corporation.

**Goods** – Refer to all items, supplies, materials and general support services, except Consulting Services and Infrastructure Projects, which may be needed in the transaction of public businesses or in the pursuit of any government undertaking, project or activity, whether in the nature of equipment, furniture, stationery, materials for construction, or personal property of any kind, including non-personal or contractual services such as the repair and maintenance of equipment and furniture, as well as trucking, hauling, janitorial, security, and related or analogous services, as well as procurement of materials and supplies provided by the Procuring Entity for such services. The term “related” or “analogous services” shall include, but is not limited to, lease or purchase of office space, media advertisements, health maintenance services, and other services essential to the operation of the Procuring Entity. (2016 revised IRR, Section 5[r])

**GOP** – Government of the Philippines.

**GPPB** –Government Procurement Policy Board.

**INCOTERMS** – International Commercial Terms.

**Infrastructure Projects** – Include the construction, improvement, rehabilitation, demolition, repair, restoration or maintenance of roads and bridges, railways, airports, seaports, communication facilities, civil works components of information technology projects, irrigation, flood control and drainage, water supply, sanitation, sewerage and solid waste management systems, shore protection, energy/power and electrification facilities, national

buildings, school buildings, hospital buildings, and other related construction projects of the government. Also referred to as *civil works or works*. (2016 revised IRR, Section 5[u])

**LGUs** – Local Government Units.

**NFCC** – Net Financial Contracting Capacity.

**NGA** – National Government Agency.

**PhilGEPS** - Philippine Government Electronic Procurement System.

**Procurement Project** – refers to a specific or identified procurement covering goods, infrastructure project or consulting services. A Procurement Project shall be described, detailed, and scheduled in the Project Procurement Management Plan prepared by the agency which shall be consolidated in the procuring entity's Annual Procurement Plan. (GPPB Circular No. 06-2019 dated 17 July 2019)

**PSA** – Philippine Statistics Authority.

**SEC** – Securities and Exchange Commission.

**SLCC** – Single Largest Completed Contract.

**Supplier** – refers to a citizen, or any corporate body or commercial company duly organized and registered under the laws where it is established, habitually established in business and engaged in the manufacture or sale of the merchandise or performance of the general services covered by his bid. (Item 3.8 of GPPB Resolution No. 13-2019, dated 23 May 2019). Supplier as used in these Bidding Documents may likewise refer to a distributor, manufacturer, contractor, or consultant.

**UN** – United Nations.

## ***Section I. Invitation to Bid***

HEADQUARTERS  
ARMED FORCES OF THE PHILIPPINES BIDS AND AWARDS COMMITTEE  
**OFFICE OF THE PHILIPPINE ARMY BIDS AND AWARDS COMMITTEE 1**  
Fort Andres Bonifacio, Taguig City

### **INVITATION TO BID FOR THE PROCUREMENT OF 29,366 EACH BACKPACK, TACTICAL, MOLLE, PHILARPAT**

1. The Philippine Army, through the Philippine Army Appropriation CY 2025 with OG10 Certification dated 02 August 2024 valid until 31 December 2025 for OG1, PA and National Expenditure Program (NEP) for OG9, respectively, intends to apply the sum of **Seventy-Three Million Four Hundred Fifteen Thousand Pesos (PhP73,415,000.00)** being the ABC to payments under the contract for the Procurement of **29,366 each Backpack, Tactical, MOLLE, PHILARPAT under QM PABAC1 011-25**. Bids received in excess of the ABC shall be automatically rejected at bid opening.
2. The Philippine Army now invites bids for the above Procurement Project. Delivery of the Goods is required **One Hundred Eighty (180) calendar days** from the receipt of Notice to Proceed (NTP) by the supplier, which date shall not be later than seven (7) days from the issuance of NTP. Bidders should have completed, within five (5) years from the date of submission and receipt of bids, a contract similar to the Project. The description of an eligible bidder is contained in the Bidding Documents, particularly, in Section II (Instructions to Bidders).
3. Bidding will be conducted through open competitive bidding procedures using a non-discretionary “*pass/fail*” criterion as specified in the 2016 revised Implementing Rules and Regulations (IRR) of Republic Act (RA) No. 9184.

Bidding is open to all interested bidders, whether local or foreign, subject to the conditions for eligibility provided in the 2016 revised IRR of RA No. 9184.

4. Prospective Bidders may obtain further information from the Philippine Army and inspect the Bidding Documents at the address given below office hours (8:00AM to 4:00PM) on weekdays only.
5. A complete set of Bidding Documents may be acquired by interested Bidders on \_\_\_\_\_ from the given address and website(s) below and upon payment of the applicable fee for the Bidding Documents, pursuant to the latest Guidelines issued by the GPPB in the amount of Twenty Five Thousand Pesos (PhP25,000.00). The Procuring Entity shall allow the bidder to present its proof of payment for the fees in person, by facsimile, or through electronic means.
6. The Philippine Army through PABAC1 will hold a Pre-Bid Conference on the time and date as specified below at the Office of the PABAC1, Fort Andres Bonifacio, Taguig, and/or through video conferencing or webcasting via Zoom, which shall be open to prospective bidders.

7. Bids must be duly received by the BAC Secretariat through manual submission at the office address indicated below, on or before the date of submission. Late bids shall not be accepted.
8. All Bids must be accompanied by a bid security in any of the acceptable forms and in the amount stated in **ITB** Clause 14.
9. Bid opening shall be on the date as specified below and at the given address below and/or through video conferencing or webcasting. Bids will be opened in the presence of the bidders' representatives who choose to attend the activity.

The schedule of the bidding activities shall be as follows:

ACTIVITIES	TIME and DATE	VENUE
1. Sale and Issuance of Bidding Documents	8:00AM to 4:00 P.M Mondays to Fridays only starting on September 27 to October 17, 2024	PABAC1 Secretariat/ Conference Room, PABAC Building, Fort Andres Bonifacio, Taguig City
2. Pre-Bid Conference	04 October 2024 at 8:30 A.M. (Fri)	
3. Deadline of Submission of Bids	On or before 17 October 2024 at 8:30 A.M. (Thu)	
4. Opening of Bids and Evaluation	17 October 2024 at 8:30 A.M. (Thu) onwards	

10. The Philippine Army reserves the right to reject any and all bids, declare a failure of bidding, or not award the contract at any time prior to contract award in accordance with Sections 35.6 and 41 of the 2016 revised IRR of RA No. 9184, without thereby incurring any liability to the affected bidder or bidders.

Tie breaking method shall be non-discretionary and non-discriminatory. The same shall be based on sheer luck or chance (Toss Coin) and in chronological order based on the submission of bids.

11. For further information, please refer to:

**Office of the PA Bids and Awards Committee 1**  
Fort Andres Bonifacio, Taguig City

**MGEN LEONEL M NICOLAS PA**  
*PABAC1 Chairperson*  
Contact Nr. +63999-321-1164/+63977-488-0012  
Telephone Nr. 845-9555 local 6891  
Email address: pabacsec@gmail.com

12. You may visit the following websites:

For downloading of Bidding Documents:

- [philgeps.gov.ph](http://philgeps.gov.ph)
- [army.mil.ph](http://army.mil.ph)



Date of issue: \_\_\_\_\_



**MGEN LEONEL M NICOLAS**  
*PABAC1 Chairperson*

## ***Section II. Instructions to Bidders***

### **1. Scope of Bid**

The Procuring Entity, Philippine Army wishes to receive Bids for the **Procurement of 29,366 each Backpack, Tactical, MOLLE, PHILARPAT under QM PABAC1 011-25.**

The Procurement Project (referred to herein as “Project”) is composed of **one lot**, the details of which are described in Section VII (Technical Specifications).

### **2. Funding Information**

2.1. The GOP through the source of funding as indicated below for 2025 in the amount of **Seventy-Three Million Four Hundred Fifteen Thousand Pesos (PhP73,415,000.00).**

2.2. The source of funding is: NGA, National Expenditure Program FY 2025.

### **3. Bidding Requirements**

The Bidding for the Project shall be governed by all the provisions of RA No. 9184 and its 2016 revised IRR, including its Generic Procurement Manuals and associated policies, rules and regulations as the primary source thereof, while the herein clauses shall serve as the secondary source thereof.

Any amendments made to the IRR and other GPPB issuances shall be applicable only to the ongoing posting, advertisement, or **IB** by the BAC through the issuance of a supplemental or bid bulletin.

The Bidder, by the act of submitting its Bid, shall be deemed to have verified and accepted the general requirements of this Project, including other factors that may affect the cost, duration and execution or implementation of the contract, project, or work and examine all instructions, forms, terms, and project requirements in the Bidding Documents.

### **4. Corrupt, Fraudulent, Collusive, and Coercive Practices**

The Procuring Entity, as well as the Bidders and Suppliers, shall observe the highest standard of ethics during the procurement and execution of the contract. They or through an agent shall not engage in corrupt, fraudulent, collusive, coercive, and obstructive practices defined under Annex “I” of the 2016 revised IRR of RA No. 9184 or other integrity violations in competing for the Project.

### **5. Eligible Bidders**

5.1. Only Bids of Bidders found to be legally, technically, and financially capable will be evaluated.

- 5.2. Foreign ownership exceeding those allowed under the rules may participate pursuant to:
- i. When a Treaty or International or Executive Agreement as provided in Section 4 of the RA No. 9184 and its 2016 revised IRR allow foreign bidders to participate;
  - ii. Citizens, corporations, or associations of a country, included in the list issued by the GPPB, the laws or regulations of which grant reciprocal rights or privileges to citizens, corporations, or associations of the Philippines;
  - iii. When the Goods sought to be procured are not available from local suppliers; or
  - iv. When there is a need to prevent situations that defeat competition or restrain trade.
- 5.3. Pursuant to Section 23.4.1.3 of the 2016 revised IRR of RA No.9184, the Bidder shall have an SLCC that is at least one (1) contract similar to the Project the value of which, adjusted to current prices using the PSA's CPI, must be at least equivalent to at least twenty-five percent (25%) of the ABC (Expendable Supplies)
- 5.4. The Bidders shall comply with the eligibility criteria under Section 23.4.1 of the 2016 IRR of RA No. 9184.

## 6. Origin of Goods

There is no restriction on the origin of goods other than those prohibited by a decision of the UN Security Council taken under Chapter VII of the Charter of the UN, subject to Domestic Preference requirements under **ITB** Clause 18.

## 7. Subcontracts

7.1. The Procuring Entity has prescribed that: **Subcontracting is not allowed.**

## 8. Pre-Bid Conference

The Procuring Entity will hold a pre-bid conference for this Project on the specified date and time and either at its physical address and/or through videoconferencing/webcasting as indicated in paragraph 6 of the **IB**.

## 9. Clarification and Amendment of Bidding Documents

Prospective bidders may request for clarification on and/or interpretation of any part of the Bidding Documents. Such requests must be in writing and received by the Procuring Entity, either at its given address or through electronic mail indicated in the **IB**, at least ten (10) calendar days before the deadline set for the submission and receipt of Bids.

## 10. Documents comprising the Bid: Eligibility and Technical Components

- 10.1. The first envelope shall contain the eligibility and technical documents of the Bid as specified in **Section VIII (Checklist of Technical and Financial Documents)**.
- 10.2. The Bidder's SLCC as indicated in **ITB** Clause 5.3 should have been completed within five (5) years prior to the deadline for the submission and receipt of bids.
- 10.3. If the eligibility requirements or statements, the bids, and all other documents for submission to the BAC are in foreign language other than English, it must be accompanied by a translation in English, which shall be authenticated by the appropriate Philippine foreign service establishment, post, or the equivalent office having jurisdiction over the foreign bidder's affairs in the Philippines. Similar to the required authentication above, for Contracting Parties to the Apostille Convention, only the translated documents shall be authenticated through an apostille pursuant to GPPB Resolution No. 13-2019 dated 23 May 2019. The English translation shall govern, for purposes of interpretation of the bid.

## 11. Documents comprising the Bid: Financial Component

- 11.1. The second bid envelope shall contain the financial documents for the Bid as specified in **Section VIII (Checklist of Technical and Financial Documents)**.
- 11.2. If the Bidder claims preference as a Domestic Bidder or Domestic Entity, a certification issued by DTI shall be provided by the Bidder in accordance with Section 43.1.3 of the 2016 revised IRR of RA No. 9184.
- 11.3. Any bid exceeding the ABC indicated in paragraph 1 of the **IB** shall not be accepted.
- 11.4. For Foreign-funded Procurement, a ceiling may be applied to bid prices provided the conditions are met under Section 31.2 of the 2016 revised IRR of RA No. 9184.

## 12. Bid Prices

- 12.1. Prices indicated on the Price Schedule shall be entered separately in the following manner:
  - a. For Goods offered from within the Procuring Entity's country:
    - i. The price of the Goods quoted EXW (ex-works, ex-factory, ex-warehouse, ex-showroom, or off-the-shelf, as applicable);

- ii. The cost of all customs duties and sales and other taxes already paid or payable;
  - iii. The cost of transportation, insurance, and other costs incidental to delivery of the Goods to their final destination; and
  - iv. The price of other (incidental) services, if any, listed in e.
- b. For Goods offered from abroad:
- i. Unless otherwise stated in the **BDS**, the price of the Goods shall be quoted delivered duty paid (DDP) with the place of destination in the Philippines as specified in the **BDS**. In quoting the price, the Bidder shall be free to use transportation through carriers registered in any eligible country. Similarly, the Bidder may obtain insurance services from any eligible source country.
  - ii. The price of other (incidental) services, if any, as listed in **Section VII (Technical Specifications)**.

### 13. Bid and Payment Currencies

13.1. For Goods that the Bidder will supply from outside the Philippines, the bid prices may be quoted in the local currency or tradeable currency accepted by the BSP at the discretion of the Bidder. However, for purposes of bid evaluation, Bids denominated in foreign currencies, shall be converted to Philippine currency based on the exchange rate as published in the BSP reference rate bulletin on the day of the bid opening.

13.2. Payment of the contract price shall be made in **Philippine Peso**.

### 14. Bid Security

14.1. The Bidder shall submit a Bid Securing Declaration or any form of Bid Security in the amount indicated in the **BDS**, which shall be not less than the percentage of the ABC in accordance with the schedule in the **BDS**.

14.2. The Bid and bid security shall be valid within one hundred twenty (120) calendar days from the date of the opening of bids. Any Bid not accompanied by an acceptable bid security shall be rejected by the Procuring Entity as non-responsive.

### 15. Sealing and Marking of Bids

Each Bidder shall submit one copy of the first and second components of its Bid.

The Procuring Entity may request additional hard copies and/or electronic copies of the Bid. However, failure of the Bidders to comply with the said request shall not be a ground for disqualification.

If the Procuring Entity allows the submission of bids through online submission or any other electronic means, the Bidder shall submit an electronic copy of its Bid, which must be digitally signed. An electronic copy that cannot be opened or is corrupted shall be considered non-responsive and, thus, automatically disqualified.

## 16. Deadline for Submission of Bids

- 16.1. The Bidders shall submit on the specified date and time and either at its physical address or through online submission as indicated in paragraph 7 of the **IB**.

## 17. Opening and Preliminary Examination of Bids

- 17.1. The BAC shall open the Bids in public at the time, on the date, and at the place specified in paragraph 9 of the **IB**. The Bidders' representatives who are present shall sign a register evidencing their attendance. In case videoconferencing, webcasting or other similar technologies will be used, attendance of participants shall likewise be recorded by the BAC Secretariat.

In case the Bids cannot be opened as scheduled due to justifiable reasons, the rescheduling requirements under Section 29 of the 2016 revised IRR of RA No. 9184 shall prevail.

- 17.2. The preliminary examination of bids shall be governed by Section 30 of the 2016 revised IRR of RA No. 9184.

## 18. Domestic Preference

- 18.1. The Procuring Entity will grant a margin of preference for the purpose of comparison of Bids in accordance with Section 43.1.2 of the 2016 revised IRR of RA No. 9184.

## 19. Detailed Evaluation and Comparison of Bids

- 19.1. The Procuring BAC shall immediately conduct a detailed evaluation of all Bids rated "*passed*," using non-discretionary pass/fail criteria. The BAC shall consider the conditions in the evaluation of Bids under Section 32.2 of the 2016 revised IRR of RA No. 9184.

- 19.2. If the Project allows partial bids, bidders may submit a proposal on any of the lots or items, and evaluation will be undertaken on a per lot or item basis, as the case maybe. In this case, the Bid Security as required by **ITB** Clause 15 shall be submitted for each lot or item separately.

- 19.3. The descriptions of the lots or items shall be indicated in **Section VII (Technical Specifications)**, although the ABCs of these lots or items are indicated in the **BDS** for purposes of the NFCC computation pursuant to Section 23.4.2.6 of the 2016 revised IRR of RA No. 9184. The NFCC must be

sufficient for the total of the ABCs for all the lots or items participated in by the prospective Bidder.

19.4. The Project shall be awarded as follows:

**One Project having several items that shall be awarded as one contract.**

19.5. Except for bidders submitting a committed Line of Credit from a Universal or Commercial Bank in lieu of its NFCC computation, all Bids must include the NFCC computation pursuant to Section 23.4.1.4 of the 2016 revised IRR of RA No. 9184, which must be sufficient for the total of the ABCs for all the lots or items participated in by the prospective Bidder. For bidders submitting the committed Line of Credit, it must be at least equal to ten percent (10%) of the ABCs for all the lots or items participated in by the prospective Bidder.

## 20. Post-Qualification

20.2. Within a non-extendible period of five (5) calendar days from receipt by the Bidder of the notice from the BAC that it submitted the Lowest Calculated Bid, the Bidder shall submit its latest income and business tax returns filed and paid through the BIR Electronic Filing and Payment System (eFPS) and other appropriate licenses and permits required by law and stated in the **BDS**.

## 21. Signing of the Contract

21.1. The documents required in Section 37.2 of the 2016 revised IRR of RA No. 9184 shall form part of the Contract. Additional Contract documents are indicated in the **BDS**.

## *Section III. Bid Data Sheet*

ITB Clause	
5.3	<p>For this purpose, contracts similar to the Project shall be:</p> <ul style="list-style-type: none"> <li>a. Supply and Delivery of “<b>any sewn items</b>”; and</li> <li>b. Completed within five (5) years prior to the deadline for the submission and receipt of bids.</li> </ul>
7.1	No portion of the contract or project shall be sub-contracted.
10	<p>For foreign bidders, the equivalent document/s issued by the appropriate authority in the country of origin of the bidder concerned must be presented. If said document has no appropriate equivalent, a Certificate of Inexistence of Appropriate Foreign Equivalent may be submitted.</p> <p>The local representative of Foreign Bidders shall also submit PhilGEPS Certificate of Registration (Platinum Membership), or a Valid and Current Proof of Authority issued by the foreign bidder (in case the authorized local representative is an individual).</p> <p>In case of a Joint Venture, each JV partner shall submit the required Legal Documents.</p>
12	For the given scope of work in this Contract as awarded, all bid prices are considered fixed prices, and therefore not subject to price escalation during contract implementation, except under extraordinary circumstances and upon prior approval of the GPPB in accordance with Section 61 of R.A. 9184 and its IRR.
12.1	The price of the Goods shall be quoted DDP <b><i>GS Warehouse 1LSG, Army Support Command, PA, Camp General Servillano Aquino, San Miguel, Tarlac City and GS Warehouse, 2LSG, ASCOM, Camp General Arturo Enrile, Malagutay, Zamboanga City</i></b> the applicable International Commercial Terms (INCOTERMS) for this Project.
14.1	<p>The bid security shall be in the form of a Bid Securing Declaration, or any of the following forms and amounts:</p> <ul style="list-style-type: none"> <li>a. The amount of not less than <b>PhP1,468,300.00 [two percent (2%)</b> of the ABC], if bid security is in cash, cashier’s/manager’s check, bank draft/guarantee or irrevocable letter of credit; or</li> <li>b. The amount of not less than <b>PhP3,670,750.00 [five percent (5%)</b> of the ABC], if bid security is in Surety Bond.</li> </ul> <p>Note: The bid security shall be payable to the Procuring Entity, however, if it is in the form of a manager’s check, it shall be payable to the Collecting Officer, Finance Center, PA.</p>



15	Each Bidder shall submit <b>one (1) original and two (2) photocopies</b> of the first and second components of its bid with proper tabbing.  Note: <ul style="list-style-type: none"> <li>Unsealed and unsigned Bid Envelope and failure to submit the required original copy shall be grounds for disqualification</li> </ul>																			
18	Certification from the DTI if the Bidder claims preference as a Domestic Bidder or Domestic Entity.																			
19.3	The Project shall be awarded as one contract. <table border="1" data-bbox="316 622 1377 891"> <thead> <tr> <th>Description</th> <th>Qty</th> <th>U/P (PhP)</th> <th>ABC (PhP)</th> <th>END USER</th> </tr> </thead> <tbody> <tr> <td rowspan="2">Backpack, Tactical, MOLLE, PHILARPAT</td> <td>10,000 ea</td> <td>2,500.00</td> <td>PhP25,000,000.00</td> <td>OG1, PA/PAMU</td> </tr> <tr> <td>19,366 ea</td> <td>2,500.00</td> <td>PhP48,415,000.00</td> <td>OG9, PA/PAMU</td> </tr> <tr> <td><b>TOTAL</b></td> <td><b>29,366 ea</b></td> <td><b>2,500.00</b></td> <td><b>PhP73,415,000.00</b></td> <td><b>PAWIDE Units</b></td> </tr> </tbody> </table>	Description	Qty	U/P (PhP)	ABC (PhP)	END USER	Backpack, Tactical, MOLLE, PHILARPAT	10,000 ea	2,500.00	PhP25,000,000.00	OG1, PA/PAMU	19,366 ea	2,500.00	PhP48,415,000.00	OG9, PA/PAMU	<b>TOTAL</b>	<b>29,366 ea</b>	<b>2,500.00</b>	<b>PhP73,415,000.00</b>	<b>PAWIDE Units</b>
Description	Qty	U/P (PhP)	ABC (PhP)	END USER																
Backpack, Tactical, MOLLE, PHILARPAT	10,000 ea	2,500.00	PhP25,000,000.00	OG1, PA/PAMU																
	19,366 ea	2,500.00	PhP48,415,000.00	OG9, PA/PAMU																
<b>TOTAL</b>	<b>29,366 ea</b>	<b>2,500.00</b>	<b>PhP73,415,000.00</b>	<b>PAWIDE Units</b>																
20.2	Post-Qualification Requirements: <table border="1" data-bbox="316 965 1377 2031"> <thead> <tr> <th>TAB</th> <th>Additional Post Qualification Requirements</th> <th>Legal Basis</th> </tr> </thead> <tbody> <tr> <td>A</td> <td>Registration Certificate from Securities and Exchange Commission (SEC) for corporations, Department of Trade and Industry (DTI) for sole proprietorship, or Cooperative Development Authority (CDA) for cooperatives or its equivalent document</td> <td>2016 Revised IRR of RA No 9184</td> </tr> <tr> <td>B</td> <td>Current and valid Mayor's Permit or Business Permit issued by the local government where the principal place of business of the bidder is located</td> <td>2016 Revised IRR of RA No 9184</td> </tr> <tr> <td>C</td> <td>Tax Clearance Certificate per Executive Order 398, Series of 2005</td> <td>2016 Revised IRR of RA No 9184</td> </tr> <tr> <td>D</td> <td>Latest Income and Business Tax Returns filed and paid through the BIR Electronic Filing and Payment System (eFPS). The latest income and business tax returns are those within the last six (6) months preceding the date of bid submission.</td> <td>2016 Revised IRR of RA No 9184</td> </tr> <tr> <td>E</td> <td>Latest Audited Financial Statement showing, among others, the prospective bidder's total and current assets and liabilities stamped "<b>received</b>" if manually filed or "<b>attachment of system generated Transaction Reference Number and email to the system user</b>" if electronically filed issued by the Bureau of Internal Revenue or its duly accredited and authorized institutions, for the preceding calendar year which should not be earlier than two (2) years from the date of bid</td> <td>2016 Revised IRR of RA No 9184</td> </tr> </tbody> </table>	TAB	Additional Post Qualification Requirements	Legal Basis	A	Registration Certificate from Securities and Exchange Commission (SEC) for corporations, Department of Trade and Industry (DTI) for sole proprietorship, or Cooperative Development Authority (CDA) for cooperatives or its equivalent document	2016 Revised IRR of RA No 9184	B	Current and valid Mayor's Permit or Business Permit issued by the local government where the principal place of business of the bidder is located	2016 Revised IRR of RA No 9184	C	Tax Clearance Certificate per Executive Order 398, Series of 2005	2016 Revised IRR of RA No 9184	D	Latest Income and Business Tax Returns filed and paid through the BIR Electronic Filing and Payment System (eFPS). The latest income and business tax returns are those within the last six (6) months preceding the date of bid submission.	2016 Revised IRR of RA No 9184	E	Latest Audited Financial Statement showing, among others, the prospective bidder's total and current assets and liabilities stamped " <b>received</b> " if manually filed or " <b>attachment of system generated Transaction Reference Number and email to the system user</b> " if electronically filed issued by the Bureau of Internal Revenue or its duly accredited and authorized institutions, for the preceding calendar year which should not be earlier than two (2) years from the date of bid	2016 Revised IRR of RA No 9184	
TAB	Additional Post Qualification Requirements	Legal Basis																		
A	Registration Certificate from Securities and Exchange Commission (SEC) for corporations, Department of Trade and Industry (DTI) for sole proprietorship, or Cooperative Development Authority (CDA) for cooperatives or its equivalent document	2016 Revised IRR of RA No 9184																		
B	Current and valid Mayor's Permit or Business Permit issued by the local government where the principal place of business of the bidder is located	2016 Revised IRR of RA No 9184																		
C	Tax Clearance Certificate per Executive Order 398, Series of 2005	2016 Revised IRR of RA No 9184																		
D	Latest Income and Business Tax Returns filed and paid through the BIR Electronic Filing and Payment System (eFPS). The latest income and business tax returns are those within the last six (6) months preceding the date of bid submission.	2016 Revised IRR of RA No 9184																		
E	Latest Audited Financial Statement showing, among others, the prospective bidder's total and current assets and liabilities stamped " <b>received</b> " if manually filed or " <b>attachment of system generated Transaction Reference Number and email to the system user</b> " if electronically filed issued by the Bureau of Internal Revenue or its duly accredited and authorized institutions, for the preceding calendar year which should not be earlier than two (2) years from the date of bid	2016 Revised IRR of RA No 9184																		

	submission.	
F	Submitted Prototype samples and swatch materials for testing during SOBE will be the final sample	List of Required prototype samples and swatch materials for testing for Backpack, Tactical, MOLLE, PHILARPAT under QM SPEC NR IE-22BTM with amend 1 dated 20 April 2018
G	Certificate from AFPPS that the bidder is not Blacklisted if not submitted during bid opening	2016 Revised IRR of RA No 9184
H	Certificate of Notarial Commission of the lawyer who notarized the documents submitted by the bidder	2016 Revised IRR of RA No 9184
I	Supporting documents for the Ongoing Government/Private Contracts and the Single Largest Completed Contract:  1. <b>Notice of Award, AND/OR Notice to Proceed, AND/OR Purchase Orders AND/OR Contracts for all Ongoing Contracts as listed per submitted Annex 1;</b>  2. <b>Notice of Award, Notice to Proceed, Purchase Orders OR Contracts relative to Single Largest Completed Contract per submitted Annex 2</b>  3. <b>Certificate of Completion OR Technical Inspection and Acceptance Committee (TIAC) Report OR Official Receipt (duplicate or triplicate copy) OR Sales Invoice with Collection Receipt (duplicate or triplicate copy) OR End-User's Acceptance relative to the Single Largest Completed Contract per submitted Annex 2</b>	2016 Revised IRR of RA No 9184
J	<b>Company Profile</b> (Organization, Affiliated Companies, Production Capability- if applicable)	
K	<b>Vicinity map/location</b> of the business	
<p><b>FOR FOREIGN MANUFACTURER/BIDDER:</b></p> <p>➤ <b>The equivalent to the above-enumerated Class “A” documents issued by country or place of business, in English shall be submitted.</b> If not in English, it must be accompanied by a translation in English, which shall be authenticated by the appropriate Philippine foreign service establishment,</p>		

post, or the equivalent office having jurisdiction over the foreign bidder's affairs in the Philippines. Similar to the required authentication above, for Contracting Parties to the Apostille Convention, all said documents shall be authenticated through an apostille pursuant to GPPB Resolution No. 13-2019 dated 23 May 2019. The English translation shall govern, for purposes of interpretation of the bid; AND

**Note:** *For the Local representative of the foreign bidder: It must likewise submit and present **Registration Certificate** from the Securities and Exchange Commission (SEC), Department of Trade and Industry (DTI) for sole proprietorship, or CDA for cooperatives; and, its Valid and current **Mayor's/Business permit** issued by the local government where the principal place of business of the bidder is located.*

**In case of Joint Venture** (both local and foreign manufacturers), both partners must present/submit the above documents.

## ***Section IV. General Conditions of Contract***

### **1. Scope of Contract**

This Contract shall include all such items, although not specifically mentioned, that can be reasonably inferred as being required for its completion as if such items were expressly mentioned herein. All the provisions of RA No. 9184 and its 2016 revised IRR, including the Generic Procurement Manual, and associated issuances, constitute the primary source for the terms and conditions of the Contract, and thus, applicable in contract implementation. Herein clauses shall serve as the secondary source for the terms and conditions of the Contract.

This is without prejudice to Sections 74.1 and 74.2 of the 2016 revised IRR of RA No. 9184 allowing the GPPB to amend the IRR, which shall be applied to all procurement activities, the advertisement, posting, or invitation of which were issued after the effectivity of the said amendment.

Additional requirements for the completion of this Contract shall be provided in the **Special Conditions of Contract (SCC)**.

### **2. Advance Payment and Terms of Payment**

- 2.1. Advance payment of the contract amount is provided under Annex "D" of the revised 2016 IRR of RA No. 9184.
- 2.2. The Procuring Entity is allowed to determine the terms of payment on the partial or staggered delivery of the Goods procured, provided such partial payment shall correspond to the value of the goods delivered and accepted in accordance with prevailing accounting and auditing rules and regulations. The terms of payment are indicated in the **SCC**.

### **3. Performance Security**

Within ten (10) calendar days from receipt of the Notice of Award by the Bidder from the Procuring Entity but in no case later than prior to the signing of the Contract by both parties, the successful Bidder shall furnish the performance security in any of the forms prescribed in Section 39 of the 2016 revised IRR of RA No. 9184.

### **4. Inspection and Tests**

The Procuring Entity or its representative shall have the right to inspect and/or to test the Goods to confirm their conformity to the specifications at no extra cost to the Procuring Entity in accordance with the Generic Procurement Manual. In addition to tests in the **SCC, Section IV (Technical Specifications)** shall specify what inspections and/or tests the Procuring Entity requires, and where they are to be conducted. The Procuring Entity shall notify the Supplier in writing, in a timely manner, of the identity of any representatives retained for these purposes.

All reasonable facilities and assistance for the inspection and testing of Goods, including access to drawings and production data, shall be provided by the Supplier to the authorized inspectors at no charge to the Procuring Entity.

## **5. Warranty**

- 5.1 In order to assure that manufacturing defects shall be corrected by the Supplier, a warranty shall be required from the Supplier as provided under Section 62.1 of the 2016 revised IRR of RA No. 9184.
- 5.2 The Procuring Entity shall promptly notify the Supplier in writing of any claims arising under this warranty. Upon receipt of such notice, the Supplier shall, repair or replace the defective Goods or parts thereof without cost to the Procuring Entity, pursuant to the Generic Procurement Manual.

## **6. Liability of the Supplier**

The Supplier's liability under this Contract shall be as provided by the laws of the Republic of the Philippines.

If the Supplier is a joint venture, all partners to the joint venture shall be jointly and severally liable to the Procuring Entity.

## *Section V. Special Conditions of Contract*

GCC Clause	
1	<p><b>Delivery and Documents –</b></p> <p>For purposes of the Contract, “EXW,” “FOB,” “FCA,” “CIF,” “CIP,” “DDP” and other trade terms used to describe the obligations of the parties shall have the meanings assigned to them by the current edition of INCOTERMS published by the International Chamber of Commerce, Paris. The Delivery terms of this Contract shall be as follows:</p> <p><i>For Goods supplied from abroad: “The delivery terms applicable to the Contract is DDP delivered at <b>GS Warehouse, 1LSG, Army Support Command, PA, Camp General Servillano Aquino, San Miguel, Tarlac City and GS Warehouse, 2LSG, ASCOM, Camp General Arturo, Malagutay, Zamboanga City</b> in accordance with INCOTERMS.”</i></p> <p><i>For Goods supplied from within the Philippines: “The delivery terms applicable to this Contract is DDP delivered at <b>GS Warehouse, 1LSG, Army Support Command, PA, Camp General Servillano Aquino, San Miguel, Tarlac City and GS Warehouse, 2LSG, ASCOM, Camp General Arturo Enrile, Malagutay, Zamboanga City</b>. Risk and title will pass from the Supplier to the Procuring Entity upon receipt and final acceptance of the Goods at their final destination.”</i></p> <p>Delivery of the Goods shall be made by the Supplier in accordance with the terms specified in Section VI (Schedule of Requirements).</p> <p>For purposes of this Clause the Procuring Entity’s Representative at the Project Site is: <b>PA TIAC, APAO, PA, and G10, PA.</b></p> <p><b>Incidental Services –(if applicable)</b></p> <p>The Supplier is required to provide all of the following services, including additional services, if any, specified in Section VI. Schedule of Requirements:</p> <ol style="list-style-type: none"> <li>a. performance or supervision of on-site assembly and/or start-up of the supplied Goods;</li> <li>b. furnishing of tools required for assembly and/or maintenance of the supplied Goods;</li> <li>c. furnishing of a detailed operations and maintenance manual for each appropriate unit of the supplied Goods;</li> <li>d. performance or supervision or maintenance and/or repair of the supplied Goods, for a period of time agreed by the parties, provided that this service shall not relieve the Supplier of any warranty obligations under this Contract; and</li> </ol>

	<p>e. training of the Procuring Entity’s personnel, at the Supplier’s plant and/or on-site, in assembly, start-up, operation, maintenance, and/or repair of the supplied Goods.</p> <p>The Contract price for the Goods shall include the prices charged by the Supplier for incidental services and shall not exceed the prevailing rates charged to other parties by the Supplier for similar services.</p>
	<p><b>Packaging –(if applicable)</b></p> <p>The Supplier shall provide such packaging of the Goods as is required to prevent their damage or deterioration during transit to their final destination, as indicated in this Contract. The packaging shall be sufficient to withstand, without limitation, rough handling during transit and exposure to extreme temperatures, salt and precipitation during transit, and open storage. Packaging case size and weights shall take into consideration, where appropriate, the remoteness of the Goods’ final destination and the absence of heavy handling facilities at all points in transit.</p> <p>The packaging, marking, and documentation within and outside the packages shall comply strictly with such special requirements as shall be expressly provided for in the Contract, including additional requirements, if any, specified below, and in any subsequent instructions ordered by the Procuring Entity.</p> <p>The outer packaging must be clearly marked as specified in Packaging and Packing of the Technical Specification for this Project.</p>
	<p>A packaging list identifying the contents and quantities of the package is to be placed on an accessible point of the outer packaging if practical. If not practical the packaging list is to be placed inside the outer packaging but outside the secondary packaging.</p> <p><b>Transportation –</b></p> <p>Where the Supplier is required under Contract to deliver the Goods CIF, CIP, or DDP, transport of the Goods to the port of destination or such other named place of destination in the Philippines, as shall be specified in this Contract, shall be arranged and paid for by the Supplier, and the cost thereof shall be included in the Contract Price.</p> <p>Where the Supplier is required under this Contract to transport the Goods to a specified place of destination within the Philippines, defined as the Project Site, transport to such place of destination in the Philippines, including insurance and storage, as shall be specified in this Contract, shall be arranged by the Supplier, and related costs shall be included in the contract price.</p>

	<p>Where the Supplier is required under Contract to deliver the Goods CIF, CIP or DDP, Goods are to be transported on carriers of Philippine registry. In the event that no carrier of Philippine registry is available, Goods may be shipped by a carrier which is not of Philippine registry provided that the Supplier obtains and presents to the Procuring Entity certification to this effect from the nearest Philippine consulate to the port of dispatch. In the event that carriers of Philippine registry are available but their schedule delays the Supplier in its performance of this Contract the period from when the Goods were first ready for shipment and the actual date of shipment the period of delay will be considered force majeure.</p> <p>The Procuring Entity accepts no liability for the damage of Goods during transit other than those prescribed by INCOTERMS for DDP deliveries. In the case of Goods supplied from within the Philippines or supplied by domestic suppliers' risk and title will not be deemed to have passed to the Procuring Entity until their receipt and final acceptance at the final destination.</p> <p><b>Intellectual Property Rights –</b></p> <p>The Supplier shall indemnify the Procuring Entity against all third-party claims of infringement of patent, trademark, or industrial design rights arising from use of the Goods or any part thereof.</p>
2.2	<p>Payment shall be made by <b>Check for local Supplier</b>, or through <b>irrevocable Letter of Credit (LC) in case of foreign supplier/manufacturer</b>.</p> <p>In case payment shall be made by LC, the Procuring Entity shall open the irrevocable LC in favor of the Supplier in accordance with the terms provided below in an Authorized Government Depository Bank after the approval of the Contract by the HOPE and cash transfer from the PA to the Authorized Government Depository Bank, to wit:</p> <ol style="list-style-type: none"> <li>a. Mode of Transmission: Full cable telex/S.W.I.F.T;</li> <li>b. Advising and/or Confirmation: LC may be advised and/or confirmed by any bank to be identified by the Supplier, at the latter's sole expense;</li> <li>c. Payee Bank: The LC draft (if any) shall be drawn on the confirming bank;</li> <li>d. Beneficiary: [Insert name and address of Supplier with Point of Contact];</li> <li>e. Currency and Amount of LC: LC shall be in Philippine Peso, in an amount equivalent to the Total Contract Price. The 95% of the amount of LC shall be released upon completion of all the required documents enumerated in SCC Clause 2.2 (f) of the Bidding Documents and the 5% shall be released upon expiration of the warranty period provided in SCC Clause 5.1 in the Bidding</li> </ol>



	<p>Documents;</p> <p>f. Expiration Date: <b>Two Hundred Ten (210) calendar days</b> from issue date of the L/C;</p> <p>g. The terms of payment shall be as follows: “<b>Partial Payment</b>” to the supplier at the time of <b>partial delivery and final acceptance of the Goods</b> by the Procuring Entity made in accordance with Section VI. Schedule of Requirements, and the submission or presentation of the following documents:</p> <ol style="list-style-type: none"> <li>i. Supplier’s invoice showing Goods’ description, quantity, unit price, and total amount;</li> <li>ii. Negotiable, clean shipped on-board Bill of Lading marked “Freight Pre-Paid” and/or “Non-Negotiable Bill of Lading” or “Airway Bill”;</li> <li>iii. Original Supplier’s factory inspection report or certificate of pre-delivery test and inspection report by PA TIAC (as applicable);</li> <li>iv. Manufacturer’s and/or Supplier’s warranty certificate;</li> <li>v. Certificate of Origin (for imported GOODS);</li> <li>vi. Delivery Receipt detailing number and description of items received signed by the Procuring Entity’s representative at the Delivery Site;</li> <li>vii. Certificate of Acceptance by the PA Technical Inspection and Acceptance Committee (PA TIAC).</li> </ol>
3	<p>If the Performance Security is in the form of a Surety Bond, it must be in the name of the Philippine Army/AFP, and its validity must be until the issuance by the Procuring Entity of the Certificate of Final Acceptance. The Surety Bond must be duly notarized and signed by the Supplier's authorized representative indicating therein his/her full name.</p>
4	<p>The inspections and tests that will be conducted are:</p> <p>a. <b>Post-Qualification</b> involving documents validation, testing and/or manufacturer’s plant visit and inspection shall be conducted by the Procuring Entity or its designated representatives (PQ Team) in order to determine the compliance to the requirements of the end-user as required in the bidding documents. Expenses incurred related hereto particularly travel and board and lodging expenses shall be borne by the Procuring Entity.</p> <p>Submitted prototype/finished samples and swatches duly tested and evaluated as compliant/passed shall be the property and proper disposition of the Procuring Entity while those that were tested and evaluated as non-compliant or Post Disqualified can be retrieved by the Bidder, through an official letter request addressed to PABAC1 (Attn: Chairman, TWG), within three (3) months upon receipt of notice from PABAC1 that such Bidder was Post-Disqualified on said project, otherwise, subject prototype/finished</p>

samples and swatches shall be the property and proper disposition of the Procuring Entity.

All cost related to the testing, including the samples for random testing, shall be for the account of the bidder/supplier.

b. All Items/Goods shall be subjected to **pre-shipment inspection** (PSI) and test by the PA-TIAC. The PSI shall be conducted prior to the expiry of the required delivery period. Appropriate penalties for the delay shall be imposed.

Notes:

1) Supplier/Contractor shall notify the Procuring Entity once the items for delivery/shipment are ready for inspection by the PA-TIAC at the manufacturer's/supplier's facility.

2) The items to be delivered must be complete as specified in Section VI: Schedule of Requirements.

3) All incidental and related expenses relative to inspection particularly travel, board and lodging expenses shall be for the account of the supplier.

4) The PSI shall be conducted in accordance with the prescribed PA Test and Acceptance Procedures.

5) All costs related to the testing, including the samples for random testing, shall be for the account of the bidder/supplier.

6) Item/s subject to destructive testing shall be included during delivery, but shall not be counted as part of the quantity being delivered.

7) In case of dispute/doubts arise on the side of the Supplier from the result of the "Failed" test of their goods, a formal letter may be submitted requesting for a re-test to PAPC within three (3) calendar days (holidays and weekends included) upon receipt of notice that they have failed in the test results.

8) Lapse of the 3-day filing of a request by the Supplier, the TIAC shall promptly issue a **NON-ACCEPTANCE CERTIFICATE** (Attn: PA TIAC) and they will no longer be allowed to deliver the goods at the final destination/delivery site.

9) A re-test (Attn: PA TIAC) to a government-accredited testing facility/center shall be conducted at the expense of the Supplier and the result of which shall be deemed final.

Failed test results from the 1st test or Re-Test shall prompt the TIAC to issue a **NON-ACCEPTANCE CERTIFICATE** (Attn: PA, TIAC) and the Supplier will no longer be allowed to deliver the goods at the final destination/delivery site.

c. **Final Inspection and Acceptance** at the Delivery Site. Completeness and appropriateness of the delivered goods shall be conducted by the Procuring Entity's representative (PATIAC) at the delivery site. Expenses incurred related hereto particularly travel and board and lodging expenses shall be borne by the Procuring Entity.

1) Certificate of Final Acceptance by the TIAC

2) Inspection and Acceptance Report by GS, PAO, PA or its

	<p>FPAO in the delivery site.</p> <p><b>d. Non-Acceptance of Items</b> - In case items are rejected, Philippine Army Technical Inspection and Acceptance Committee (PATIAC) shall issue Certificate of Non-Acceptance on the cause of non-compliance of the item. A corresponding Notice of Non-Acceptance shall then be issued by Philippine Army Procurement Center (PAPC) to the supplier further advising that the period for replacement of defective item is within thirty (30) calendar days from receipt thereof.</p> <p>Once the allowable period of replacement exceeds, the contract shall be terminated. Supplier shall be subjected to blacklisting due to termination for default.</p>
5.1	<p>The warranty shall be covered by, either retention money or a special bank guarantee in favor of the Philippine Army equivalent to five percent (5%) of the Contract Price. The Obligation for the warranty shall only be released after the lapse of the warranty period.</p> <p>The warranty period shall be <b>six (6) months</b> after acceptance by the Procuring Entity of the delivered Goods.</p> <p>The goods to be delivered must have been manufactured <b>not more than six (6) months</b> from the date of delivery.</p>
5.2	<p>The period for correction of defective items in the warranty period is within thirty (30) calendar days upon receipt of notice from the Procuring Entity of any claim arising from the warranty obligation of the supplier. The Procuring Entity through the TIAC may invoke for warranty claims for the Goods or any part thereof that fail to conform to the specifications within the warranty period. The Supplier shall either rectify or replace such defective Goods or parts thereof or make alterations necessary to meet the specifications at no cost to the Procuring Entity, and shall inspect the rectified/replaced goods, at no cost to the Procuring Entity, upon giving a notice pursuant to GCC Clause 5.2</p>
6	<p>If the Supplier fails to satisfactorily deliver any or all of the Goods and/or to perform the Services within the period(s) specified in this Contract inclusive of duly granted time extensions if any, the Procuring Entity shall, without prejudice to its other remedies under this Contract and under the applicable law, deduct from the Contract Price, as liquidated damages, the applicable rate of one tenth (1/10) of one (1) percent of the cost of the unperformed portion for every day of delay until actual delivery or performance. In case the total sum of liquidated damages reaches ten percent (10%) of the total contract price, the Procuring Entity concerned may rescind the contract and impose appropriate sanctions over and above the liquidated damages to be paid</p>

## *Section VI. Schedule of Requirements*

The delivery schedule expressed as weeks/months stipulates hereafter a delivery date which is the date of delivery to the project site.

Description	Quantity	Delivery Period	Delivery Place
Backpack, Tactical, MOLLE, PHILARPAT	7,744 ea	1 <sup>st</sup> Tranche Delivery within <b>Ninety (90)</b> Calendar Days upon Receipt of NTP	GS Warehouse, 1LSG, Army Support Command, PA, Camp General Servillano Aquino, San Miguel, Tarlac City
	2,256 ea		GS Warehouse, 2LSG, Army Support Command, PA, Camp Arturo Enrile, Malagutay, Zamboanga City
	10,366 ea	2 <sup>nd</sup> Tranche Delivery within <b>One Hundred Eighty (180)</b> Calendar Days upon Receipt of NTP	GS Warehouse, 1LSG, Army Support Command, PA, Camp General Servillano Aquino, San Miguel, Tarlac City
	9,000 ea		GS Warehouse, 2LSG, Army Support Command, PA, Camp Arturo Enrile, Malagutay, Zamboanga City
<b>Total</b>	<b>29,366 ea</b>	Full Delivery within <b>One Hundred Eighty (180)</b> Calendar Days upon Receipt of NTP	<b>As stated per Tranche</b>

## Section VII. Technical Specifications

Army Vision: By 2028, a world-class Army that is a source of national pride.

HEADQUARTERS  
PHILIPPINE ARMY  
OFFICE OF THE ARMY QUARTERMASTER  
Fort Andres Bonifacio, Metro Manila

PA SPECIFICATION

QM SPEC NR IE-22BTM  
Amendment - 1  
APR 20 2018  
Interim

### BACKPACK, TACTICAL MOLLE, PHILARPAT

This Amendment forms part of PA QM SPEC NR IE-22BTM dated 10 June 2017 and is mandatory for use of all procuring agencies of the Philippine Army.

1. Page 1, Para 2.2.1 Basic Material – Add the word “Colorless” before the word/s “...coating on the reverse side and conforming to the following requirements.”

2. Page 1, Para 2.2.1 Basic Material – Include the requirement of color quality on PHILARPAT color (beige, black, light green and dark green) and design, to read:

Color Quality (PHILARPAT)<sup>1</sup>  
Color Difference

2.5 (maximum)

  
AURELIO T BADAJOS  
Colonel GSC (QMS) PA  
Chief

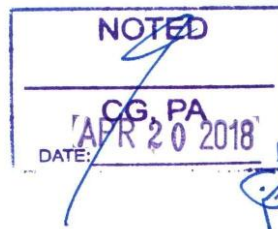

1. The color quality test shall be based on PHILARPAT, BDU color.



*Army Vision: By 2028, a world-class Army that is source of national pride*

HEADQUARTERS  
PHILIPPINE ARMY  
OFFICE OF THE ARMY QUARTERMASTER  
Fort Andres Bonifacio, Metro Manila

PA SPECIFICATION

QM SPEC NR IE-22BTM

*Interim*  
JUN 10 2017

BACKPACK, TACTICAL MOLLE, PHILARPAT

1. SCOPE:

1.1 Scope - This specification covers one (1) type of Backpack, Tactical MOLLE that is extendable and with rain cover for use of military personnel of the Philippine Army in various types of operation. MOLLE stands for Modular Lightweight Load-Carrying Equipment.

1.2 Grade - The finished Backpack shall conform to the quality and grade of product prescribed by this specification.

1.3 Size - There shall be one size for the Backpack and the measurements of the finished Backpack is as shown in the attached illustration.

2. REQUIREMENTS

2.1 First Article - One (1) finished sample of Backpack, Tactical MOLLE shall be submitted to the Office of the Army Quartermaster for first article inspection in accordance with para 3.1.

2.2 Materials

2.2.1 Basic Material - The basic material shall be nylon canvas, PHILARPAT with coating on the reverse side and conforming to the following requirements.

Type of Weave	-	Plain
Thread Count/2.54 cm:		
Warp	-	34 (minimum)
Filling	-	27 (minimum)
Yarn Size, Denier:		
Warp	-	1,350 (minimum)
Filling	-	1,200 (minimum)
Thickness, mm	-	0.60 (minimum)
Weight, g/m	-	400 (maximum)

Page 1 of 22

*Army Core Purpose: Serving the people. Securing the land.*



*Army Vision: By 2028, a world-class Army that is source of national pride*

**PA SPECIFICATION**

**QM SPEC NR IE-22BTM**

**JUN 10 2017**  
**Interim**

Breaking Strength, kg	-	
Warp	-	330 (minimum)
Filling	-	280 (minimum)
Water Repellency, % (Spray Method)	-	80% (minimum)
Water Resistance, grams of water absorbed by blotter	-	0

2.2.2 Lining – The lining shall be made of polyester fabric, olive drab (OD) and shall conform to the following requirements:

Type of Weave	-	Plain
Thread Count/2.54 cm:		
Warp	-	90 (minimum)
Filling	-	65 (minimum)
Yarn Size, Denier:		
Warp	-	85 (minimum)
Filling	-	80 (minimum)
Thickness, mm	-	0.20 (maximum)
Weight, g/m	-	70 (maximum)
Breaking Strength, kg		
Warp	-	40 (minimum)
Filling	-	35 (minimum)

2.2.3 Mesh – The mesh material shall be made of two (2) layered materials. The top and bottom layers are OD, knitted breathable polyester mesh and shall conform to the following requirements:

No. of Holes per 2.54 cm <sup>2</sup>	-	50 (minimum)
Thickness, mm	-	3.0 (maximum)
Weight, g/m <sup>2</sup>	-	250 (maximum)
Bursting Strength, kg/cm <sup>2</sup>	-	18 (minimum)

Page 2 of 22

*Army Core Purpose: Serving the people. Securing the land.*

*Army-vision: By 2028, a world-class Army that is source of national pride*

## PA SPECIFICATION

QM SPEC NR IE-22BTM

JUN 10 2017  
Interim

2.2.4 Straps – All straps shall be made of polyester webbing, olive drab (OD), and shall conform to the following requirements:

Parameters	Strap # 1	Strap # 2	Strap # 3
Width, cm	5.0 ± 0.2	2.5 ± 0.2	2.0 ± 0.2
Thickness, mm	1.0 – 1.5	1.0 – 1.5	1.0 – 1.5
Type of Weave	Plain-Double	Plain-Double	Plain-Double
Breaking Strength, kg	1,000 (minimum)	700 (minimum)	500 (minimum)

2.2.5 Binding Tape - The binding tape shall be made of nylon or polyester webbing, OD and shall conform with the following requirements:

Type of Weave	-	Plain-Double
Width, cm	-	2.0 ± 0.5
Thickness, mm	-	0.7 (minimum)

2.2.6 Padding - The padding material for the shoulder, waist and back/inside of the backpack shall be made of rubberized foam neatly covered with the same material and mesh as specified in para 2.2.1 and 2.2.3, properly shaped and formed as illustrated and shall conform to the following requirements:

Parameters	Padding # 1	Padding # 2
Thickness, mm	10.0 – 11.0	2.5 – 3.5

2.2.7 Elastic Cord – The elastic cord shall be made of nylon or polyester, OD in color with diameter of 3.0 ± 0.5 mm and a minimum breaking strength of 25.0 kg.

2.2.8 Plastic Buckles Accessories – The following plastic buckles accessories shall be made of hard plastic material, Olive Drab in color and shall conform with the following requirements:

Quick Release Buckle (small)	-	7 pieces
Length, cm	-	5.4 ± 0.2
Width, cm	-	2.6 ± 0.2
Thickness, mm	-	11.3 ± 1.0
Breaking Strength, kg	-	45 (minimum)
Quick Release Buckle (medium)	-	2 pieces
Length, cm	-	6.3 ± 0.2
Width, cm	-	3.2 ± 0.2
Thickness, mm	-	12.0 ± 1.0
Breaking Strength, kg	-	45 (minimum)

Page 3 of 22

Army Core Purpose: *Serving the people. Securing the land.*





Army Vision: By 2028, a world-class Army that is source of national pride

## PA SPECIFICATION

## QM SPEC NR IE-22BTM

JUN 10 2017  
Interim

Quick Release Buckle (large)	- 1 piece
Length, cm	- 8.0 ± 0.2
Width, cm	- 6.0 ± 0.2
Thickness, mm	- 15.0 ± 1.0
Breaking Strength, kg	- 100 (minimum)
D-Ring	- 2 pieces
Length, cm	- 3.4 ± 0.2
Width, cm	- 2.8 ± 0.2
Thickness, mm	- 4.0 ± 0.2
Tri-bar Adjustable Buckle (small)	- 3 pieces
Length, cm	- 2.4 ± 0.2
Width, mm <i>cm</i>	- 3.4 ± 0.2
Accommodation width, cm	- 2.9 ± 0.2
Tri-bar Adjustable Buckle (large)	- 1 piece
Length, cm	- 3.2 ± 0.2
Width, cm	- 6.1 ± 0.2
Accommodation width, cm	- 5.2 ± 0.2
Ladder Lock	- 4 pieces
Length, cm	- 4.5 ± 0.2
Width, cm	- 3.4 ± 0.2
Wire Side Adjustable Buckle	- 2 pieces
Length, cm	- 2.8 ± 0.2
Width, cm	- 4.2 ± 0.2
Accommodation width	
Wire Side, cm	- 2.1 ± 0.2
Adjustable Bar, cm	- 2.7 ± 0.2
Bungee Cord Lock	- 1 piece
Length, cm	- 2.8 ± 0.2
Width, cm	- 1.5 ± 0.2

2.2.9 Zipper – The zipper to be used for the main pocket and extension shall be heavy duty nylon No. 8 -10, and No. 4 – 5 for each pocket, olive drab in color and shall be concealed by basic material, olive drab in color.

2.2.10 Thread Sewing – The thread to be used for all stitching shall be made of polyester or nylon Olive Drab in color 2 ply (minimum), and with a breaking strength of not less than 1.5kg.

Page 4 of 22

Army Core Purpose: Serving the people. Securing the land.

*Army Vision: By 2028, a world-class Army that is source of national pride*

## PA SPECIFICATION

QM SPEC NR IE-22BTM

JUN 10 2017

Interim

### 2.3 Construction

2.3.1 Make Body and Bottom – The body and the bottom of backpack shall be cut from the basic material as specified in para 2.2.1, to the correct size and shape giving necessary allowance for hems. The upper body of the backpack shall be provided with two (2) heavy duty nylon zipper, no 8 - 10,  $69.0 \pm 3.0$  cm long for closure and shall be concealed with the basic material  $3.5 \pm 0.2$  cm width. The inside of the backpack shall be provided with padding #2 on one side covered with lining material as specified in para 2.2.2. Join the ends of the fabric and lining material with a binding tape and sewed in a double-lapped seam. The dimension of the backpack is shown on Annex A.

2.3.1.1 The back of the Backpack shall be provided with padding #1 cut on size and shape in accordance to the design in the attached illustration. The padding shall be covered with mesh material as prescribed in para 2.2.3. The padding shall be placed at the back of the backpack and sewn over the basic material to elevate the padding and provide cushioning and ventilation to the back of the user, as illustrated.

2.3.2 Shoulder Strap Padding – The two (2) pieces shoulder strap shall be provided with padding #1 constructed with the material as specified in para 2.2.6 and shall be covered with the basic material on the face side and mesh on the reverse side, as illustrated. The shoulder strap padding shall be connected to the bottom strap (strap #2) with a length of 50 cm (minimum) using a ladder lock adjustable buckle.

2.3.2.1 Modular Strap – Each shoulder strap padding shall have modular straps (strap #2), sewn along the length of each padding and the lower ends of the strap is attached to the ladder lock buckle to connect with the bottom strap as specified in para 2.3.2, while the upper end of the strap is sewn jointly with the shoulder strap padding. Each shoulder strap shall be provided with one (1) tri-bar adjustable buckle, one (1) d-ring and one (1) wire side adjustable buckle place symmetrically on the left and right of the shoulder strap padding. The wire side adjustable buckle shall serve as attachment of the quick release buckle (small) from the horizontal chest strap through a joining loop using strap #3.

2.3.2.2 Shoulder Adjustment/Compression Strap – the shoulder strap padding specified in para 2.3.2 shall be provided with an adjustment strap using strap #2. The lower ends of the strap shall be inserted to the tri-bar adjustable buckle together with the modular strap specified in para 2.3.2.1 and the upper ends of the strap shall be inserted to the ladder lock adjustable buckle that was sewn jointly in the carrying strap #2.

Page 5 of 22

*Army Core Purpose: Serving the people. Securing the land.*

*Army Vision: By 2028, a world-class Army that is source of national pride*

**PA SPECIFICATION****QM SPEC NR IE-22BTM****JUN 10 2017**  
**Interim**

2.3.2.3 Horizontal Chest Strap – The Horizontal Chest strap shall be made of strap #3. The left portion of the chest strap shall have a fixed length of  $4.0 \pm 1.0$  cm, inserted to the wire side adjustable buckle, while the right portion shall be adjustable and shall have a minimum length of 23.0 cm when extended fully while inserted to the other wire side adjustable buckle as illustrated. The left and right portion of the horizontal chest strap shall be attached to the respective wire side adjustable buckle. The female quick release buckle shall be attached to the left portion of the wire side adjustable buckle via strap #3, while the male quick release buckle shall be attached to the right portion of the wire side adjustable buckle via strap #3, as illustrated.

2.3.3 Belt Waist Strap – The belt waist strap is composed of two (2) straps #1,  $50.0 \pm 2.0$  cm long each and sewn at each end of the hip padding  $5.5 \pm 0.5$  cm from the longest edge. The strap is provided with quick release buckle (large) and Tri-bar Adjustable Buckle as specified in 2.2.8. The excess portion of the strap shall firmly be secured with a strap keeper, olive drab in color.

2.3.4 Hip Padding – The hip padding is cut in accordance to size and shape as shown in the attached illustration. It shall cover with the basic material on the face side and mesh material on the reverse/back side. The edges of which are sewn with a binding tape as specified in para 2.2.5.

2.3.5 Carrying Straps – There shall be two (2) carrying straps. Carrying strap #1 is made of strap #1, folded in the middle and sewn at the sides. It is placed and sewn just above the shoulder strap padding. Carrying strap #2 is made of strap #1, placed and sewn at the top of the backpack, as illustrated. It shall double with strap #2 and with bar tacks. The length of carrying strap is shown in Annex A.

2.3.6 Velcro Tape – it shall have a Velcro tape (hook and loop), Olive Drab (OD) in color sewn in the top of the backpack parallel to carrying strap #2, as illustrated. The dimension is  $5.0 \pm 0.5$  cm long and has a width of  $12.0 \pm 0.5$  cm.

2.3.7 Backpack Rain Cover – The backpack cover shall be made of lining material as specified in para 2.2.2 with coating on the reverse side and placed/attached inside the pocket located at the bottom of the backpack enclosed with a no. 4-5 zipper and with a length of  $15.0 \pm 2.0$  cm. The backpack cover shall be attached in a tri-bar adjustable buckle via strap #2, 22.0 cm (minimum) in length for adjustment. The edge of the backpack cover shall have  $2.5 \pm 0.2$  cm width garter, olive drab in color to serve as binding tape and better grip/fit in the backpack when in used. The seam of the backpack cover shall be sewn with a binding tape specified in para 2.2.5.

2.3.8 Extension – The material for the bag extension shall be made of the basic material sewn at the back portion of the backpack and shall be provided with zipper No. 8 – 10 for closure and opening of the backpack extension, as illustrated.

Page 6 of 22

*Army Core Purpose: Serving the people. Securing the land.*



*Army Vision: By 2028, a world-class Army that is source of national pride*

## PA SPECIFICATION

QM SPEC NR IE-22BTM  
JUN 10 2017  
Interim

2.3.9 Utility pouch – The utility pouch shall be made of lining material as specified in para 2.2.2. It shall be placed/attached inside of the  $20.0 \pm 2.0$  cm long slash pocket located between of the two (2) front pockets, as illustrated. The slash pocket shall have a no. 4-5 zipper for opening and closure. The utility pouch shall be provided with two (2) straps #3,  $23.0 \pm 0.5$  cm long sewn both on the lower side of the pouch with quick release buckle (male) that will corresponds in the quick release buckle (female) that are sewn on each of the lower side of the backpack, as illustrated. The opening edge of the utility pouch shall be provided with elastic cord, eyelet and a bungee cord lock for closure. The dimension of the utility pouch is shown in the attach illustration.

2.3.10 Inside Pocket – The inside pocket shall be one-piece made from the lining material specified in para 2.2.2 double thickness with padding #2 in the inside. The height of the pocket is  $32.0 \pm 3.0$  cm and the width shall be measured based on the width and cut of the back of the backpack. It shall be sewed jointly by a binding tape along the edge of the seam on the back of the backpack.

2.3.11 Front Pockets – The two (2) sewn front pockets shall be made of the basic material and provided with two (2) heavy duty nylon zippers, No. 4 - 5 for closure.

2.3.11.1 Front Pockets (small) – two (2) modular straps (strap # 2) are sewn and bar tacked on the front of the pocket. The inside of the pocket shall have a lining and the seam is joined with a binding tape.

2.3.11.2 Front Pockets (big) – Four (4) modular straps (strap # 2) are sewn and bar tacked on the front of the pocket. The inside of the pocket shall have a lining and the seam is joined with a binding tape. The zipper shall be concealed with the basic material.

2.3.12 Side Pockets – The three (3) side pockets shall be made of the basic material and provided with two (2) heavy duty nylon zipper, No. 4 – 5 each for closure and concealed with the basic material. It shall have a lining inside the pocket and the joining seam is sewn with a binding tape. The dimensions of the three pockets are shown in the attach illustration.

2.3.12.1 Side Pocket (small) – Three (3) MOLLE webbing straps (strap #2) are sewn and bar tacked on the front and back of the pocket. There shall be two (2) MOLLE attachment strap (strap #2),  $24.0 \pm 1.0$  cm long, sewn and bar tacked on the back of the pocket. One end of the MOLLE attachment strap shall be folded to serve as lock during attachment of pocket to the MOLLE webbing strap in the side part of the backpack, as illustrated.

Page 7 of 22

*Army Core Purpose: Serving the people. Securing the land.*

*Army Vision: By 2028, a world-class Army that is source of national pride*

**PA SPECIFICATION**

**QM SPEC NR IE-22BTM**  
**JUN 10 2017**  
**Interim**

2.3.12.2 Side Pocket (medium) - Three (3) MOLLE webbing strap (strap #2) are sewn and bar tacked on the front and the back of the pocket. There shall be two (2) MOLLE attachment strap (strap #2), 24.0 ± 1.0 cm long, sewn and bar tacked on the back of the pocket. One end of the MOLLE attachment strap shall be folded to serve as lock during attachment of pocket to the MOLLE webbing strap in the side part of the backpack, as illustrated.

2.3.12.3 Side Pocket (long) - Six (6) MOLLE webbing strap (strap #2) are sewn and bar tacked on the front and the back of the pocket. There shall be four (4) MOLLE attachment strap (strap #2), 24.0 ± 1.0 cm long. The two (2) attachment straps are sewn and bar tacked on the upper portion of the back pocket while the other two (2) attachment straps are sewn and bar tacked on the middle of the back of the pocket. One end of the MOLLE attachment strap shall be folded to serve as lock during attachment of pocket to the MOLLE webbing strap in the side part of the backpack, as illustrated.

2.3.13 Bottom MOLLE webbing Straps – The bottom of the backpack shall be provided with two (2) MOLLE webbing straps (strap #2), 48.0 ± 2.0 cm to serve as reinforcement for the bottom part of the backpack.

2.3.14 Side MOLLE webbing Straps – Each side of the backpack shall be provided with six (6) MOLLE webbing strap for attachment of the pocket, as illustrated.

2.3.15 Quick Release Buckle (small) – there shall be a quick release buckle (small) sewn in the seam on each of the middle front side (both left and right) and upper front side (both left and right) portion of the backpack. It is placed symmetrically on the left and right portion of the backpack, as illustrated. It shall be used as attachment for additional accessories in the backpack.

2.3.16 Compression Strap – the Backpack shall be provided with compression strap by using a quick release buckle (medium). The two (2) compression strap shall be sewn at each side of the backpack align at both ends of the zipper main pocket. It shall be attached by forming a loop and the strap together with the male quick release buckle (medium) will passed through the loop and across the side of the backpack to fasten the male quick release buckle to the female quick release buckle that is sewn at the edge of the back of the backpack, as illustrated. The male and female quick release buckle shall correspond to each other.

2.3.17 Draw Cord – all zippers shall be provided with a draw cord, 23.0 ± 3.0 cm long for easy accessibility.

2.3.18 Strap Keeper – all loose ends or hanging straps shall be provided with a strap keeper, olive drab in color for managing excess webbing straps.

Page 8 of 22  
*Army Core Purpose: Serving the people. Securing the land.*

*Army Vision: By 2028, a world-class Army that is source of national pride*

## PA SPECIFICATION

QM SPEC NR IE-22BTM  
JUN 10 2017  
Interim

2.3.19 Stitches – All sewing and stitching shall be running stitches ranging from 8 – 10 stitches per 2.54 cm.

### 2.4 Workmanship

2.4.1 Design – The Backpack, Tactical MOLLE shall be of the design essentially the same as shown in the attached illustrations.

2.4.2 Manufacturer's Label – Each Backpack, Tactical MOLLE shall have a manufacturer's label printed on the inside upper center of backpack, using black ink or paint. The contents of label shall be as follows:

BACKPACK, TACTICAL MOLLE  
QM SPEC NR IE- 22BTM  
Name of Manufacturer:  
Date Manufactured:

2.4.3 Size of Label – The letters BACKPACK, TACTICAL MOLLE shall be Arial font, size 20 while the rest of the label data shall be Arial font size 12.

2.4.4 "ARMY" Marking - The "ARMY" marking shall be printed on the upper center portion of the front pocket (big) with the use of black ink or paint, Stencil font, Size 150, as illustrated.

2.4.5 Finish – The Backpack, Tactical MOLLE, PHILARPAT shall be clean, well finished and free from any defect which may affect its appearance or serviceability. Overall workmanship shall be the best known to the trade. Poor quality of sewing and workmanship shall be sufficient ground for rejection of the finished article.

## 3. VERIFICATION

3.1 First Article Inspection – The samples of the Backpack, Tactical MOLLE, PHILARPAT submitted in para 2.1 shall be subjected to first article inspection and for approval as against the bid sample. The samples shall be subjected to test and examination to verify if the requirements in para 2.2 through 2.4 are satisfied with reference to the attached test parameters and classification of defects for this document.

### 3.2 Sampling

3.2.1 Samples of materials, component and other items entering into the manufacture of the Backpack, Tactical MOLLE, PHILARPAT shall be taken at random, from time to time by the PA inspectors for the purpose of examination and test to determine compliance with the requirements of this specification.

Page 9 of 22.

*Army Core Purpose: Serving the people, Securing the land.*



Army Vision: By 2028, a world-class Army that is source of national pride

## PA SPECIFICATION

QM SPEC NR JE 22BTM

JUN 10 2017

Interim

3.2.2 Pre-production Sample – Before actual production starts, one (1) finished sample of Backpack, Tactical MOLLE, PHILARPAT shall be submitted to the RDC, ASCOM, PA for verification whether the quality of materials used conform with the requirements of this specification and one (1) finished Backpack, Tactical MOLLE shall be submitted to the Office of the Army Quartermaster for approval as to design, construction, workmanship, style and finish.

## 4. QUALITY ASSURANCE PROVISION

4.1 Responsibility for Inspection – Unless otherwise specified in the contract or purchase order, the contractor is responsible for the performance of all inspection requirements as specified herein. Except as otherwise specified in the contract or purchase order, the contractor may use his own or other facilities suitable for the performance of the inspection requirements specified herein, unless disapproved by the government. The government reserves the right to perform any of the inspections set forth in the specifications which are deemed necessary to assure that supplies and services conform to prescribed requirements.

4.2 Responsibility for Compliance – All items must meet all the requirements of sections 2 and 3. The inspections set forth in this specification shall become a part of the contractor's overall inspection system or quality program. The absence of any inspection requirements in the specification shall not relieve the contractor of the responsibility of assuring that all products or supplies submitted to the Government for acceptance comply with all the requirements of the contract.

4.3 Bid Samples – Two (2) pieces bid samples of the finished Backpack, Tactical MOLLE, PHILARPAT shall be submitted to RDC, ASCOM, PA to determine the extent of compliance with the specification insofar as quality of materials used is concerned. The Office of the Army Quartermaster shall determine the extent of compliance with this specification insofar as workmanship, style and finish are concerned.

## 5. PACKAGING AND PACKING

5.1 Packaging – Each Backpack, Tactical MOLLE, PHILARPAT properly labeled shall be placed in a transparent cellophane bag. The open end of the bag shall be folded and closed with a transparent tape.

Page 10 of 22

Army Core Purpose: *Serving the people. Securing the land.*

*Army Vision: By 2028, a world-class Army that is source of national pride*

**PA SPECIFICATION****QM SPEC NR IE-22BTM****JUN 10 2017**  
**Interim**

5.2 Packing – The Backpack, Tactical MOLLE, PHILARPAT shall be packed in a corrugated carton. The top cover, when closed, shall be sealed with binding tape and finally secured with nylon straps. The box shall be labeled as follows:

BACKPACK, TACTICAL MOLLE

Name of Manufacturer

Date Manufactured:

Quantity:

**6. NOTES**

6.1 The contractor/manufacturer shall notify the Office of the Army Quartermaster at least seven (7) days before actual production starts so that PA inspectors can be assigned to oversee the process of manufacture to be followed and to inspect the quality of materials to be used.

6.2 Any point not covered by this text shall be governed by the attached illustrations which shall be followed in every detail.

  
**AURELIO T. BADAJOS**  
Colonel, QMS (GSC) PA  
Chief

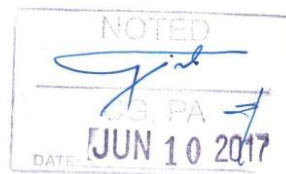



Army Vision: By 2028, a world-class Army that is source of national pride

**PA SPECIFICATION**

QM SPEC NR IE-22BTM  
 JUN 14 2017  
 Interim

**ANNEX "A"**  
**FINISHED SIZES AND MEASUREMENT**  
**BACKPACK, TACTICAL MOLLE**

PARAMETERS	MEASUREMENTS
Height, cm	49.0 ± 5.0
Width, top part, cm	30.0 ± 5.0
Width, bottom part, cm	40.0 ± 5.0
Thickness, side part (excluding the front pocket), cm	17.0 ± 3.0
Thickness, extended part (top portion), cm	7.0 ± 3.0
Thickness, extended part (bottom portion), cm	13.0 ± 3.0
Front Pocket (small) (H-measured at the center x W x T), cm	10.0 ± 1.0 x 22.0 ± 1.0 x 6.0 ± 2.0
Front Pocket (big) (H-measured at the center x W x T), cm	35.0 ± 3.0 x 34.0 ± 3.0 x 9.0 ± 2.0
Side Pocket (small) (H x W x T), cm	18.0 ± 2.0 x 13.0 ± 2.0 x 7.0 ± 2.0
Side Pocket (medium) (H x W x T), cm	22.0 ± 2.0 x 17 ± 2.0 x 7.0 ± 2.0
Side Pocket (long) (H x W x T), cm	44.0 ± 2.0 x 17.0 ± 2.0 x 7.0 ± 2.0
Length of Carrying Strap, cm	
Carrying Strap #1	23.0 ± 3.0
Carrying Strap #2	26.0 ± 2.0

Page 12 of 22  
 Army Core Purpose: Serving the people. Securing the land.

Army Vision: By 2028, a world-class Army that is source of national pride

PA SPECIFICATION

QM SPEC NR IE-22BTM  
JUN 2017  
Interim

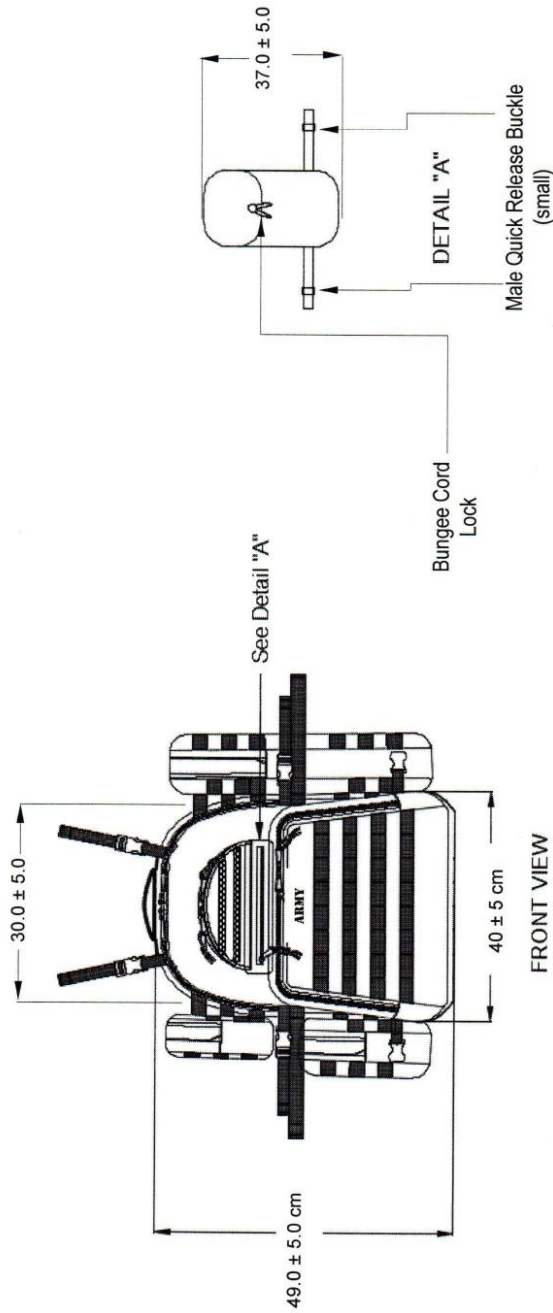

Page 13 of 22  
Army Core Purpose: Serving the people. Securing the land.

Army Vision: By 2028, a world-class Army that is source of national pride

PA SPECIFICATION

QM SPEC NR IE-22BTM  
JUN 10 2017  
Interim

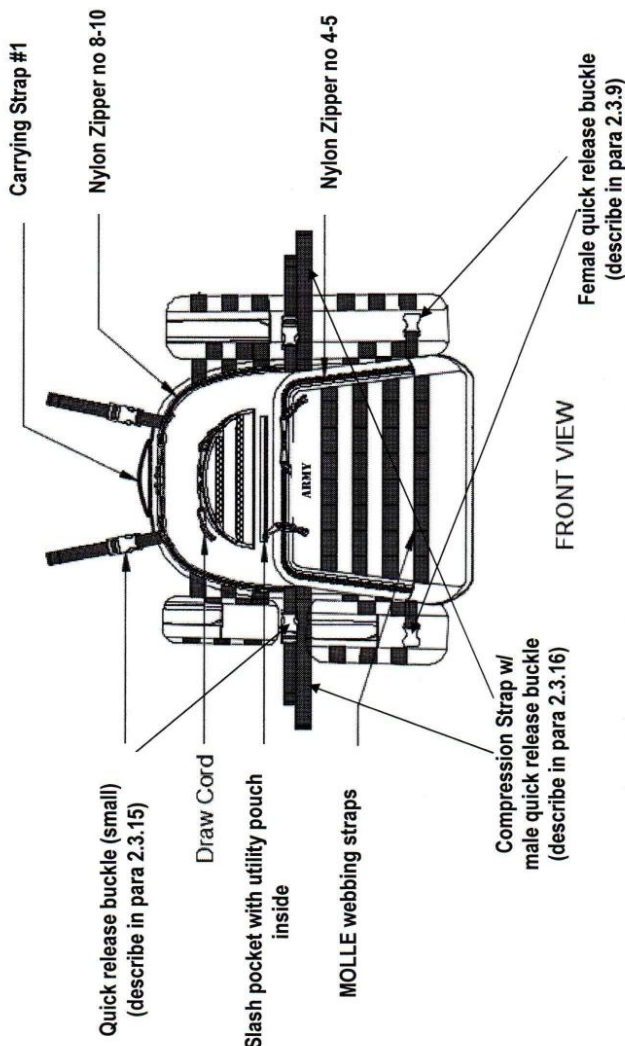

Page 14 of 22  
Army Core Purpose: *Serving the people. Securing the land.*

Army Vision: By 2028, a world-class Army that is source of national pride

PA SPECIFICATION

QM SPEC NR IE-22BTM  
JUN 1, 2017  
Interim

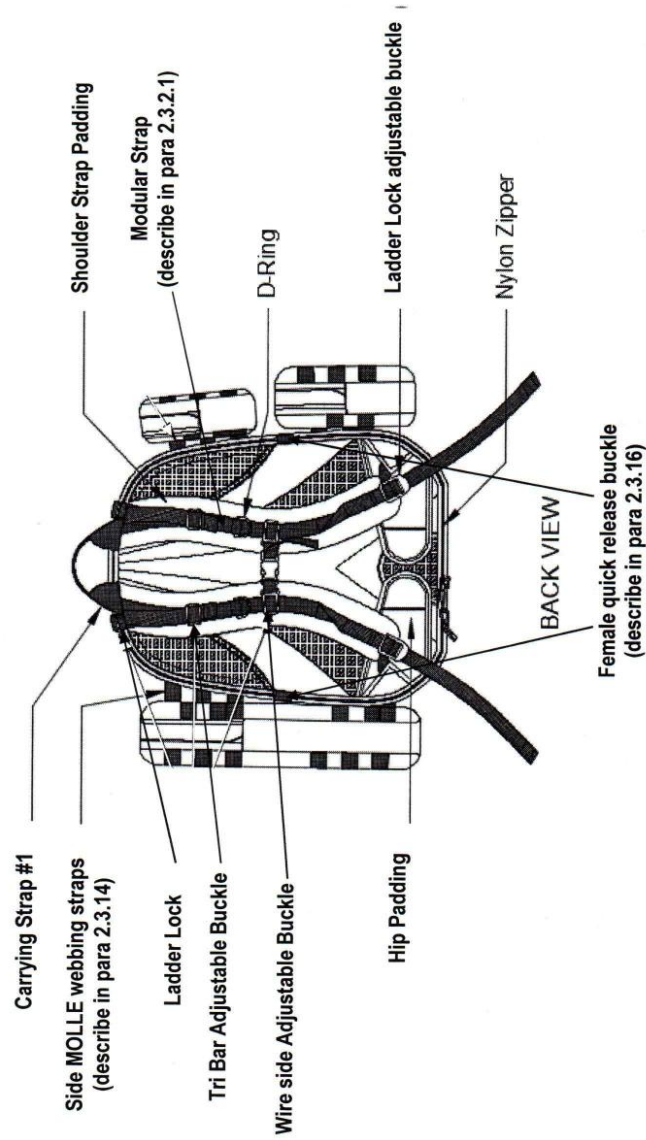

Page 15 of 22  
Army Core Purpose: *Serving the people. Securing the land.*

Army Vision: By 2028, a world-class Army that is source of national pride

PA SPECIFICATION

QM SPEC NR JF-22BTM  
JUN 10 2017  
Interim

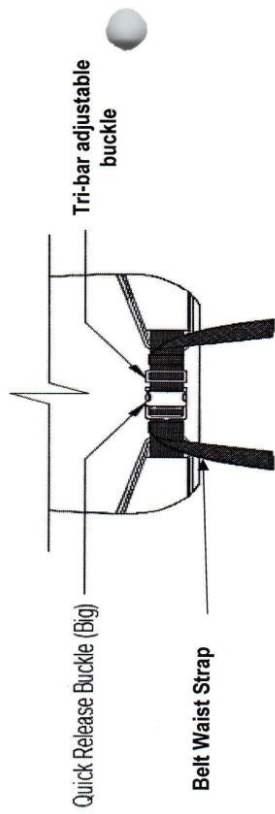

BACK VIEW with BELT WAIST STRAP

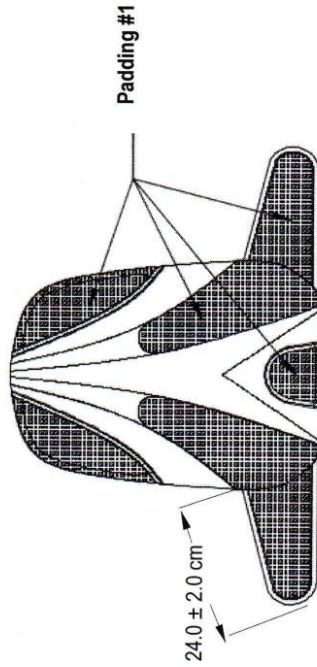

BACK VIEW without SHOULDER STRAP

Page 16 of 22  
Army Core Purpose: Serving the people. Securing the land.

Army Vision: By 2028, a world-class Army that is source of national pride

PA SPECIFICATION

QM SPEC NR IE-22BTM  
JUN 1, 2017  
Interim

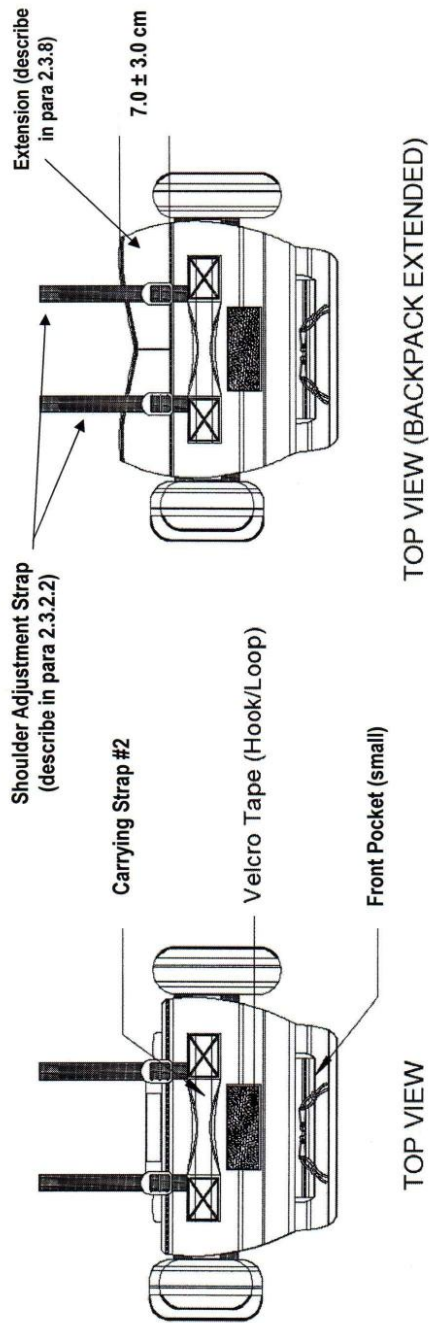

Page 17 of 22  
Army Core Purpose: *Serving the people. Securing the land.*

Army Vision: By 2028, a world-class Army that is source of national pride

PA SPECIFICATION

QM SPEC NR IE-22BTM  
JUN 10 2017  
Interim

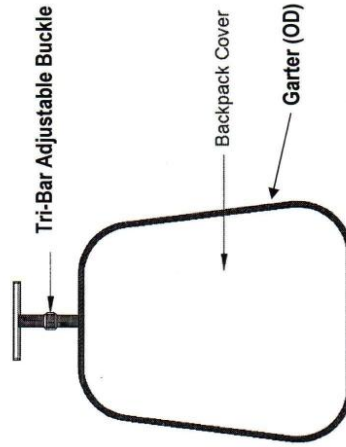
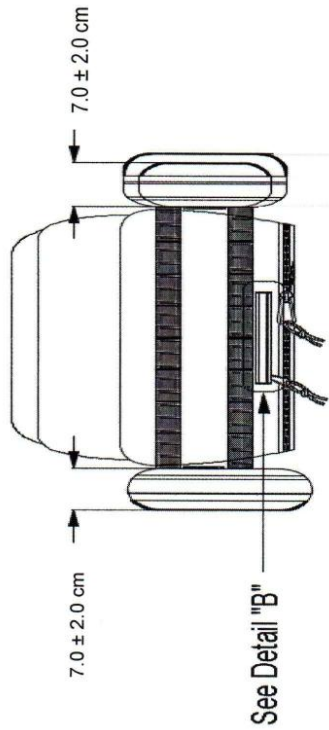

Page 18 of 22  
Army Core Purpose: *Serving the people. Securing the land.*

Army Vision: By 2028, a world-class Army that is source of national pride

PA SPECIFICATION

QM SPEC NR IE-22BTM  
JUN 16 2017  
Interim

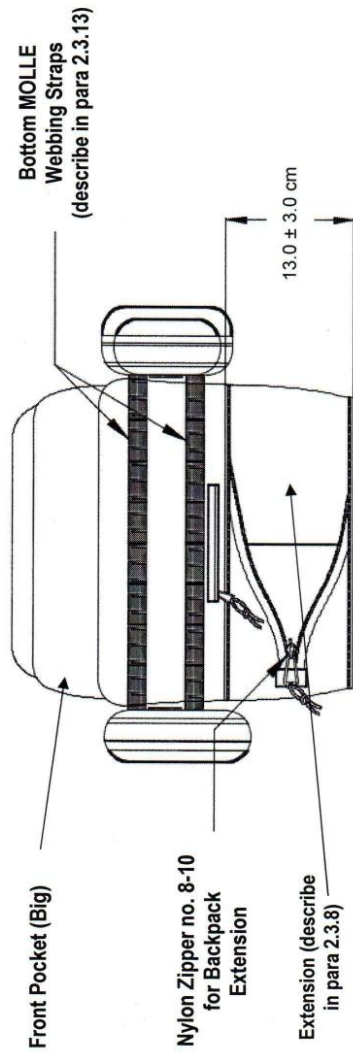

BOTTOM VIEW (BACKPACK EXTENDED)

Page 19 of 22  
Army Core Purpose: *Serving the people. Securing the land.*



Army Vision: By 2028, a world-class Army that is source of national pride

PA SPECIFICATION

QM SPEC NR IE-22BTM  
JUN 14 2017  
Interim

POCKETS

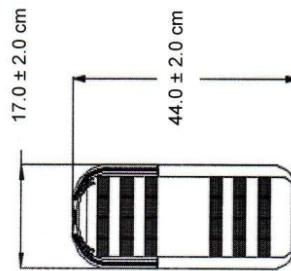
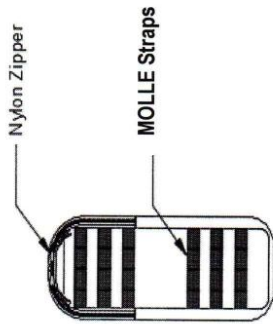

SIDE POCKET (BIG)

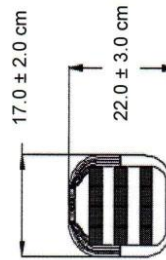
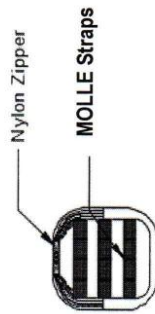

SIDE POCKET (MEDIUM)

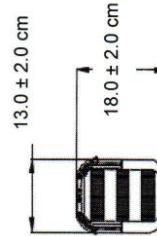
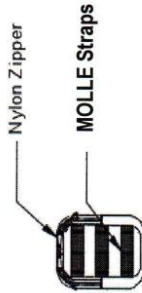

SIDE POCKET (SMALL)

Page 20 of 22

Army Core Purpose: Serving the people. Securing the land.

Army Vision: By 2028, a world-class Army that is source of national pride

**PA SPECIFICATION**

**QM SPEC NR IE-22BTM**  
**JUN 10 2017**  
Interim

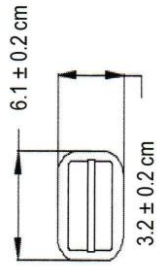

**TRI-BAR ADJUSTABLE BUCKLE (LARGE)**

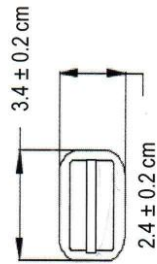

**TRI-BAR ADJUSTABLE BUCKLE (SMALL)**

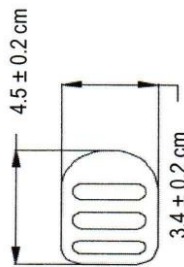

**LADDER LOCK**

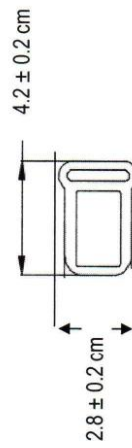

**WIRE SIDE ADJUSTABLE BUCKLE**

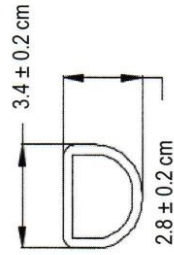

**D - RING**

Page 21 of 22  
Army Core Purpose: *Serving the people. Securing the land.*

Army Vision: By 2028, a world-class Army that is source of national pride

**PA SPECIFICATION**

**QM SPEC NR IE-22BTM**

**Interim**

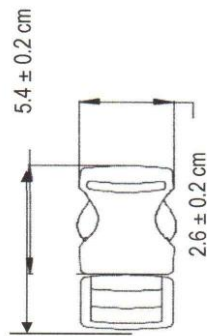

**QUICK RELEASE BUCKLE (SMALL)**

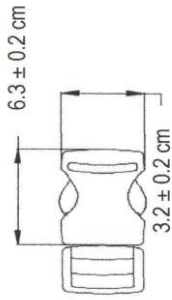

**QUICK RELEASE BUCKLE (MEDIUM)**

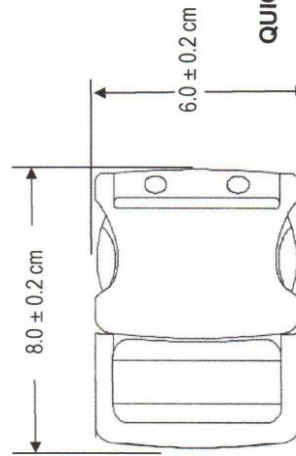

**QUICK RELEASE BUCKLE (LARGE)**

Page 22 of 22  
Army Core Purpose: Serving the people. Securing the land.

By 2018, a world-class Army that is a source of national pride.

HEADQUARTERS  
PHILIPPINE ARMY  
OFFICE OF THE ARMY QUARTERMASTER  
Fort Andres Bonifacio, Metro Manila

**BACKPACK, TACTICAL MOLLE, PHILARPAT**  
QM SPEC NR IE-22BTM dtd 10 June 2017 (Interim)  
With Amendment 1 dated 20 April 2018

**LIST OF REQUIRED SAMPLES AND SWATCH MATERIALS FOR TESTING**

1. **FOR POST QUALIFICATION TEST**

PROTOTYPE SAMPLES

RDC – Two (2) pcs Backpack, Tactical MOLLE  
AQM – One (1) pc Backpack, Tactical MOLLE

SWATCH MATERIALS (Minimum requirements)

Basic Material	-	-	-	-	1m (full width)
Lining	-	-	-	-	1m (full width)
Mesh Material	-	-	-	-	0.5 m x 0.5 m
Straps					
5.0 cm wide	-	-	-	-	1.5 m
2.5 cm wide	-	-	-	-	1.5 m
2.0 cm wide	-	-	-	-	1.5 m
Binding Tape	-	-	-	-	0.5 m
Foam Padding (thickness)					
Padding # 1 (11 mm)	-	-	-	-	10 cm x 10 cm
Padding # 2 (3 mm)	-	-	-	-	10 cm x 10 cm
Elastic Cord	-	-	-	-	1.5 m
Quick Release Buckles	-	-	-	-	3 pcs each sizes
Thread Sewing	-	-	-	-	10 m

2. **FOR ACCEPTANCE TEST**

Three (3) pcs of Backpack, Tactical MOLLE, PHILARPAT – Picked at random from delivery

  
AURELIO T. BADAJOS  
Colonel, QMS (GSC) PA  
Chief



*Honor. Patriotism. Duty.*

## *Section VIII. Checklist of Technical and Financial Documents*

<b>I. TECHNICAL COMPONENT ENVELOPE</b>	
<i>Class "A" Documents</i>	
<u>TAB</u>	<u>Legal Documents</u>
A	Valid and updated PhilGEPS Registration Certificate (Platinum Membership) in accordance with Section 8.5.2 of the revised IRR of RA No. 9184 (updated 19 July 2024) and GPPB Resolution 15 - 2021 dated 14 October 2021.
<u>Technical Documents</u>	
B	<p>Duly signed <b>Statement of the prospective bidder of all its ongoing government and private contracts</b>, including contracts awarded but not yet started, if any, whether similar or not similar in nature and complexity to the contract to be bid.(Annex 1)</p> <p>*The bidder may make a reservation under oath in a notarized document not to disclose the name of its client on the ground of an existing confidentiality agreement but must disclose the amount, status, and name of the project for purposes of validating the NFCC, subject to the full disclosure during post-qualification. In this connection, the bidder may keep the name of the client from the statement of ongoing contracts.</p>
C	<p>Statement of the bidder's <b>Single Largest Completed Contract (SLCC)</b> of similar nature within the last <b>five (5) years</b> from the date of the Receipt and Opening of Bid Envelope.</p> <p>Pursuant to Section 23.4.1.3 of the 2016 revised IRR of RA No.9184, the Bidder shall have an SLCC that is at least one (1) contract similar to the Project the value of which, adjusted to current prices using the PSA's CPI, must be at least equivalent to at least twenty-five percent (25%) of the ABC (Expendable Supplies).</p> <p>* For this project, "<b>similar contract or project</b>" shall pertain to the <b>Supply and Delivery of "any sewn items"</b>.</p>
<u>Financial Documents</u>	
D	<p>The prospective bidder's computation of <b>Net Financial Contracting Capacity (NFCC)(Annex 3-A); <u>or</u></b></p> <p>A <b>Committed Line of Credit</b> from a Universal or Commercial Bank in lieu of its NFCC computation (<b>Annex 3-B</b>).</p> <p>* Should the bidder opt to submit NFCC, computation must be at least equal to the ABC to be bid, calculated as follows.</p> <p>NFCC = [(Current assets minus current liabilities) (15)] minus the value of all ongoing contracts, including awarded contracts yet to be started.</p>

	<p>* The values of the domestic bidder's current assets and current liabilities shall be based on the latest Annual Income Tax Return and Audited Financial Statements filed thru eFPS.</p> <p>* For foreign bidders, the value of the current assets and current liabilities shall be based on their latest Audited Financial Statements (AFS) prepared in accordance with international reporting standards. The NFCC computation shall be expressed in Philippine Peso based on the prevailing exchange rate as published in the BSP reference rate bulletin on the date of preparation of the AFS.</p> <p>* If the prospective bidder opts to submit a Committed Line of Credit, it must be at least equal to ten percent (10%) of the ABC of the project issued by local universal or commercial bank. <b>The amount of Committed Line of Credit must be Machine Validated.</b></p>
<b>Class "B" Documents</b>	
E	<p>Duly signed <b>Joint Venture Agreement (JVA)</b> in case the joint venture is already in existence;<u>or</u></p> <p>In the absence of a JVA, duly <b>Notarized Statement/s from all the potential joint venture partners</b> stating that they will enter into and abide by the provisions of the JVA in the instance that the bid is successful. Failure to enter into a joint venture in the event of a contract award shall be ground for the forfeiture of the bid security; <u>or</u></p> <p>In case JVA is not applicable, the bidder must submit a duly signed <b>Statement stating that JVA is not applicable</b> in lieu of the foregoing(<b>Annex 4</b>).</p> <p>*Note:</p> <ul style="list-style-type: none"> <li>• The JVA should be specific to the project including the purpose and all supporting documents related thereto.</li> </ul>
F	<b>Bid security</b> in the prescribed form, amount and validity period; <u>or</u> a <b>Notarized Bid Securing Declaration(Annex 5)</b> .
G	<p>Conformity with the Schedule of Requirements (<b>Annex 6-A</b>).</p> <p>Duly signed statement of compliance to Technical Specifications (<b>Annex 6-B</b>).</p> <p>Warranty Undertaking (<b>Annex 6-C</b>).</p> <p>Certificate of Replacement for Defective Items(<b>Annex 6-D</b>).</p> <p>Prototype samples and swatch materials required for testing during post-qualification in conformance with the Backpack, Tactical, MOLLE, PHILARPAT with QM SPEC NR IE-22BTM with amendment 1 dated 20 April 2018)</p> <p>*Note: Failure to pay the testing fee within two (2) calendar days from notice (which can be via email, call, or text) shall be tantamount to non-compliance with this requirement and shall be a ground for disqualification.</p>

H	<p><b>Certificate from Armed Forces of the Philippines Procurement Service (AFPPS) that the Bidder is <u>not Blacklisted</u>; <u>or</u></b></p> <p>In the absence of the said Certificate, the Bidder shall submit proof of application of the same stamped received by AFPPS if manually filed, or acknowledged received by the AFPPS through its official email address:afppsthree@gmail.com if electronically filed.</p> <p>*Note:</p> <ul style="list-style-type: none"> <li>• In case of Joint Venture, each JV partner shall submit the Certificate.</li> </ul>
I	Notarized <b>Omnibus Sworn Statement(Annex 7)</b> .
J	<p><b>Proof of Authority of the designated representative/s for purposes of the bidding</b></p> <p><u>For Local Bidder:</u></p> <ol style="list-style-type: none"> <li>a. <b>Duly notarized Special Power of Attorney</b> – For Sole Proprietorship if owner opts to designate a representative/s; OR</li> <li>b. <b>Duly notarized Secretary’s Certificate</b> evidencing the authority of the designated representative/s, issued by the corporation, cooperative or the members of the joint venture.</li> </ol> <p><u>For Foreign Bidder:</u></p> <ol style="list-style-type: none"> <li>a. <b>Valid and Current Written Appointment of the Philippine based company (as local representative of foreign manufacturer) issued by the foreign bidder.</b> The written appointment must include detailed scope of responsibility of the local representative. A Certified True Copy of the Written Appointment may be submitted subject to the presentation of the original document during post qualification; AND</li> <li>b. <b>Duly Notarized authorization of the duly registered Philippine-based company representative</b>(e.g. Secretary’s Certificate for Corporation, Special Power of Attorney for Sole Proprietor) with specimen signature of the authorized representative to transact with PA/AFP including address, telephone number, fax number and email address;</li> </ol> <p>OR</p> <ol style="list-style-type: none"> <li>c. <i>In case the authorized local representative is an individual (citizen of the Philippines), a <b>Valid and Current Written Appointment of the said individual as the local representative issued by the foreign bidder</b> must be submitted.</i> The written appointment must include detailed scope of responsibility of the local representative. A Certified True Copy of the Written Appointment may be submitted subject to the presentation of the original document during post qualification.</li> </ol> <p><i>Note 1 (for both local and foreign bidders): Provided that in the case of</i></p>

*unincorporated joint venture, each member shall submit their respective Special Power of Attorney and/or Secretary's Certificate evidencing the authority of the designated representatives for purposes of this bidding*

*Note 2 (for both local and foreign bidders): The Secretary's Certificate, Board Resolution or Special Power of Attorney, or its equivalent document/proof of authority of the designated representative/s for purposes of the bidding, must have a specimen signature of the bidder or its authorized representative; it must indicate in the said document the authority to transact with the Philippine Army/AFP; it must be specific to the project; and it must indicate in the same document the address, telephone number, mobile phone number, and email address of the bidder or its authorized representative.*

*Note 3 (for both local and foreign bidders): In case of Joint Venture, bidder must submit an Original Special Power of Attorney wherein all members of the Joint Venture are signatories, giving full power and authority to the designated representative of the Joint Venture to sign the OSS and to do acts to represent the bidder.*

## II. FINANCIAL COMPONENT ENVELOPE



---

<u>TAB</u>	<i>Financial Documents</i>
A	Bid Form for the Procurement of Goods( <b>Annex 8-A</b> )
	Duly signed and accomplished Financial Bid Form ( <b>Annex 8-B</b> )
B	Duly signed and accomplished Price Schedule(s) ( <b>Annex 9</b> )

## ***Bidding Forms***

<b>Bidding Forms</b>	<b>Annex Nr</b>
Statement of All On-going Government and Private Contracts including Contracts Awarded but not yet started, if any.	<b>Annex 1</b>
Statement of Single Largest Similar Completed Contract within the last five (5) years from date of submission and receipt of bids equivalent to at least twenty-five (25%) of the ABC	<b>Annex 2</b>
Certificate of Net Financial Contracting Capacity (NFCC)	<b>Annex 3-A</b>
Sample Form for Committed Line of Credit	<b>Annex 3-B</b>
Statement that JVA is not applicable	<b>Annex 4</b>
Bid Securing Declaration	<b>Annex 5</b>
Conformity with the Schedule of Requirements	<b>Annex 6-A</b>
Duly signed statement of compliance to Technical Specifications and Test and Evaluation Procedures	<b>Annex 6-B</b>
Warranty Undertaking	<b>Annex 6-C</b>
Certificate of Replacement for Defective Items	<b>Annex 6-D</b>
Omnibus Sworn Statement	<b>Annex 7</b>
Bid Form for the Procurement of Goods	<b>Annex 8-A</b>
Duly signed and Accomplished Financial Bid Form	<b>Annex 8-B</b>
Bid Prices and applicable Price Schedules	<b>Annex 9</b>

Annex 1

(COMPANY LETTERHEAD)

**Procurement of 29,366 each  
Backpack, Tactical, MOLLE, PHILARPAT  
Bid Ref. No. QM PABAC1 011-25  
Approved Budget Contract: PhP73,415,000.00**

Statement of **All On-going Government and Private Contracts** including Contracts Awarded but not yet started, if any. In case the supplier has no on-going government or private contract, indicate none on the space provided.

1. All On-going Government Contracts

Name of Contract	Date of Contract	Kinds of Goods	Value of Contract	Status of Contract	Date of Delivery	Purchase Order, Notice to Proceed or Contract
<b>TOTAL</b>						

Total Value of Contract: \_\_\_\_\_

2. All On-going Private Contracts

Name of Contract	Date of Contract	Kinds of Goods	Value of Contract	Status of Contract	Date of Delivery	Purchase Order, Notice to Proceed or Contract
<b>TOTAL</b>						

Total Value of Contract: \_\_\_\_\_

CERTIFIED CORRECT:

\_\_\_\_\_  
*Name & Signature of Authorized Representative*

\_\_\_\_\_  
*Position*

\_\_\_\_\_  
*Date*

## Annex 2

## (Company Letterhead)

**Procurement of 29,366 each  
Backpack, Tactical, MOLLE, PHILARPAT  
Bid Ref. No. QM PABAC1 011-25  
Approved Budget Contract: PhP73,415,000.00**

Statement of Single Largest Similar Completed Contract within the last five (5) years from date of submission and receipt of bids equivalent to at least twenty-five (25%) of the ABC

Name of Contract	Date of Contract	Kinds of Goods	Value of Contract	Date of Delivery	End-User's Acceptance or Official Receipts

CERTIFIED CORRECT:

\_\_\_\_\_  
*Name & Signature of Authorized Representative*

\_\_\_\_\_  
*Position*

\_\_\_\_\_  
*Date*

## Annex 3-A

**CERTIFICATE OF NET FINANCIAL CONTRACTING CAPACITY***(Please show figures at how you arrived at the NFCC)*

This is to certify that our **Net Financial Contracting Capacity (NFCC)** is **Philippine Pesos** \_\_\_\_\_ ( P \_\_\_\_\_ ) which is at least equal to the total ceiling price we are bidding.

The amount is computed as follows:  $NFCC = (CA - CL) (K) - C$

Where:

CA = Current Assets

CL = Current Liabilities

K = 15

C = value of all outstanding or uncompleted portions of the projects under ongoing contracts, including awarded contracts yet to be started coinciding with the contract for this Project

Issued this \_\_\_\_\_ day of \_\_\_\_\_, 2024.

CERTIFIED CORRECT:

\_\_\_\_\_  
*Name & Signature of Authorized Representative*

\_\_\_\_\_  
*Position*

\_\_\_\_\_  
*Date*

Annex 3-B

(Name of Bank)  
**COMMITTED LINE OF CREDIT**

Date: \_\_\_\_\_

**ARMED FORCES OF THE PHILIPPINES  
OFFICE OF THE PHILIPPINE ARMY BIDS AND AWARDS COMMITTEE  
Fort Andres Bonifacio, Taguig, City**

PROJECT : \_\_\_\_\_  
 COMPANY/FIRM : \_\_\_\_\_  
 ADDRESS : \_\_\_\_\_  
 BANK/FINANCING INSTITUTION : \_\_\_\_\_  
 ADDRESS : \_\_\_\_\_  
 AMOUNT : \_\_\_\_\_

This is to certify that the above Bank/Financing Institution with business address indicated above, commits to provide the (Supplier/Distributor/Manufacturer), if awarded the above-mentioned Contract, a credit line in the amount specified above which shall be exclusively used to finance the performance of the above-mentioned contract subject to our terms, conditions and requirements.

The credit line shall be available on the date of the submission and opening of bids and such line of credit shall be maintained until the project is completed by the Contractor.

This certification is being issued in favor of said (Supplier/Distributor/Manufacturer) in connection with the bidding requirement of (Name of Procuring Entity) for the above-mentioned Contract. We are aware that any false statements issued by us make us liable for perjury.

The committed line of credit cannot be terminated or cancelled without the prior written approval of the OFFICE OF THE PHILIPPINE ARMY BIDS AND AWARDS COMMITTEE.

\_\_\_\_\_  
Name and Signature of Authorized Financing Institution Office

\_\_\_\_\_  
Official Designation

Concurred By:

\_\_\_\_\_  
Name & Signature of (Supplier/Distributor/Manufacturer's) Authorized Representative

\_\_\_\_\_  
Official Designation

SUBSCRIBED AND SWORN TO BEFORE ME this \_\_\_\_\_ day of \_\_\_\_\_ at \_\_\_\_\_, Philippines. Affiant exhibited to me his/her competent Evidence of identity as defined by the 2004 Rules on Notarial Practice (A.M. No. 02-8-13-SC), issued on \_\_\_\_\_ at \_\_\_\_\_.

NOTARY PUBLIC

Doc No: \_\_\_\_\_  
Page No: \_\_\_\_\_  
Book No: \_\_\_\_\_  
Series of: \_\_\_\_\_

## Annex 4

(Company Letterhead)

**Procurement of 29,366 each  
Backpack, Tactical, MOLLE, PHILARPAT  
Bid Ref. No. QM PABAC1 011-25  
Approved Budget Contract: PhP73,415,000.00**

This is to certify that \_\_\_\_\_ (name of bidder) \_\_\_\_\_ will be participating **without a joint venture partner** in the procurement of \_\_\_\_\_ (name of project) \_\_\_\_\_.

Further, the undersigned acknowledges that **Joint Venture Agreement is Not Applicable** for the above-mentioned project.

CERTIFIED CORRECT:

\_\_\_\_\_  
*Name & Signature of Authorized Representative*

\_\_\_\_\_  
*Position*

\_\_\_\_\_  
*Date*



## Annex 5

Name of Project: \_\_\_\_\_  
 Public Bidding Nr: \_\_\_\_\_  
 ABC: \_\_\_\_\_

**BID-SECURING DECLARATION**

REPUBLIC OF THE PHILIPPINES)  
 CITY OF .....

**BID-SECURING DECLARATION**

Invitation to Bid/Request for Expression of Interest No. 1: (Insert reference number)

To: (Insert name and address of the Procuring Entity)

I/We, the undersigned, declare that:

1. I/We understand that, according to your conditions, bids must be supported by a Bid Security, which may be in the form of a Bid-Securing Declaration.
2. I/We accept that: (a) I/We will be automatically disqualified from bidding for any contract with any procuring entity for a period of two (2) years upon receipt of your Blacklisting Order; and (b) I/We will pay the applicable fine provided under Section 6 of the Guidelines on the Use of Bid Securing Declarations, within fifteen (15) days from receipt of the written demand by the procuring entity for the commission of acts resulting to the enforcement of the bid securing declaration under Sections 23.1 (b), 34.2, 40.1 and 69.1, except 69.1 (f) of the IRR of RA 9184; without prejudice to other legal action the government may undertake.
3. I/We understand that this Bid-Securing Declaration shall cease to be valid on the following circumstances:
  - a) Upon expiration of the bid validity period, or any extension thereof pursuant to your request;
  - b) I am/we are declared ineligible or post-disqualified upon receipt of your notice to such effect, and (i) I/We failed to timely file a request for consideration or (ii) I/We filed a waiver to avail of said right;
  - c) I am/were declared as the bidder with the Lowest Calculated and Responsive Bid/Highest Rated and Responsive Bids, and I/We have furnished the performance security and signed the Contract.

IN WITNESS WHEREOF, I/We hereunto set my/our hand/s this \_\_\_\_\_ day of (Month) (Year) at (Place of Execution).

NAME OF BIDDERS AUTHORIZED REPRESENTATIVE

(Insert signatory's legal capacity)

**AFFIANT**

SUBSCRIBED AND SWORN TO BEFORE ME this \_\_\_\_\_ day of \_\_\_\_\_ at \_\_\_\_\_, Philippines. Affiant exhibited to me his/her competent Evidence of identity as defined by the 2004 Rules on Notarial Practice (A.M. No. 02-8-13-SC), issued on \_\_\_\_\_ at \_\_\_\_\_.

NOTARY PUBLIC

Doc No: \_\_\_\_\_  
Page No: \_\_\_\_\_  
Book No: \_\_\_\_\_  
Series of: \_\_\_\_\_

## Annex 6-A

**SCHEDULE OF REQUIREMENTS**

**Procurement of 29,366 each  
Backpack, Tactical, MOLLE, PHILARPAT  
Bid Ref. No. QM PABAC1 011-25  
Approved Budget Contract: PhP73,415,000.00**

TO THE BIDDER: Indicate “COMPLY” If proposal meets the technical specifications and project requirements. <b>DO NOT LEAVE ANY BLANK. A “YES OR NO” ENTRY WILL NOT BE ACCEPTED. FAILURE TO CONFORM WILL RESULT IN A RATING OF “FAILED”.</b>				
Description	Qty/Unit	Full Delivery within;	Delivery Place	Bidders Proposal
Backpack, Tactical, MOLLE, PHILARPAT	7,744 ea	1 <sup>st</sup> Tranche Delivery within <b>Ninety (90)</b> Calendar Days upon Receipt of NTP	GS Warehouse, 1LSG, Army Support Command, PA, Camp General Servillano Aquino, San Miguel, Tarlac City	
	2,256 ea		GS Warehouse, 2LSG, Army Support Command, PA, Camp Arturo Enrile, Malagutay, Zamboanga City	
	10,366 ea	2 <sup>nd</sup> Tranche Delivery within <b>One Hundred Eighty (180)</b> Calendar Days upon Receipt of NTP	GS Warehouse, 1LSG, Army Support Command, PA, Camp General Servillano Aquino, San Miguel, Tarlac City	
	9,000 ea		GS Warehouse, 2LSG, Army Support Command, PA, Camp Arturo Enrile, Malagutay, Zamboanga City	
Total	29,366 ea	Full Delivery within <b>One Hundred Eighty (180)</b> Calendar Days upon Receipt of NTP	As stated per Tranche	

CERTIFIED CORRECT:

\_\_\_\_\_  
*Name & Signature of Authorized Representative*

\_\_\_\_\_  
*Position*

*Date*

**Annex 6-B**

**COMPLIANCE TO TECHNICAL SPECIFICATION**

**Procurement of 29,366 each  
Backpack, Tactical, MOLLE, PHILARPAT  
Bid Ref. No. QM PABAC1 011-25  
Approved Budget Contract: PhP73,415,000.00**

TO THE BIDDER: Indicate “**COMPLY**” If proposal meets the technical specifications and project requirements. **DO NOT LEAVE ANY BLANK. A “YES OR NO” ENTRY WILL NOT BE ACCEPTED. FAILURE TO CONFORM WILL RESULT IN A RATING OF “FAILED”.**

Quantity/Item Description	Required Technical Specifications/Test Parameters	Bidder's Proposal
Backpack, Tactical, MOLLE, PHILARPAT	<b>QM SPEC NR IE-22BTM with amendment 1 dated 20 April 2018</b>	

I/WE, the undersigned bidder, have examined the Bidding Documents including Bid Bulletins, as applicable, hereby OFFER to (supply/deliver/perform) the above-described items.

I/WE undertake, if our bid is accepted, to deliver the items in accordance with the terms and conditions contained in the bid documents, including the posting of the required performance security **within ten (10) calendar days** from receipt of the Notice of Award.

Until a formal contract/order confirmation is prepared and signed, this Bid is binding on us.

\_\_\_\_\_  
Name of Company

\_\_\_\_\_  
Signature of Company Representative

\_\_\_\_\_  
Name & Designation

\_\_\_\_\_  
Date

## Annex 6-C

(Bidder's Company Letterhead)

## WARRANTY UNDERTAKING

**Procurement of 29,366 each  
Backpack, Tactical, MOLLE, PHILARPAT  
Bid Ref. No. QM PABAC1 011-25  
Approved Budget Contract: PhP73,415,000.00**

I/We, \_\_\_\_\_ (Name) \_\_\_\_\_ (Title/Capacity) \_\_\_\_\_, the duly authorized representative of (Company/Bidder) \_\_\_\_\_, hereby commits that should we be awarded the contract, we will issue a Warranty Certificate in favor of the Philippine Army (PA) valid for **six (6) months** from date of final acceptance.

This Undertaking shall form part of the Technical Requirements for the aforesaid procurement project

\_\_\_\_\_  
Signature of Company Representative

\_\_\_\_\_  
Name & Designation

\_\_\_\_\_  
Date

Annex 6-D

(Bidder's Company Letterhead)

**CERTIFICATE OF REPLACEMENT FOR DEFECTIVE  
ITEMS**

**Procurement of 29,366 each  
Backpack, Tactical, MOLLE, PHILARPAT  
Bid Ref. No. QM PABAC1 011-25  
Approved Budget Contract: PhP73,415,000.00**

I/We, \_\_\_\_\_ (Name) \_\_\_\_\_, \_\_\_\_\_ (Title/Capacity) \_\_\_\_\_, the duly authorized representative of (Company/Bidder) \_\_\_\_\_, hereby commits that should we be awarded the contract, we will replace all defective items **within thirty (30) calendar days** upon receipt of Notice of Defects from the Philippine Army.

Supplier further certifies that the goods to be delivered have been manufactured **not more than one (1) year** from the date of delivery.

This Certification shall form part of the Technical Requirements for the aforesaid procurement project.

Issued this \_\_\_\_\_ day of \_\_\_\_\_ 2024 in \_\_\_\_\_, Philippines

\_\_\_\_\_  
Name of Company (Bidder)

\_\_\_\_\_  
Full Name of Authorized Representative

\_\_\_\_\_  
Address

\_\_\_\_\_  
Signature of Authorized Representative

\_\_\_\_\_  
Tel. No./Fax

\_\_\_\_\_  
E-mail Address

## Annex 7

**Omnibus Sworn Statement (Revised)***[shall be submitted with the Bid]*

REPUBLIC OF THE PHILIPPINES )  
 CITY/MUNICIPALITY OF \_\_\_\_\_ ) S.S.

**AFFIDAVIT**

I, [Name of Affiant], of legal age, [Civil Status], [Nationality], and residing at [Address of Affiant], after having been duly sworn in accordance with law, do hereby depose and state that:

1. *[Select one, delete the other:]*

*[If a sole proprietorship:]* I am the sole proprietor or authorized representative of [Name of Bidder] with office address at [address of Bidder];

*[If a partnership, corporation, cooperative, or joint venture:]* I am the duly authorized and designated representative of [Name of Bidder] with office address at [address of Bidder];

2. *[Select one, delete the other:]*

*[If a sole proprietorship:]* As the owner and sole proprietor, or authorized representative of [Name of Bidder], I have full power and authority to do, execute and perform any and all acts necessary to participate, submit the bid, and to sign and execute the ensuing contract for [Name of the Project] of the [Name of the Procuring Entity], as shown in the attached duly notarized Special Power of Attorney;

*[If a partnership, corporation, cooperative, or joint venture:]* I am granted full power and authority to do, execute and perform any and all acts necessary to participate, submit the bid, and to sign and execute the ensuing contract for [Name of the Project] of the [Name of the Procuring Entity], as shown in the attached [state title of attached document showing proof of authorization (e.g., duly notarized Secretary's Certificate, Board/Partnership Resolution, or Special Power of Attorney, whichever is applicable)];

3. [Name of Bidder] is not "blacklisted" or barred from bidding by the Government of the Philippines or any of its agencies, offices, corporations, or Local Government Units, foreign government/foreign or international financing institution whose blacklisting rules have been recognized by the Government Procurement Policy Board, **by itself or by relation, membership, association, affiliation, or controlling interest with another blacklisted person or entity as defined and provided for in the Uniform Guidelines on Blacklisting;**

4. Each of the documents submitted in satisfaction of the bidding requirements is an authentic copy of the original, complete, and all statements and information provided therein are true and correct;

5. [Name of Bidder] is authorizing the Head of the Procuring Entity or its duly authorized representative(s) to verify all the documents submitted;
6. *[Select one, delete the rest:]*

*[If a sole proprietorship:]* The owner or sole proprietor is not related to the Head of the Procuring Entity, members of the Bids and Awards Committee (BAC), the Technical Working Group, and the BAC Secretariat, the head of the Project Management Office or the end-user unit, and the project consultants by consanguinity or affinity up to the third civil degree;

*[If a partnership or cooperative:]* None of the officers and members of *[Name of Bidder]* is related to the Head of the Procuring Entity, members of the Bids and Awards Committee (BAC), the Technical Working Group, and the BAC Secretariat, the head of the Project Management Office or the end-user unit, and the project consultants by consanguinity or affinity up to the third civil degree;

*[If a corporation or joint venture:]* None of the officers, directors, and controlling stockholders of *[Name of Bidder]* is related to the Head of the Procuring Entity, members of the Bids and Awards Committee (BAC), the Technical Working Group, and the BAC Secretariat, the head of the Project Management Office or the end-user unit, and the project consultants by consanguinity or affinity up to the third civil degree;

7. *[Name of Bidder]* complies with existing labor laws and standards; and
8. *[Name of Bidder]* is aware of and has undertaken the responsibilities as a Bidder in compliance with the Philippine Bidding Documents, which includes:
  - a. Carefully examining all of the Bidding Documents;
  - b. Acknowledging all conditions, local or otherwise, affecting the implementation of the Contract;
  - c. Making an estimate of the facilities available and needed for the contract to be bid, if any; and
  - d. Inquiring or securing Supplemental/Bid Bulletin(s) issued for the *[Name of the Project]*.
9. *[Name of Bidder]* did not give or pay directly or indirectly, any commission, amount, fee, or any form of consideration, pecuniary or otherwise, to any person or official, personnel or representative of the government in relation to any procurement project or activity.

10. **In case advance payment was made or given, failure to perform or deliver any of the obligations and undertakings in the contract shall be sufficient grounds to constitute criminal liability for Swindling (Estafa) or the commission of fraud with unfaithfulness or abuse of confidence through misappropriating or converting any payment received by a person or entity under an obligation involving the duty to deliver certain goods or services, to the prejudice of the public and the government of the Philippines pursuant to Article 315 of Act No. 3815 s. 1930, as amended, or the Revised Penal Code.**



IN WITNESS WHEREOF, I have hereunto set my hand this \_\_\_ day of \_\_\_, 20\_\_\_  
at \_\_\_\_\_, Philippines.

\_\_\_\_\_  
Bidder's Representative/Authorized Signatory  
*[Insert signatory's legal capacity]*  
Affiant

**[Jurat]**

*[Format shall be based on the latest Rules on Notarial Practice]*

SUBSCRIBED AND SWORN TO BEFORE ME this \_\_\_\_\_ day of  
\_\_\_\_\_ at \_\_\_\_\_, Philippines. Affiant exhibited to me his/her competent Evidence of  
identity as defined by the 2004 Rules on Notarial Practice (A.M. No. 02-8-13-SC), issued on  
\_\_\_\_\_ at \_\_\_\_\_.

NOTARY PUBLIC

Doc No: \_\_\_\_\_  
Page No: \_\_\_\_\_  
Book No: \_\_\_\_\_  
Series of: \_\_\_\_\_

## Annex 8-A

**Bid Form for the Procurement of Goods**  
*[shall be submitted with the Bid]*

**BID FORM**

Date: \_\_\_\_\_

Project Identification No.: \_\_\_\_\_

To: *[name and address of Procuring Entity]*

Having examined the Philippine Bidding Documents (PBDs) including the Supplemental or Bid Bulletin Numbers *[insert numbers]*, the receipt of which is hereby duly acknowledged, we, the undersigned, offer to *[supply/deliver/perform]* *[description of the Goods]* in conformity with the said PBDs for the sum of *[total Bid amount in words and figures]* or the total calculated bid price, as evaluated and corrected for computational errors, and other bid modifications in accordance with the Price Schedules attached herewith and made part of this Bid. The total bid price includes the cost of all taxes, such as, but not limited to: *[specify the applicable taxes, e.g. (i) value added tax (VAT), (ii) income tax, (iii) local taxes, and (iv) other fiscal levies and duties]*, which are itemized herein or in the Price Schedules, If our Bid is accepted, we undertake:

- a. to deliver the goods in accordance with the delivery schedule specified in the Schedule of Requirements of the Philippine Bidding Documents (PBDs);
- b. to provide a performance security in the form, amounts, and within the times prescribed in the PBDs;
- c. to abide by the Bid Validity Period specified in the PBDs and it shall remain binding upon us at any time before the expiration of that period.

*[Insert this paragraph if Foreign-Assisted Project with the Development Partner:*

Commissions or gratuities, if any, paid or to be paid by us to agents relating to this Bid, and to contract execution if we are awarded the contract, are listed below:

Name and address of agent	Amount	Purpose
_____	_____	_____
_____	_____	_____
_____	_____	_____

(if none, state "None") ]

Until a formal Contract is prepared and executed, this Bid, together with your written acceptance thereof and your Notice of Award, shall be binding upon us.

We understand that you are not bound to accept the Lowest Calculated Bid or any Bid you may receive.

We certify/confirm that we comply with the eligibility requirements pursuant to the

PBDs.

The undersigned is authorized to submit the bid on behalf of *[name of the bidder]* as evidenced by the attached *[state the written authority]*.

We acknowledge that failure to sign each and every page of this Bid Form, including the attached Schedule of Prices, shall be a ground for the rejection of our bid.

Name: \_\_\_\_\_ Legal capacity: \_\_\_\_\_ Signature: \_\_\_\_\_  
Duly authorized to sign the Bid for and behalf of: \_\_\_\_\_ Date: \_\_\_\_\_

## Annex 8-B

**(Bidder's Company Letterhead)**

**Procurement of 29,366 each  
Backpack, Tactical, MOLLE, PHILARPAT  
Bid Ref. No. QM PABAC1 011-25  
Approved Budget Contract: PhP73,415,000.00**

**FINANCIAL BID FORM**

Description	Qty	ABC Price		Bidder's Proposal	
		U/P	Total Price	U/P	Total Price
Backpack, Tactical, MOLLE, PHILARPAT	29,366 each	PhP2,500.00	PhP73,415,000.00		
<b>TOTAL BID PRICE</b>					
<b>Total Bid Price (Amount in Words):</b>					
<b>BIDDER'S UNDERTAKING</b>					
I/We, the undersigned bidder, having examined the Bidding Documents including Bid Bulletins, as applicable, hereby OFFER to (supply/deliver/perform) the above-described items.					
I/We undertake, if our bid is accepted, to deliver the items in accordance with the terms and conditions contained in the bid documents, including the posting of the required performance security within ten (10) calendar days from receipt of Notice of Award.					
Until a formal contract/order confirmation is prepared and signed, this Bid is binding on us.					

\_\_\_\_\_  
Name of Company (in print)

\_\_\_\_\_  
Signature of Company Representative

\_\_\_\_\_  
Name & Designation (in print)

\_\_\_\_\_  
Date

**Annex 9  
FORM NO. 1**

**(Bidder’s Company Letterhead)**

**Procurement of 29,366 each  
Backpack, Tactical, MOLLE, PHILARPAT  
Bid Ref. No. QM PABAC1 011-25  
Approved Budget Contract: PhP73,415,000.00**

**For Goods Offered From Abroad**

Name of Bidder \_\_\_\_\_ . Invitation to Bid<sup>1</sup> Number \_\_\_\_ . Page \_\_\_\_ of \_\_\_\_\_ .

1	2	3	4	5	6	7	8	9
Item	Description	Country of origin	Qty	Unit price CIF port of entry (specify port) or CIP named place (specify border point or place of destination)	Total CIF or CIP price per item (col. 4 x 5)	Unit Price Delivered at Place (DAP)	Unit price Delivered Duty Paid (DDP)	Total Price -(if DAP col 4X7) -(If DDP col 4X8)

Note: If the particular column is not applicable indicate **dash (-)** or **zero (0)**, as applicable.

\_\_\_\_\_ *[signature]*

\_\_\_\_\_ *[in the capacity of]*

Duly authorized to sign Bid for and

<sup>1</sup> If ADB, JICA and WB funded projects, use IFB.

**Annex 9  
FORM NO. 2**

**(Bidder's Company Letterhead)**

**Procurement of 29,366 each  
Backpack, Tactical, MOLLE, PHILARPAT  
Bid Ref. No. QM PABAC1 011-25  
Approved Budget Contract: PhP73,415,000.00**

**For Goods Offered From Within the Philippines**

Name of Bidder \_\_\_\_\_ Invitation to Bid<sup>2</sup> Number \_ Page \_ of \_\_\_\_.

1	2	3	4	5	6	7	8	9	10
Item	Description	Country of origin	Quantity	Unit price EXW per item	Transportation and Insurance and all other costs incidental to delivery, per item	Sales and other taxes payable if Contract is awarded, per item	Cost of Incidental Services, if applicable, per item	Total Price, per unit (col 5+6+7+8)	Total Price delivered Final Destination (col 9) x (col 4)

Note: If the particular column is not applicable indicate **dash (-)** or **zero (0)**, as applicable.

\_\_\_\_\_ *[signature]*

\_\_\_\_\_ *[in the capacity of]*

Duly authorized to sign Bid for and on behalf of \_\_\_\_\_

<sup>2</sup> If ADB, JICA and WB funded projects, use IFB.

